

An-Najah National University

Faculty of Engineering and

Information Technology

Project Name:

Public Smart Library in the City of Nablus

Prepared By: Reham

Braik

Supervisor:

Dr. Sameh Monna

This Thesis is Submitted in Partial Fulfillment of the Requirements for the Degree of Bachelors of Engineering Architectural, Faculty of Engineering and Information Technology, An-Najah National University, Nablus, Palestine.

2022

الإقرار

-----رهام بريك-----

أنا الموقع أدناه، مقدم الرسالة التي تحمل العنوان:

أقر بأن ما شملته هذه الرسالة إنما هو نتاج جهدي الخاص، باستثناء ما تمت الإشارة إليه حيثما ورد، وأن هذه الرسالة ككل، أو أي جزء منها لم يقدم من قبل لنيل أي درجة أو لقب علمي لدى أي مؤسسة تعليمية أو بحثية أخرى.

Declaration

The work provided in this thesis, unless otherwise referenced, is the researcher's own work, and has not been submitted elsewhere for any other degree or qualification.

Student's Name:

Reham Braik

Signature:

RehamBraik

Date:

12/7/2023

Abstract

Human knowledge has been accumulating over history. With the rapid increase in the amount of information and advancement of civilization in the world, libraries initially appeared as places to keep and record this accumulated knowledge. Today, Libraries are source of books, places to read, socialize, gather, learn, and access to knowledge.

In this chapter,

They are a significant place to acquire, organize, preserve the accumulated knowledge and disseminate it to whomever needs them. Libraries also provide people with opportunities to communicate, interact, learn and socialize. They play a significant role in shaping the identity and culture of any society.

Libraries are an object that grows with the growth of the times, so we see the chronology of the forms of libraries and their keeping up with every scientific discovery. We now see the development that our libraries have reached on the social, cultural, educational and entertainment levels and related to research and access to knowledge. We see the expansion of spaces and the introduction of new jobs and smart services that help individuals without the need To put a lot of effort into getting what they need. Libraries today have become smart with the intelligence of the technologies available today in the technological sector, and we can say that what we have in our hands today is digital libraries, which have taken a large space in our

libraries today.

Table of Contents

ABSTRACT	I
CHAPTER 1 INTRODUCTION	1
1.1 THE ESTABLISHMENT OF LIBRARIES	1
1.1.1 Definition of Library.....	1
1.1.2 Historical Development of Libraries.....	2
1.2 TYPES OF LIBRARIES:	6
1.2.1 Public Library	6
1.2.2 National Library.....	7
1.2.3 School Library	7
1.2.4 Academic Library	8
1.2.5 Specialized library	8
1.2.6 Children’s library	8
1.2.7 Mobile library	8
1.2.8 Smart library	9
1.3 SMART LIBRARY	9
1.3.1 Definition of Smart library.....	9
1.3.2 Technologies for smart library services	10
1.4 THE IMPORTANCE OF SMART LIBRARY	11
1.4.1 The smart library's objectives	11
1.4.2 Dimensions of Smart Libraries	12
1.5 THE NEED FOR SMART PUBLIC LIBRARY	14
1.5.1 The status of libraries in Palestine	14
1.5.2 The status of libraries in Nablus city.....	16
1.6 THE MAIN FUNCTIONS.....	17
1.6.1 General functions of libraries.....	17
1.6.2 Smart public library’s functions.....	17
CHAPTER 2 CASE STUDY	19
2.1 INTRODUCTION.....	19
2.2 QATAR NATIONAL LIBRARY	20
2.2.1 Location	20
2.2.2 The Concept.....	22
2.2.3 Book sorter test, self-borrowing and return stations	25
2.2.4 Functions and spaces.....	25
2.2.5 Horizontal and vertical sections	27

2.2.6 Structure and materials	30
2.2.7 Air conditioning and lighting systems	31
2.2.8 Landscaping	31
CHAPTER 3 PROJECT PROGRAM.....	33
3.1 FUNCTIONAL REQUIREMENTS	33
3.1.1 Library spaces	33
3.1.2 Required library equipment	55
3.1.3 Library Vehicles	55
3.2 OPERATIONAL REQUIREMENTS	57
3.2.1 Entrance considerations	58
3.2.2 Lighting.....	58
3.2.3 Temperature and humidity	62
3.2.4 Colors.....	62
3.2.5 Noise reduction	63
3.2.6 Elevators and Stairs and ramps	64
3.2.7 Safety and security	64
3.2.8 Green spaces	65
PROJECT PROGRAM.....	65
3.3 FUNCTION’S RELATIONS	70
CHAPTER 4 SITE ANALYSIS	71
4.1 SITE SELECTION CRITERIA.....	71
4.2 SITE SELECTION	72
4.3 NABLUS CITY.....	72
4.3.1 Geographical location	72
4.3.2 Topography	74
4.3.3 Climate.....	75
4.3.4 Precipitation amounts.....	75
4.3.5 Relative humidity.....	76
4.3.6 Rainfall	76
4.4 THE PROPOSED SITE FOR THE PROJECT	76
CHAPTER 5 CONCEPT.....	78
5.1 CONCEPT DESIGN	79
5.2 PLANS.....	80
5.3 SECTIONS AND ELEVATIONS.....	81
5.4 PERSPETIVES.....	82
REFERENCES:	92

List of Tables

TABLE 3-1: THE INTENSITY OF LIGHTING IN LIBRARY SPACES	59
TABLE 3-2: THE APPROPRIATE TEMPERATURE AND HUMIDITY FOR LIBRARY SPACES	61
TABLE 3-3: PUBLIC AREAS	64
TABLE 3-4: ADMINISTRATION SPACES	65
TABLE 3-5: READING SPACES	66
TABLE 3-6: DIGITAL AREAS	67
TABLE 3-7: LIBRARY ARCHIVE	68
TABLE 3-8: PUBLIC AND CULTURAL SPACES	68
TABLE 3-9: CHILDREN SPACES	69
TABLE 3-10: OTHER SPACES	69
TABLE 3-11: TOTAL AREAS	70
TABLE 4-1: LAND LAWS ACCORDING TO THE CLASSIFICATION RESIDENTIAL C	80

List of figures

<i>FIGURE 1-1: CLAY TABLETS IN MESOPOTAMIA, ENGLAND. (SOURCE: THE BRITISH MUSEUM: ONLINE)</i>	2
<i>FIGURE 1-2: THE ANCIENT LIBRARY OF ALEXANDRIA. (SOURCE: THE ANCIENT BIBLIOTHECA ALEXANDRINA - THE LIBRARY OF ALEXANDRIA: ONLINE ARTICLE)</i>	2
<i>FIGURE 1-3: NATIONAL CENTRAL LIBRARY IN FLORENCE. (SOURCE: FLORENCEINFERNO, 2014: ONLINE)</i>	3
<i>FIGURE 1-4: AERIAL VIEW FROM THE SOUTH OF THE LIBRARY OF CONGRESS THOMAS JEFFERSON BUILDING, WASHINGTON, D.C., 2007, (LOC, PHOTOGRAPHER: HIGHSMITH, CAROL M.)</i>	4
<i>FIGURE 1-5: THE SEATTLE LIBRARY, 2004. (SOURCE: ARCHDAILY, 2009: ONLINE)</i>	4
<i>FIGURE 1-6: A PLAN OF SEATTLE LIBRARY. (SOURCE: ARCHDAILY, 2009: ONLINE)</i>	5
<i>FIGURE 1-7: FOUR DIMENSIONS OF THE SMART LIBRARY. (SOURCE: SMART LIBRARIES, JOACHIM SCHÖPFEL, UNIVERSITÉ DE LILLE, 2018: ONLINE)</i>	12
<i>FIGURE 2-1: QATAR NATIONAL LIBRARY IN DOHA, 2017. (SOURCE: ARCHDAILY, 2018: ONLINE)</i>	19
<i>FIGURE 2-2: THE MAIN PLAZA IN QATAR LIBRARY, 2017. (SOURCE: ARCHDAILY, 2018: ONLINE)</i>	19
<i>FIGURE 2-3: AERIAL PHOTO OF QATAR LIBRARY SITE. (SOURCE: GOOGLE MAPS, 2022: ONLINE)</i>	20
<i>FIGURE 2-4: THE VISUAL ANALYSIS OF THE SITE. (SOURCE: GOOGLE MAPS, 2022: ONLINE)</i>	21
<i>FIGURE 2-5: THE VISUAL ANALYSIS OF THE SITE. (SOURCE: INTELLIGENT SOLUTIONS, 2020: ONLINE)</i>	22
<i>FIGURE 2-6: BOOKSHELVES DISTRIBUTED IN THE FORM OF AN AMPHITHEATER. (SOURCE: INTELLIGENT SOLUTIONS, 2020: ONLINE)</i>	22
<i>FIGURE 2-7: THE THREE TIERS CONNECTED WITH BRIDGE. (SOURCE: INTELLIGENT SOLUTIONS, 2020: ONLINE)</i>	23
<i>FIGURE 2-8: FLOATING BRIDGE CONNECTS THREE TIERS. (SOURCE: INTELLIGENT SOLUTIONS, 2020: ONLINE)</i>	23
<i>FIGURE 2-9: INTERACTIVE MEDIA WALLS. (SOURCE: ARCHDAILY, 2018: ONLINE)</i>	23

FIGURE 2-10: THE TREE BOOK RETURN STATIONS. (SOURCE: ARCHDAILY, 2018: ONLINE). 24

FIGURE 2-11: SOUNDPROOFED BUBBLE CHAIRS. (SOURCE: ARCHDAILY, 2018: ONLINE). 25

FIGURE 2-12: INNOVATION STATION -3D PRINTING. (SOURCE: ARCHDAILY, 2018: ONLINE). 25

FIGURE 2-13: QATAR NATIONAL LIBRARY - HERITAGE LIBRARY SECTION. (SOURCE: ARCHDAILY, 2018: ONLINE) 25

FIGURE 2-14: GROUND FLOOR PLAN OF QATAR NATIONAL LIBRARY. (SOURCE: ARCHDAILY, 2018: ONLINE) 27

FIGURE 2-15: FIRST FLOOR PLAN OF QATAR NATIONAL LIBRARY (SOURCE: WIKIARQITECTURA: QATAR NATIONAL LIBRARY: ONLINE). 28

FIGURE 2-16: SECTION A-A SHOWING THE PONTOON BRIDGE (SOURCE: WIKIARQITECTURA: QATAR NATIONAL LIBRARY: ONLINE). 28

FIGURE 2-17: SECTION B-B. (SOURCE: WIKIARQITECTURA: QATAR NATIONAL LIBRARY: ONLINE). 28

FIGURE 2-18: ALUMINUM CEILING AND MARBLE FLOORS (SOURCE: ALANIARCHITECTURE, ONLINE) 29

FIGURE 2-19: CORRUGATED GLASS USED FOR ELEVATIONS (SOURCE: ARCHITECTURAL REVIEW: ONLINE) 29

FIGURE 2-20: LIGHTING AND CONDITIONING SYSTEMS. (SOURCE: ARCHITECTURAL REVIEW: ONLINE) 30

FIGURE 2-21: VARIETY OF AGRICULTURAL CIRCLES ON SITE. (SOURCE: ARCHITECTURAL REVIEW: ONLINE) 31

FIGURE 2-22: LIMESTONE DECK ON THE GARDEN FLOOR (SOURCE: ARCHITECTURAL REVIEW: ONLINE) 31

FIGURE 3-1: U-TOUCH INTERACTIVE TOUCH TABLE ZONE. (SOURCE: UTOUCH WEBSITE: ONLINE) 37

FIGURE 3-2: MEDIA WALLS ARE SITUATED AT THE LIBRARY'S ENTRANCE TO GREET GUESTS. (SOURCE: INDIAMART WEBSITE: ONLINE) 38

FIGURE 3-3: STANDARD DIMENSIONS OF DIGITAL TOTEMS. (SOURCE: ITATOUCH WEBSITE: ONLINE) 39

FIGURE 3-4: WAYFINDING KIOSKS OFFER HELPFUL DATA. (SOURCE: PHYGITAL EXPERIENCES - QATAR NATIONAL LIBRARY, ONLINE) 40

FIGURE 3-5: SPECIFIED DIMENSIONS OF THE WAYFINDING KIOSKS. (SOURCE: BSCENCLOSURES WEBSITE, ONLINE) .. 40

FIGURE 3-6: HEIGHT OF THE SEAT AND THE TABLE ACCORDING TO AGE GROUP. (SOURCE: CHAIR & TABLE SIZING

GUIDE, KIEUROPE WEBSITE: ONLINE).....	41
FIGURE 3-7: (4-5) SHELVES FOR A GROUP OF CHILDREN. (SOURCE: LIVING HOUSE WEBSITE: ONLINE)	42
FIGURE 3-8: SHELF HEIGHT FOR CHILDRENS. (SOURCE: LIVING HOUSE WEBSITE: ONLINE)	42
FIGURE 3-9: DOUPLE STUDY CARRELS AREA FOR EACH INDIVIDUAL. . (SOURCE: LIVING HOUSE WEBSITE: ONLINE) ...	44
FIGURE 3-10: DOUBLE STUDY CARRELS AREA FOR EACH INDIVIDUAL	45
FIGURE 3-11: COMPUTERS ABOVE THE TABLES IN THE ICT TRAINING ROOM. (SOURCE: WASHINGTON UNIVERSITY SCHOOL OF MEDICINE IN ST. LOUIS: ONLINE)	46
FIGURE 3-12: COMPUTERS BEEN LOWERED INTO THE TABLES. (SOURCE: WASHINGTON UNIVERSITY SCHOOL OF MEDICINE IN ST. LOUIS: ONLINE)	46
FIGURE 3-13: USING (AI) IN LIBRARY MUSEUM. (SOURCE: THE NATION THAILAND, 2019: ONLINE)	47
FIGURE 3-14: DIGITAL MAP USED IN LIBRARY MUSEUM. (SOURCE: THE NATION THAILAND, 2019: ONLINE)	47
FIGURE 3-15: SMART CONFERENCE ROOM, SAUDI ARABIA. (SOURCE: MEGATECH, 2020: ONLINE)	49
FIGURE 3-16: CONFERENCE ROOM DIMENSIONS. (SOURCE: ID WORKSPACE, 2020: ONLINE) MULTIPURPOSE HALL ..	50
FIGURE 3-17: ARRANGEMENT OF SEATS THROUGH MULTIPURPOSE HALL. (SOURCE: SALISBURY UNIVERSITY WEBSITE: ONLINE)	51
FIGURE 3-18: MAKERSPACES IN SMART LIBRARY. (SOURCE: THE MAKERSPACE OF THE EDMONTON PUBLIC LIBRARY (CANADA), 2019: ONLINE)	52
FIGURE 3-19: STANDARD DIMENSIONS OF CAFETERIA'S TABLES AND SPACES.	53
FIGURE 3-20: STANDARD DIMENSIONS OF BICYCLE PARKING. (SOURCE: DIMENSIONS WEBSITE: ONLINE)	55
FIGURE 3-21: STANDARD DIMENSIONS OF CARS PARKING. (SOURCE: MUNICODE LIBRARY: ONLINE)	55
FIGURE 3-22: DIMENSIONS OF SCHOOL BUS . (SOURCE: MUNICODE LIBRARY: ONLINE)	56

FIGURE 3-23: DIMENSIONS OF SCHOOL BUS PARKING. (SOURCE: MUNICODE LIBRARY: ONLINE) 56

FIGURE 3-24: SOFT AND CALM COLORS USED IN THE LIBRARY. (SOURCE: ARCHDAILY, GALLERY OF RIVER CENTER
BRANCH LIBRARY, 2020: ONLINE) 62

FIGURE 4-1: LOCATION OF THE CITY OF NABLUS ON THE MAP OF PALESTINE 74

FIGURE 4-2: NABLUS CITY MAP. (SOURCE: URBAN PARTICULATE MATTER HAZARD MAPPING AND MONITORING SITE
SELECTION IN NABLUS, PALESTINE, TAWFIQ SALEH AND ABDELHALEEM KHADER, 2022: ONLINE RESEARCH) .. 74

FIGURE 4-3: MAP OF NABLUS ILLUSTRATED WITH STREETS. (SOURCE: URBAN PARTICULATE MATTER HAZARD
MAPPING
AND MONITORING SITE SELECTION IN NABLUS, PALESTINE, TAWFIQ SALEH AND ABDELHALEEM KHADER, 2022:
ONLINE RESEARCH) 75

FIGURE 4-4: MAP OF NABLUS AND ITS TOPOGRAPHY. (SOURCE: URBAN PARTICULATE MATTER HAZARD MAPPING
AND
MONITORING SITE SELECTION IN NABLUS, PALESTINE, TAWFIQ SALEH AND ABDELHALEEM KHADER, 2022:
ONLINE RESEARCH) 75

FIGURE 4-5: AVERAGE TEMPERATURES AND PRECIPITATION OF NABLUS. (SOURCE: WEATHER AND CLIMATE, 2023:
ONLINE) 76

FIGURE 4-6: PRECIPITATION AMOUNTS IN NABLUS CITY. (SOURCE: WEATHER AND CLIMATE, 2023: ONLINE) 77

FIGURE 4-7: PROJECT LAND NEAR AN-NAJAH UNIVERSITY 78

FIGURE 4-8:ARRIVAL TIME FROM THE LANDMARKS SURROUNDING THE PROJECT LAND 79

FIGURE 4-9:MAIN AND SECONDARY SURROUNDING STREETS 79

FIGURE 4-10: LAND USE AND SURROUNDING LANDS 80

FIGURE 4-11: BUILDINGS SURROUNDING THE PROJECT LAND 81

FIGURE 4-12: EDUCATIONAL CENTERS SURROUNDING THE LAND 81

FIGURE 4-13: S ITE VISUAL ANALYSIS
82

FIGURE 4-14: PROJECT GROUND BOUNDARIES AND SURROUNDING STREETS
83

FIGURE 4-15: THE TOPOGRAPHY OF THE SITE 83

FIGURE 4-16: SECTIONS SHOWING THE SLOPE OF THE GROUND
84

FIGURE 4-17: SUN PATH IN SUMMER
84

FIGURE 4-18: RELATION BETWEEN THE AZIMUTH ANGLE AND THE ELEVATION IN SUMMER
85

FIGURE 4-19: SUN PATH IN WINTER
85

FIGURE 4-20: RELATION BETWEEN THE AZIMUTH ANGLE AND THE ELEVATION IN WINTER
86

FIGURE 4-21: WIND SPEED IN NABLUS CITY
86

FIGURE 4-22: WIND ROSE DIAGRAM
87

FIGURE 4-23: THE DISTURBANCE AROUND THE SITE
88

FIGURE 4-24: SHADING ANALYSIS IN THE MORNING AT 8:00 AM
89

FIGURE 4-25: SHADING ANALYSIS IN THE NOON AT 12:00 PM
89

FIGURE 4-26: VIEW ROSE OF THE SITE
90

Chapter 1 Introduction

The genesis of books came with the emergence of language on the one hand and art on the other hand, in societies that did not know any kind of writing, and oral communication was the only means of exchanging ideas.

1.1 The establishment of libraries

1.1.1 Definition of Library

A library is an organized collection of knowledge resources made available to the community for research, viewing, and borrowing. The broader meaning Often printed books go beyond in their narrow sense and now include with them a large number or a little paper material others, such as newspapers and other periodicals of all kinds, as well as maps and atlases it may also include ancient heritage manuscripts, correspondence, recent notes, and other non-printed paper materials. Thus, the library is a place for collecting information resources, and services and is organized for use that is sponsored by a political body or institution. [1]

Modern libraries have become common nowadays which can be defined as open places to access information in its various forms and multiple sources, and provide services for specialists in the field of organizing and searching for information. In recent times libraries have gone beyond the walls of the building to contain materials that can be collected electronically. The term library has another meaning, which is a collection of useful materials for public use.

1.1.2 Historical Development of Libraries

Early libraries (c. 2600–800 B.C.)

The first ancient libraries contained archives of ancient writing, which was previously known in clay, written tablets and manuscripts in the cuneiform script were found in Sumerian temples in Mesopotamia, some of them go as far back as 2600 B.C.E. as shown in figure (1-1). In ancient Egypt, we see government records and current events written on papyrus. [2]



Figure 1-1: Clay tablets in Mesopotamia,

Classical period to Middle Antiquity (800 BC –

330 AD) The greatest and most important ancient library *England*. (Source: *The British Museum: Online*)

was located in Egypt, and its name was Library of Alexandria. From the time of its construction in the third century BC through the Roman invasion of Egypt in 30 BC, it thrived under the patronage of the Ptolemaic dynasty and served as a significant center of learning. Either Ptolemy I Soter's (323-283 BC) or his son Ptolemy II's reigns saw the conception and opening of the library (283–246 BC). The library contained more than half a million scrolls. Figure (1-2) shows us the building of the ancient Library of Alexandria.[2]

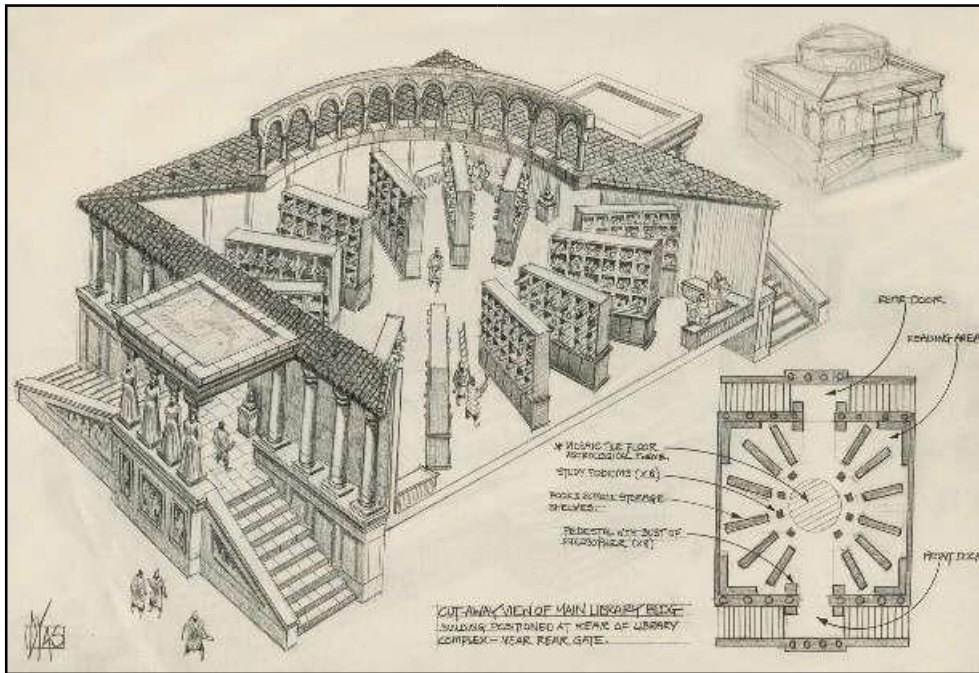

Figure 1-2: The ancient Library of Alexandria. (Source: *The Ancient Bibliotheca Alexandrina - The Library Of Alexandria: Online Article*)

Late antiquity and middle ages (330 AD – 1400 AD)

During antiquity and the middle Ages, about 28 public libraries were produced in Rome, after the Roman imperial capital was transferred to the city of Byzantium (Constantinople) in 330 AD under the rule of Constantine the Great, the empire was divided and later unified. During this period, society changed as it was filled with Christian clergy, and then a number of books and libraries grew and moved east towards the Byzantine Empire with the disintegration of the West. There, four separate kinds of libraries—imperial, patriarchal, monastic, and private were founded. [2]

17th- 18th centuries

A period of time known as the "golden age of libraries" occurred in the 17th and 18th centuries; during this time, some of the most significant libraries in Europe were established, such as the National Central Library in Florence which are



Figure 1-3: National Central Library in Florence.

(Source: florenceinferno, 2014: Online)

illustrated in figure (1-3). The birth of the

functional library can be seen during the 18th century, which is regarded as a turning point in all cultural advances in the history of libraries. [2]

19th-20th centuries

Since the nineteenth century, the library has begun to carry out its responsibilities toward the general public through the elite, and perhaps the library association the elite has earned it a prestigious position, so the library has become part of the prestige that some rulers have added to themselves, such as Ptolemy and Charlemagne



Figure 1-4: Aerial view from the south of the Library of Congress Thomas Jefferson Building, Washington, D.C., 2007, (LOC, Photographer: Highsmith, Carol M.)

established libraries of their interest in literature and knowledge, and they attracted scholars and researchers; [‘ppp libraries that were founded at that time the Library of Congress as we can see in figure (1-4) which is considered one of the largest that was established in 1800 AD and contained 800,000 volumes. [3]

21th century

We can call the 21st Century library the smart library. As the digital aspect includes the digitization of information sources, their compression and storage in digital and textual form and in the form of sound, image and graphics. It is the job of librarians to manage both analog and digital collections. By the end of 2018,



Figure 1-5: The Seattle Library, 2004.

(Source: Archdaily, 2009: Online)

326 million loans of eBooks' and audio books had been made in libraries worldwide, setting a record high. Easy-access digital library cards and online book groups are becoming more and more common. In addition to books, various digital resources draw users to libraries. Maker spaces, often referred to as hacker spaces, offer a place for library patrons to experiment, create, and mingle. Many may also have recording studios for video and audio, replete with cutting-edge computers that enable users to edit their works. In order to

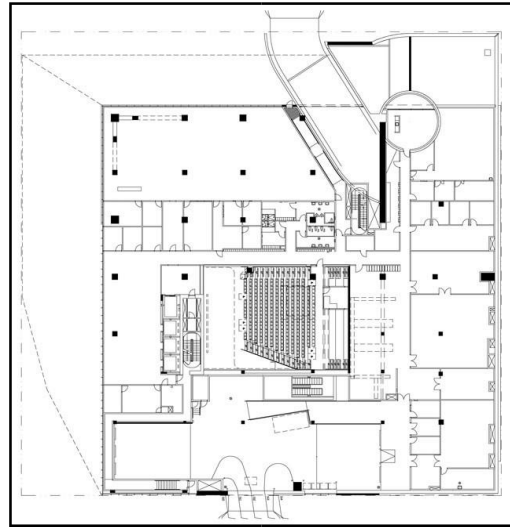

Figure 1-6: A plan of Seattle library.

(Source: Archdaily, 2009: Online) enhance, modernize, and grow libraries, we must use smart technology as we move in this era of digital technology. These cutting-edge technologies are boosting the number of people and visitors to the library. This is due to the completely tailored system's assistance, which enables library users to execute work without assistance from staff members and without idly squandering their valuable time. It has cutting-edge technology installed. Additionally, the smart library's automatic doors, public PCs, and self-service kiosks may all

be controlled remotely. [4] This system was developed with library users in mind. Through Figure 1-5 we can see the building of the Seattle Library (2004 AD) designed by Rem Koolhaas. This library is considered one of the first examples that changed the traditional library design. In the Seattle Library, information has been preserved in traditional and modern ways, and the library has been designed with modern architecture. Figure (1-6) shows a plan of Seattle Library.

1.2 Types of libraries:

Libraries differed and proliferated depending on the kinds of people who used them and came to visit, as well as the kinds of collections they housed. Additionally, it depends on the objectives and functions for which it was discovered.

The types of libraries can be summarized as follows:

1.2.1 Public Library

Public library it is the cultural and social institution that collects sources of knowledge in all its forms and types and serves all citizens without exception, and does not place any restrictions on its properties, and provides sources of information in all its forms and types.

[5]

Public library properties

- To be for the general public without any distinction or discrimination.
- To provide all services free of charge.
- To be established and supervised by the state.
- To provide the opportunity for children to carry out their activities or cooperate to advance their intellectual and cultural level as they are the men of tomorrow.

The goals of public library

- Acquisition, preparation and organization of various office materials so that they are accessible to readers.

- Providing various office services to all citizens without exception.
- Encouraging the public to read and benefit from the various resources in the library.
- Raising the career level of individuals through their review of the latest developments in their field of work and specialization.
- Supporting social relations between members of society.
- Collecting and preserving information and documents related to the city and neighborhood in which the library is located.
- Support other nearby libraries, especially school libraries.

1.2.2 National Library

National libraries exist in all countries of the world - except in Palestine - if they are the official libraries the state and these libraries are major institutions established by states to be a repository for official activity for these countries in the field of research, authoring, publishing, and everything related to knowledge culture, and mostly there shall be one library for each country in its capital, such as the Library of Congress in Washington and the Lenin Library In Moscow. It follows the legal deposit rule in collecting the national intellectual heritage. The legal deposit is the law that requires an author or publisher to deposit a number of free copies of a Publications or books issued in the National Library, in return, the state protects these the authors have the rights to their ideas in their works, and the publication takes a deposit number before it is published. [6]

1.2.3 School Library

School libraries are associated with learning and study. So it was created with the establishment of temples and monasteries and the mosques in which teaching seminars were held, but their definition has changed in the modern era accordingly to change teaching methods and educational and educational goals that are concerned with preparing a good

citizen by training him on methods of self-learning and scientific thinking, and developing his abilities and skills to be a citizen able to serve his country. [5]

Definition of school library

That library attached to schools, whether primary, middle or secondary and the librarian who supervises the Managing and providing services to it. School library aims to serve the component school community from students and teachers. It considered part of the school curriculum, which is the tool that through which the educational goals of the school are achieved. [5]

1.2.4 Academic Library

A library that is a part of a higher education facility that supports the curriculum of the institution as well as the research needs of university teachers and students in complementary ways. [5] An example of university libraries in Palestine is the An-Najah National University

Library in the New Campus.

1.2.5 Specialized library

This library is concerned with a field .It is one of the fields of knowledge, and it aims to enrich its shelves with information and its sources in all its forms in relation to one field only, and it is often affiliated with an institution or organization and provides information regarding the activity and objectives of this institution. [5]

1.2.6 Children's library

This library takes care of the child and develops his abilities to refine his cultural personality and instill in him a love of reading. [5]

1.2.7 Mobile library

Electronic library: It is also called the virtual library, and this type of library appeared in conjunction with era of the technological revolution that the world has witnessed recently, and it is a library that is not linked to realistic restrictions, and has no structure or Walls. Due to their non-existence on the reality, they are devoid of printed sources of information its

holdings are all electronic or digital, and these libraries are distinguished by their availability all the time, and they are not restricted to a specific time, that is the researcher can access the information 24 hours a day, and more than one researcher can access it at the same time to one subject and its use, it is also characterized by its ease of use by the researcher. [5]

1.2.8 Smart library

Library and information sciences have created new ideas for marketing and advocating for public and academic libraries in response to recent social and technical problems. Some of these ideas have had an effect and have been somewhat successful in influencing the underlying principles, missions, and visions of a new generation of libraries. One of these ideas is the phrase "smart libraries," which is a part of a bigger revolution that is the drive to "smart cities," which are built on a number of components that are expected to alter how we work, shop, communicate, and move about. Smart libraries can be any of the libraries mentioned above, connected to a modern technological system that feeds our libraries with more and more reading and enjoying the techniques of this library.

1.3 Smart library

1.3.1 Definition of Smart library

It is a group of hardware and software that provides users with a difference of search options and gives them the ability to request information and get what they need from it. We can also define it as "a library that provides interactive, innovative, advanced, educational, realistic and global services". The word of Smart refers to something that is "adaptable, flexible, extendible, acknowledging, and human". [7] The purpose of smart library is that it provides all library services to its customers faster, better and smarter through what it offers intelligent readers IoT and AI-based services. Its generates: new knowledge, a smart environment, and mobile access Also gives an Active content, adaptive design, and intelligent technology of content development in addition to Smart knowledge detection, Smart interface

(Organization of the user's interaction) and Intelligent services (such as personal informing, and usage of mobile applications.

What can a smart library help individuals?

- You can use the self-service kiosks to borrow, return, and renew library materials when the Smart library is open
- Pick up reserved things that are waiting for you to pick them up at the reservation collecting point, then use the self-service kiosks to borrow them
- Use the free Wi-Fi and public computers in the library
- Print, copy, and scan documents using public computers
- Use public computers to access and browse the library's online catalogue
- Rent a conference room (before reservation)

1.3.2 Technologies for smart library services

Librarians should examine emerging technologies for providing high-quality, effective library services. Cutting-edge technologies can be used for smart library services, such as:

Cloud Computing

A developing technology, cloud computing presents prospects for libraries that must give consumers endless or timeless services. Cloud computing is a virtual platform that is userfriendly. It allows on-demand access to shared computing resources with the least management or service provider involvement. [8]

The Internet of Things

(IoT) is a stage in the growth of the internet that creates a worldwide infrastructure for humanmachine communication. It employs nodes (sensors) to broadcast information to users or any other devices through the internet. Its gadgets are connected to one another in order to construct schemes for certain purposes. [8]

Artificial Intelligence (AI)

Machine intelligence is another name for artificial intelligence. In contrast to the natural intelligence exhibited by people and other animals, this intelligence is one that robots have proven. Speech recognition, learning, planning, vision, logical reasoning, and problem solving are some of the tasks that AI is intended to perform. It may be set up to automatically give information to users at predetermined times without the need for librarian interaction.

[8]

3D Printing

Technology for fabricating three-dimensional (3D) structures layer by layer directly from computer-aided design (CAD) drawings has evolved into 3D printing. For libraries trying to increase the efficiency of printing and publishing, it opens up new options. The information industries have been transformed by 3D printing technology. In the disciplines of knowledge, the use of this technology allows mass customization and manufacture of any kind of open source designs. [8]

Radio Frequency Identification (RFID)

The most recent technology being utilized in libraries to provide security and enable cuttingedge services is RFID. It is an autonomous radio communications system that identifies documents through wireless radio transmission. Utilizing tags (transponders) on which data can be written and updated, an RFID system may also be used to store data. [8]

1.4 The importance of smart library

1.4.1 The smart library's objectives

Group management

It covers all the procedures leading to the identification of information sources that satiate the precise and genuine requirements of beneficiaries, as well as the procedures leading to the acquisition of information from these sources, including supply chains. [9]

Controlling beneficiary information

It covers all activities that result in the gathering of beneficiary information about their categories, as well as information about their precise and actual needs based on these categories. [9]

Big data evaluation

It covers all activities that result in the analysis of all data gathered during the library's work processes, including those that involve group and beneficiary data, activities, and decisionmaking during the design, implementation, and creation of services and applications. [9]

Building administration

To keep the environment sustainable in terms of energy conservation, by making the best use possible of air conditioners, lighting, and water. [9]

1.4.2 Dimensions of Smart Libraries

Recently, the phrase "Smart Library" has been more frequently used to describe a futuristic vision of libraries, particularly as it relates to the so-called "Smart City" concept. This idea focuses on the integration of digital processes and informational feedback loops in the public infrastructure and asserts that this integration is an ideal state in which cities become "smarter," or more effectively organized, resource-friendly, flexible, sustainable, green, and socially inclusive. The Smart Movement (SM) comprises four dimensions which is: smart services, smart people, smart places, and smart governance, as shown in figure (1-7). [9]

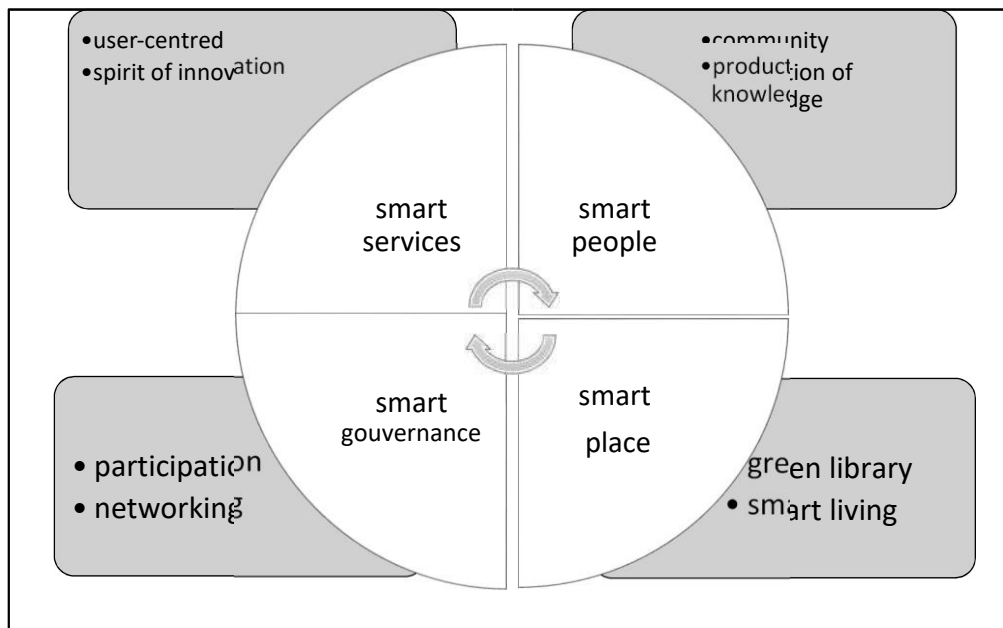

Figure 1-7: Four dimensions of the smart library. (Source: *Smart Libraries*, Joachim Schöpfel, Université de Lille, 2018: Online)

Smart Services

It is the first dimension, which can be summed up as the "spirit of innovation" of smart readers being applied to the creation and putting the contemporary library services. The library services may be made available to readers via RFID, mobile and wireless access, remote assistance, semantic web, AI, IoT, machine translation, voice and image recognition, sensor, CCTV, natural language processing, augmented reality, and other means. [9]

Smart readers

It denotes building-related smart living and entails things like building monitoring and control, electrical device monitoring, personal safety, and a healthy atmosphere for both the workers and the general public. Readers of smart library ought to value adaptability, inventiveness, and involvement in society. [9]

Smart place

The library is both a building and a place, according to the third dimension. This component can be broadly characterized as "smart environments" and environmental monitoring. For

readers to sit comfortably and read effectively, the location should be technologically and environmentally smart. [9]

Smart Governance

The final dimension of the smart library. It includes all library components that, in the state or country, represent the idea of "smart governance," including things like cooperation, partnership, engagement of citizens, and participation. The patron of the library becomes an active participant in the administration and management of the institution. Collective intelligence, based on delegated responsibilities between library staff, the library community, and other institutions, is the key component of smart governance. [9]

1.5 The need for smart public library

Why do we need this type of project in our Palestinian community?

Our present and future will be bright and full of these educated youth energies who will use their scientific weapon to confront their reality, present their ideas, and spread their views to the entire world if we do everything in our power to promote science and culture and encourage our children and youth to turn to science, reading, and permanence in libraries. Because, knowledge is the weapon of the Palestinian people with which they can face the crimes of the occupation and to defend their land, heritage and homeland.

1.5.1 The status of libraries in Palestine

The Palestinian Museum, which is one of the projects of the "Al-Taawon" Foundation (founded in 1983 at the initiative of Palestinian businessmen), issued a list of 108 public libraries in historic Palestine, through a survey study aimed at assessing in general the state of public libraries and exploring the extent to which the number of readers has decreased in these libraries. Borrowing books. Also The Museum further noted that seven libraries all in the Gaza

Strip were either entirely or partially destroyed and that there are currently 21 libraries in Palestine that are closed. There are 8 libraries in Jerusalem, although 6 of them are currently closed. [10]

The list also contained a brief description of each library, detailing things like the building's condition, the number of volumes, the number of subscribers, borrowing patterns, the systems in place, and other things. But one thing they share is a low readership and a low rate of book borrowing. The libraries destroyed as a result of the Zionist aggression in recent years were also discussed, most notably the library of the “Al-Taghreed Association” in Beit Hanoun, which lost about 10,000 books, the library of the “Al-Ataa” charity association, and the library of “Al- tuffah Sports Club” in Gaza, which both lost Approximately 7,000 books, in addition to the Al-shajaieh Club library in Gaza, which lost its entire contents, estimated at 6,000 books. We can see from this content that Israel targeted Palestine and the Palestinians, not just the land, but also the human being with all of its components, ideas, and traditions. The Nakba and the ongoing atrocities of the occupation are documented in libraries, which are and they are a record of the Nakba and the ongoing crimes of the occupation. [10]

[Libraries in Gaza](#)

In the Gaza Strip, the largest library in terms of number of books was the “Bani Suhaila” municipal library, which owns 40,000 books, but the library has been closed since 2008, followed by the Gaza municipality library, which contains 25,000 books, and then the “Khan Yunis” municipal library with 20,000 books, in addition to the Rafah Municipality Library and the Maghazi Society for Community Rehabilitation, which each contain 15,000 books, and the Qattan Center for Educational Research and Development Library, which contains 10,000 books. [10]

Libraries in Jerusalem

As for the occupied city of Jerusalem; The "Palestinian Museum" has monitored the presence of 8 libraries, 6 of which are closed, but most of them are the oldest and most ancient, such as the "Badiria" library, which was established at the end of the eighteenth century, and today preserves about 1,200 manuscripts and 2,200 books, and the "Khalidiya" library, which was established in 1899, and they contain 1,800 valuable archaeological manuscripts, and are distinguished by their containing manuscripts from the Middle Ages, and the oldest book in them dates back to the thirteenth century. [10]

1.5.2 The status of libraries in Nablus city

Finally, in the city of Nablus; four libraries were discussed, the largest of which is the Nablus Municipal Library, which was established in 1960 and contains 125,000 books. It also has an “impressive” archive on the history of the city of Nablus, containing numbers of Arab newspapers, historical documents and municipal files dating back to the twenties of the last century. But what do we want to point out that there are many problems and obstacles that the Nablus Municipal Library suffers from, the most important of which are: First: The political problem due to the occupation (1987), where activities are restricted and the library cannot perform its normal duty in terms of the quality and number of books. Second: The current building does not accommodate the library and expands it to meet its various needs, as there is a clear shortage in the children's corner and insufficient space for the staff to do their work in the best way. Therefore, there must be a need for a large library that meets these needs, in addition to this the needs should keep pace with our present and future and help people to move forward and strive more to read, learn and culture in a spirit full of passion. [11]

1.6 The main functions

1.6.1 General functions of libraries

The general functions of the library can be explained like this:

The acculturation function: which aims to make individuals educated and have a lot of information in all fields. It provides individuals with all the services, resources and books that enable them to develop a sense of knowledge and art and train them to coexist with the circumstances and atmosphere around them.

The educational function: which is divided into two parts, is to provide full support to the school library, and the second is its role in helping adults learn and knowledge by providing them with the books they need.

The media function: which aims to provide all the important information about any event or issue that occurs in the world, especially the important issues that many people wonder about.

Recreational function: It aims to provide people with materials for their amusement while adding information during their free time, and these materials can be books or recordings, whether visual or audio, magazines, and any publications in general. [12]

The modern library, in addition to reading rooms, should provide additional spaces and spaces with various and different functions such as: spaces for individual or group study and work and spaces dedicated to the use of new media, including to support the educational process, and for social communication. Do not forget that the functions of smart libraries include the creation of systematic collections, preserving and organizing knowledge and information in digital form, then enabling simple and inexpensive access to it from many online sites.

1.6.2 Smart public library's functions

We can summarize the functions and spaces needed in this project as follows:

- The reading zone: Reading spaces, Digital reading hall and Children's area
- Return and borrowing area
- Reader' services area

- Quiet Studying areas:
- Social areas: multi- purpose hall , Smart conference room, maker spaces and
- Digital museum.
- ICT technology spaces: ICT training room and ICT quiet room.
- Administration
- Staff area
- Services: Comfort zones, Café and W.Cs.

Chapter 2 Case study

2.1 Introduction

We can say that with the advent of information technology, there has been a remarkable transformation in both public and academic libraries. Where these libraries began to provide digital services and ease of access to information through modern technology. This would make the libraries more relevant and participate in their society by resorting to new ways of communication and social participation and meeting the needs of their users. With the emergence of modern libraries in the twenty-first century, the concept of "three-dimensional" space appeared, which raised the tasks of libraries by transforming spaces from the traditional place for books into spaces for the interaction of young people and children and strengthening their cognitive, social and educational sense.

With the digital age, new library spaces have become spaces that include new systems, digital platforms (media walls), and touch screens. The twenty-first century has witnessed a new movement in the establishment of libraries, and among these libraries there is the Qatar Smart National Library. The State of Qatar is one of the countries that places a strong emphasis on education and that it is in line with the Qatar National Vision 2030. A project has been completed that stimulates social communication, brings people together and focuses on equal access. For culture and information materials, this is a long-awaited project in Qatar. Where an idea emerged to establish a library that serves Qatar's society, institutions and universities, the project was changed in April 2012 and was called Qatar National Library, which was identified as the National Public Library and Research Library, and from which the Library was transferred from the previous library to the new national library. We will highlight in this research about the Qatar National Library building, which provides access to information

both physically and digitally, as well as places for interaction and learning, making it the library of the twenty-first century. [13]

2.2 Qatar National Library

The library opened its doors on November 7, 2017. The number of visitors during the first week reached 18,500, and the library organized several events. The National Library was established by the architect Rem



Figure 2-1: Qatar National Library in Doha, 2017.

Koolhaas in Qatar, in the capital, Doha, (Source: Archdaily, 2018: Online).

with an area of about 45,000 square meters, to help explore the development and progress of knowledge from the past to the present. [13]



Figure 2-2: The main plaza in Qatar library, 2017.

while the project was completed in (Source: Archdaily, 2018: Online).

2017. As shown in figure (2-1), the design of the external building takes the form of two separate panels folded diagonally at the edges to give and form a container like a shell that surrounds the open interior plan (the main plaza shown in figure (2-2)). [13]

2.2.1 Location

On campus, the Education City 36,012 square meter site for the National Library Building takes a prime position. The Central Library and Convention Center represent the center of the campus from the highway, and the National Library is likely to become one of the major visual icons of Education City as a result of the proposed improvement of the existing

highway to motorway condition and the projected increase in use from the road. The aerial photo shows the location of the library, as in figure (2-3). And what we know about the architect Rem

Koolhaas and his style in architecture, we see from the shape and borders of the building and its fragments that dominate the deconstructive architecture style in addition to its square shape, and this distinguishes it from the surrounding building The site will increasingly become a center for the academic community due to its visibility and accessibility from the Convention Center, Specialty Teaching Hospital, Weill Cornell Medical College, the headquarters buildings of Qatar Foundation and Georgetown College of Foreign Service .As shown in figure (2-4) we see the visual analysis of the site.



Figure 2-3: Aerial photo of Qatar library site. (Source: Google Maps, 2022: Online).

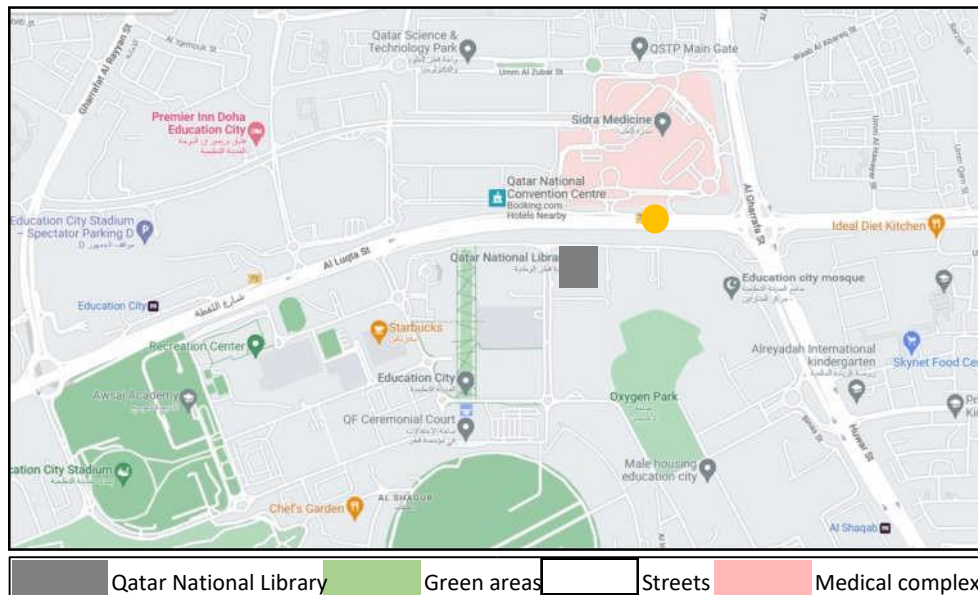

Figure 2-4: The visual analysis of the site. (Source: Google Maps, 2022: Online).

2.2.2 The Concept

With the advent of modern technology devices and techniques, books are turning to museums to display them as a model for antiquities of the old time. But thanks to the architect Rem Koolhaas and his role in giving the library a role and a new vision, we can see the continued flourishing of libraries. The architect Rem’s vision for libraries is to change the traditional view to a view that more expresses the nature of learning and reading and resorting more to libraries so that it becomes a place for interaction and participation among users not only with Books, but also to develop their skills, also a place to work and a place to gather to discuss, express opinion and spend time that people enjoy.

If we look at the building from the top, we see it is square and flat in shape. By dispensing with being thrown upwards like other buildings to give greater volume, the design team proceeded with the idea of raising an edge of the square below which the office and service spaces were placed and raising two opposite corners of it were raised below them two entrances were placed that take visitors and users to the center of the building. The figure (2-5) illustrates the architectural idea in designing the building. [14]

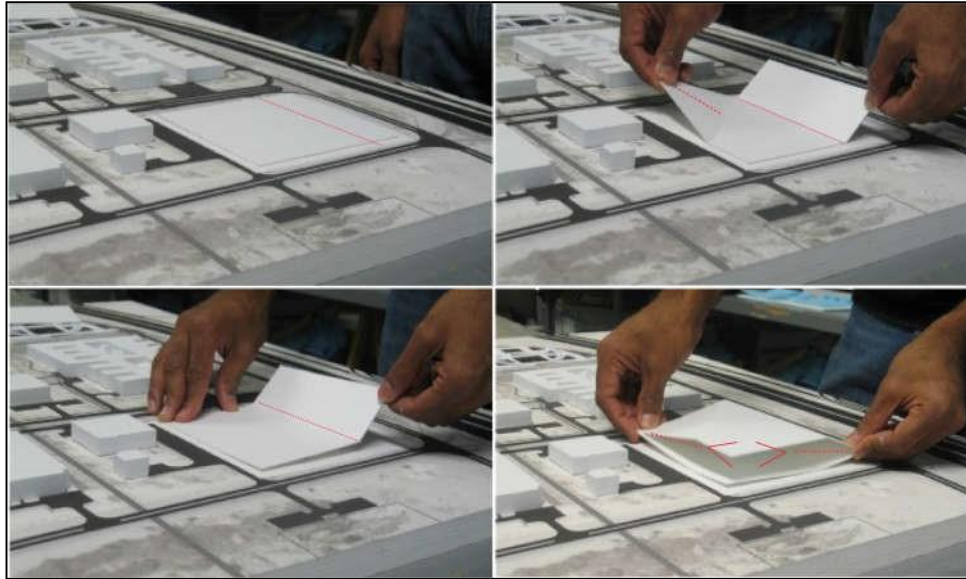

Figure 2-5: The visual analysis of the site. (Source: Intelligent Solutions, 2020: Online).

Another concept that was used is the bookshelf area. Bookshelves distributed in the form of an amphitheater and sitting on the steps of the stairs in a large playground that cheers visitors and users as they enter the plaza that what we can see in figure (2-6).



Figure 2-6: Bookshelves distributed in the form of an amphitheater. (Source: Intelligent Solutions, 2020: Online).

Overview of library building and descriptions

The white concrete ceiling rises about 21.22 meters and there is a floating bridge that connects three tiers as shown in figure (2-7) and figure (2-8) shows the floating bridge. We can interpret the height of the book area as a symbol of knowledge and values, as if we see a Roman theater. Reflective coatings add

Space and reflection inside the building, while glass facades allow communication with the Outside.

The design of the library came to accommodate 1,200,000 books arranged and distributed on compact shelves and layers, while now the library includes about 1,000,000 books. Daily the library accommodates 1000 visitors and seats are distributed over the square with a capacity Of 800 seats. [15]

There are four media walls standing on their opposite sides at the entrance area in the library. These walls consist of four interactive screens that include news about the library, information, events, additions of

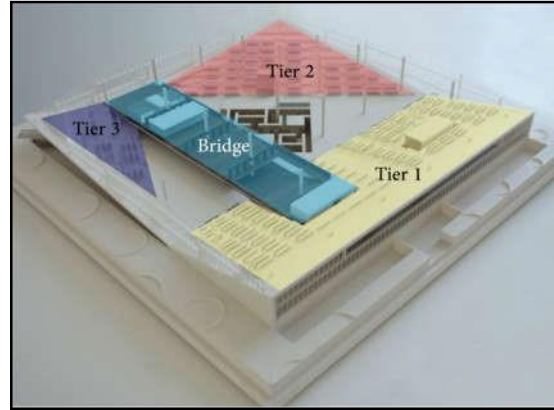

Figure 2-7: The three tiers connected with bridge.

(Source: Intelligent Solutions, 2020: Online).



Figure 2-8: Floating bridge connects three tiers. (Source: Intelligent Solutions, 2020: Online).



Figure 2-9: Interactive media walls. (Source: Archdaily, 2018: Online).

new books and digital postcards. What distinguishes this library is the ability to independently record and download borrowed materials and books in it, where there are 18 self-renting stations along the shelves, while the six return stations are located inside the yard, one at the entrance area and the other outside the library. [15]

2.2.3 Book sorter test, self-borrowing and return stations

The idea of a place for sorting books was implemented to help users and meet their needs inside the library. The returned materials are received, distributed and transported through a set of belts that are transported to the section defined for them, and this is known as the book sorter function, and then they are returned and put in the appropriate place on the shelf. We see in Infrastructure of the building is a building dedicated to conveyor belts sorter books. The sorter reads the location code of each book and transfers it to the belt to the sorter's return station.

The sorter is integrated with digital library systems and an RFID terminal where the



*Figure 2-10: The tree book return stations.
(Source: Archdaily, 2018: Online).*

station reads the tag to see if the book belongs to the library or not. The figure (2-10) shows the three book return stations near the entrance area.

2.2.4 Functions and spaces

There are many different spaces and areas for each of the categories. For example, there is an area that enhances the experience of people with special needs, which is the assistive technology area, which includes specialized programs and equipment, and a youth area with 6 gaming booths. The library includes digital exhibitions and 28 carrels for students and laboratories such as a computer lab. It includes 6 halls, including for meetings and another hall for celebrations with a capacity of 120 seats. There is an area that occupies a capacity of

127 seats known only for special occasions such as lectures or some concerts as well as conferences and so on. And in the main square where it includes a cafe area the space for sitting, relaxing and calming is provided by soundproofed bubble chairs as shown in figure (2-11).

The restaurant offers buffet service and à la carte menu, and activities within it are provided as activities and cooking lessons. The four innovation stations have been developed and equipped with sound insulation, some technologies and equipment, in addition to music programs, photo studios and printers such as a 3D printer as we can see in figure (2-12).



Figure 2-11: Soundproofed bubble chairs chairs. (Source: Archdaily, 2018: Online).

These stations serve the members and provide them with sufficient space for cooperation and entrepreneurship. As for the children's library, it was designed for children up to the age of 11, and it invites children to entertain, share, learn and read. It has a capacity Of about 50,000 books.



Figure 2-12: Innovation station 3d printing (Source: Archdaily, 2018: Online).

While the heritage library is located on the basement floor, as shown in Figure (2-13), where it was built with Italian marble and has its own entrance. This library consists of 11 sections containing 26000 books of precious and rare books, 1200 maps and globes, in addition to containing manuscripts estimated at about 4000 manuscripts on Islamic and Arab civilizations.



Figure 2-13: Qatar National Library - Heritage Library section. (Source: Archdaily, 2018: Online)

2.2.5 Horizontal and vertical sections

On the ground floor, we see most of the functions of the library in addition to the horizontal and vertical movement and the main entry area of the library, where the access to the ground floor is through an inclined entrance and what accepts the entrance from large screens that benefit and give a survey to the visitors of the library some of the services, and among these services are readers and inquiries services, staff areas, spaces for borrowing and returning books In addition to a library for children, reading areas, a café, and a restaurant. The middle floor is the Heritage Library, which is located on the floor below, and is accessed by stairs and small elevators. [14] The figure (2-14) shows the ground floor plan and the functions that permeate it.

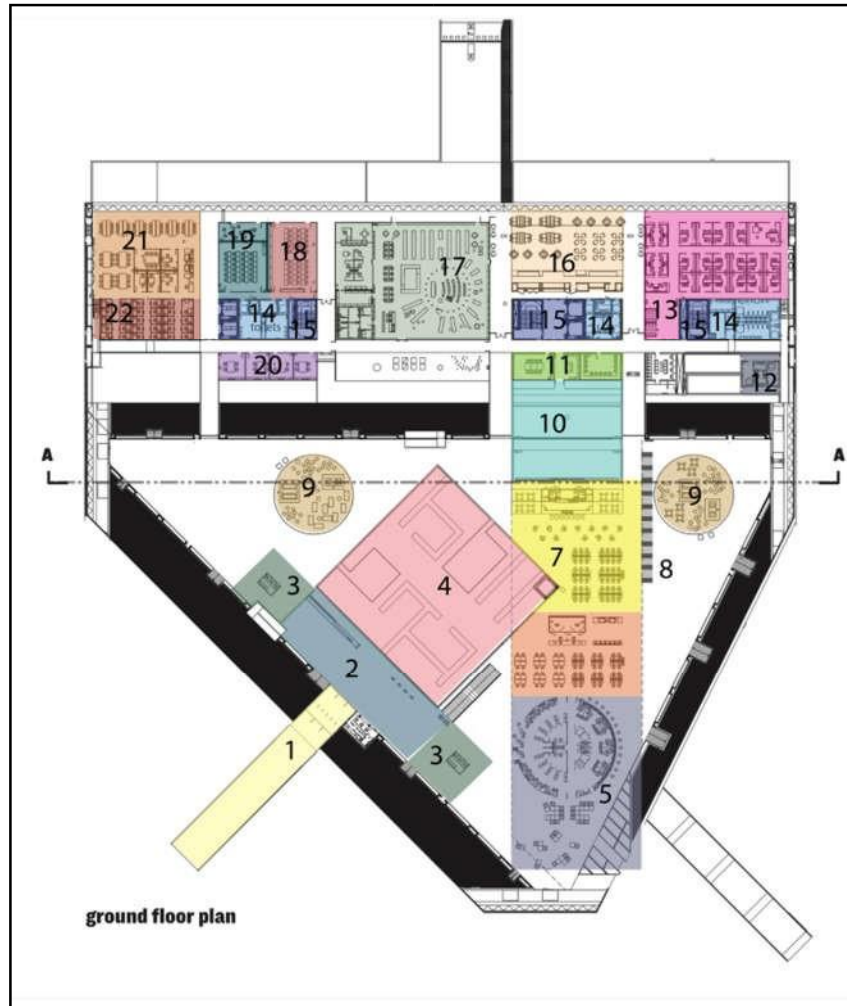

Figure 2-14: Ground floor plan of Qatar national library. (Source: Archdaily, 2018: Online)

Through the first floor, areas of bookshelves appear, and this floor contains several spaces, including reading areas ,exhibition area , auditorium, lounge and public computers as shown in figure (2-15).And according to figure (2-16) we can see the section A-A and section B-B in figure (2-17).

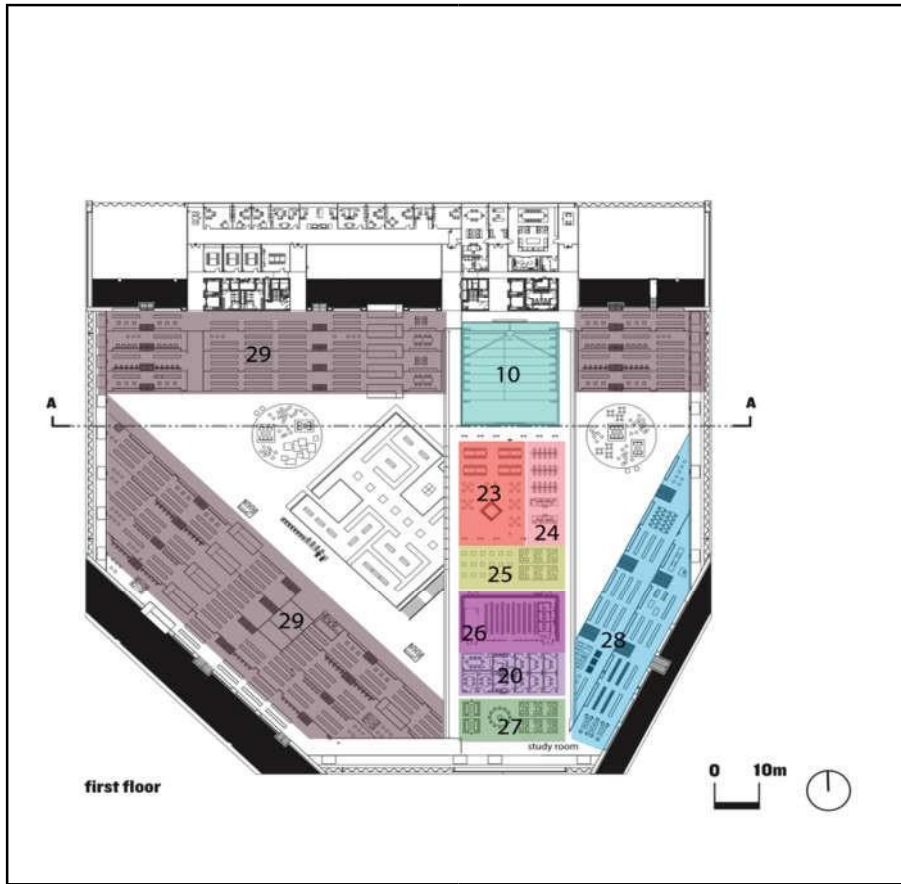

Figure 2-15: First floor plan of Qatar National Library (Source: wikiarqitectura: Qatar National Library: Online).

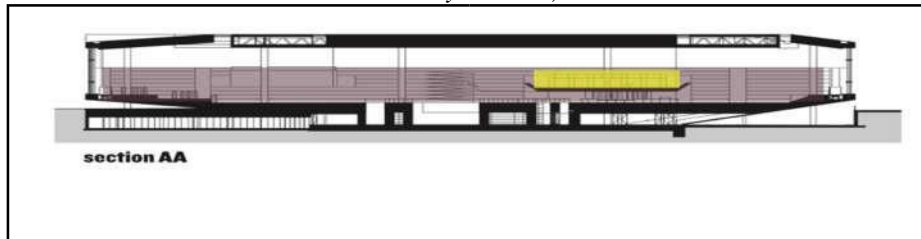

Figure 2-16: Section A-A showing the pontoon bridge (Source: wikiarqitectura: Qatar National Library: Online).

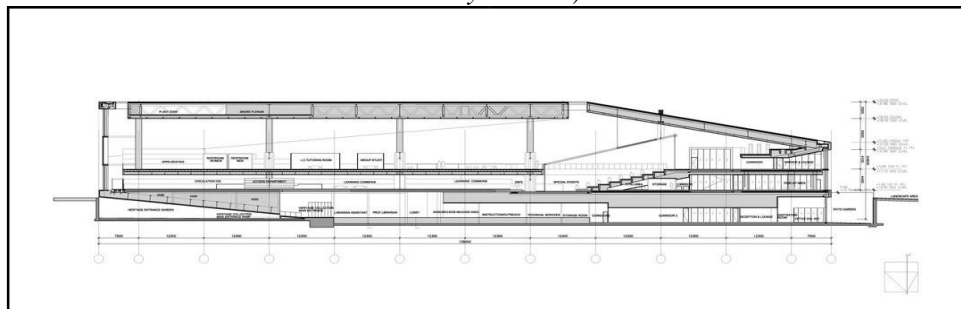

Figure 2-17: Section B-B. (Source: wikiarqitectura: Qatar National Library: Online).

2.2.6 Structure and materials

When going to visit the library, the visitor notices the basic materials that make up the building. From the outside, he sees the concrete ceilings and walls of the building and the corrugated glass facades, and from the inside he sees the reflection of the marble floors and the harmonious white (Source: *alaniarchitecture, Online*) ceilings of aluminum as shown in figure (2-18).



Figure 2-18: Aluminum ceiling and marble floors

The building almost flat, so it was a challenge to the external environment in Qatar due to the high temperatures. The structure of the library building is steel supported by 34 columns that have been covered with panels of prefabricated concrete and as if the building seems to us that it is made entirely of concrete, the concrete panels appeared in their natural color and Reflective surfaces.

Corrugated glass: Through the figure (219) we can see the corrugated glass covering the facades of the building. To create a large glass wall, this type of glass may not need a structure that is adjacent to it and supports it. It can bear weights and vertical loads on it. What distinguishes this



Figure 2-19: Corrugated glass used for elevations
(Source: *architectural review: Online*)

curved glass is its ability to filter the light falling on it from the outside, transmit it and pass it in a homogeneous manner and spread more in the spaces towards the inside. The glass is insulated with two coatings, solar control coating and low-e coating, in order to maintain an

indoor temperature of 20°C and control the temperature outside the building, which reaches approximately 45°C . A flat glass sheet with specific dimensions is placed on top of a three-dimensional mold that is resistant to high temperatures, then it is heated at a temperature equivalent to 800 degrees Celsius and takes the shape of the mold under it, and then it is cooled, after which it takes the curved and corrugated shape of it.

2.2.7 Air conditioning and lighting systems

Through the aluminum panels that make up the ceiling, we find what is interspersed with lighting units spread over the entire ceiling and air conditioning systems in addition to sprinkler system as shown in figure (2-20).



Figure 2-20: Lighting and conditioning systems. (Source: architectural review: Online)

2.2.8 Landscaping

The idea of simplification in dealing with the surroundings of the library was proposed, in view of the difference in what we see in the city plan and what goes on around the library building from the irregular diversity of the forms used for parks and other buildings.

According to figure (2-21) there is a group of circles of different sizes and depths have left many drought-tolerant plants planted in them, especially in this environment, such as acacia, agave and Euphorbia. [16]

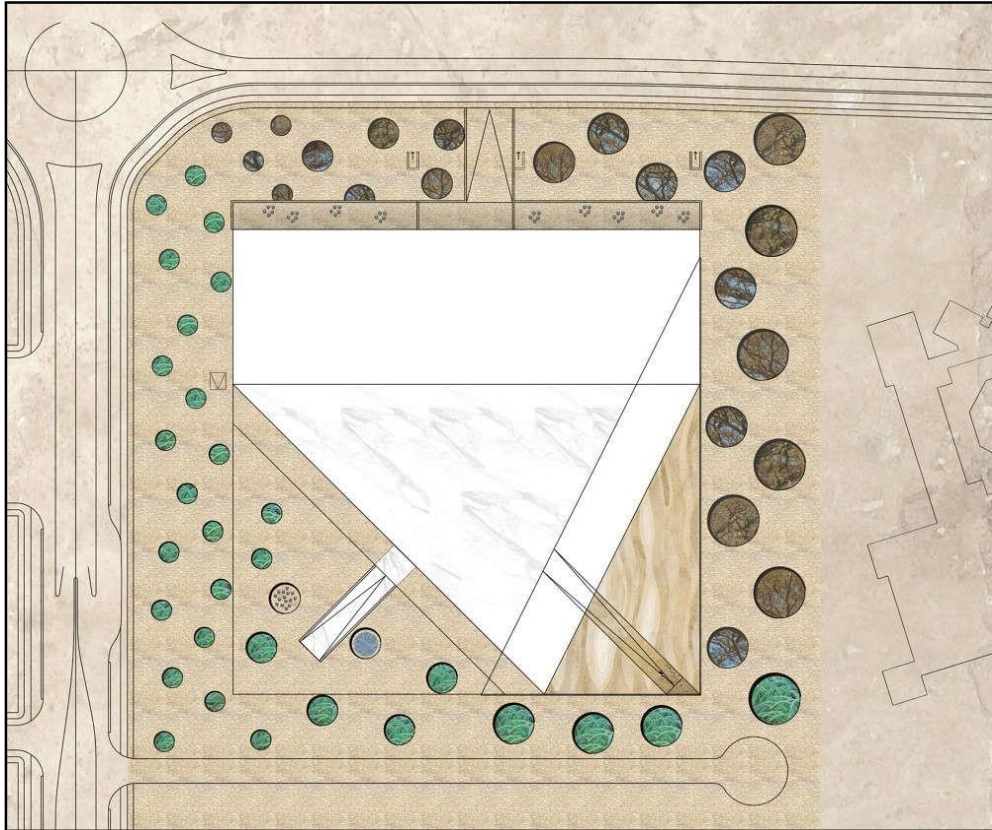

Figure 2-21: Variety of agricultural circles on site. (Source: architectural review: Online)

You may see yourself walking on a limestone deck on the garden floor cut into jagged, oblong blocks embedded in the sand between planting circles as shown in figure (2-22).



Figure 2-22: Limestone deck on the garden floor (Source: architectural review:

Chapter 3 Project Program

The main goal of every library, no matter what its type and size is to satisfy the information needs of its patrons. All of a library's operations, including resource selection, organization, storage, and distribution, carried conducted with consideration for the needs of the users. Libraries must evaluate their services. They must determine if the services being offered are suitable for the needs of the users, reaching the target audience, and users' perceptions of the services. Libraries routinely conduct user studies for this reason.

3.1 Functional Requirements

3.1.1 Library spaces

- Main Public spaces
- Main service area
- Borrowing and return station
- Automated delivery book station
- Reading areas
- Digital reading spaces
- Children library
- Assistive technology area
- Studying area
- ICT training labs
- Library digital museum
- Administration
- Smart conference room
- Multipurpose-hall

- Staff areas
- Makerspaces
- Library café
- Library Archive
- Public services

Public spaces

- Entrance/lobby: It provides visitors with access to the library, and it must be spacious and beautiful from an architectural point of view, and its area should not be less than 25 square meters.
- Rest area
- Baggage deposit: A small corner where the pioneers put their bags.
- Reception area: An area to receive visitors and an area for inquiries.
- Security: An electronic or manual system whose aim is to maintain order and control the visitors entering and leaving, and its area is not less than 15 square meters.

Main service area

Readers Services Area: It concerns the sites from which employees provide certain basic services, such as **support staff** who controlling the lending of materials Office and supervising the activities of readers and security, the location of this job is referred to as the counter or service office. The size largely depends on the user's borrowing system .The **curved counter** is the most suitable for this kind of task.

Borrowing and return station books the lending department, especially in smart libraries, requires the presence of sensors, RFID technology, and the necessary device for sorting, straps, belts, and a cart that receives books. This section takes an area about 50-60-meter square.

Automated Return/Sorting Systems

This automated method is the perfect way to receive and manage a lot of return books without having to use any physical labor. It saves the library a ton of time and hassle.

Users of the Automated Book Return System may return books whenever they choose through selfservice activities. There are three components to it: (2) a conveyor and sorting system with monitoring system that can recognize, categorize, and transfer the books to different sorting ports. (1) a wall-mounted book return machine with an operation screen and book drop entry for the user

to manage book returns. (3) carts for collecting *Singapore: Online*).

returned books that have been categorized to small movable carts that include books, and the employee applies them to the places of bookshelves. The process can be followed through figure (3-1).

While the conveyor and sorting system with return carts are housed within a room, the book return machine is installed outside. The returned books are detected, categorized using preprogrammed groups, and then delivered to the appropriate sorting ports.

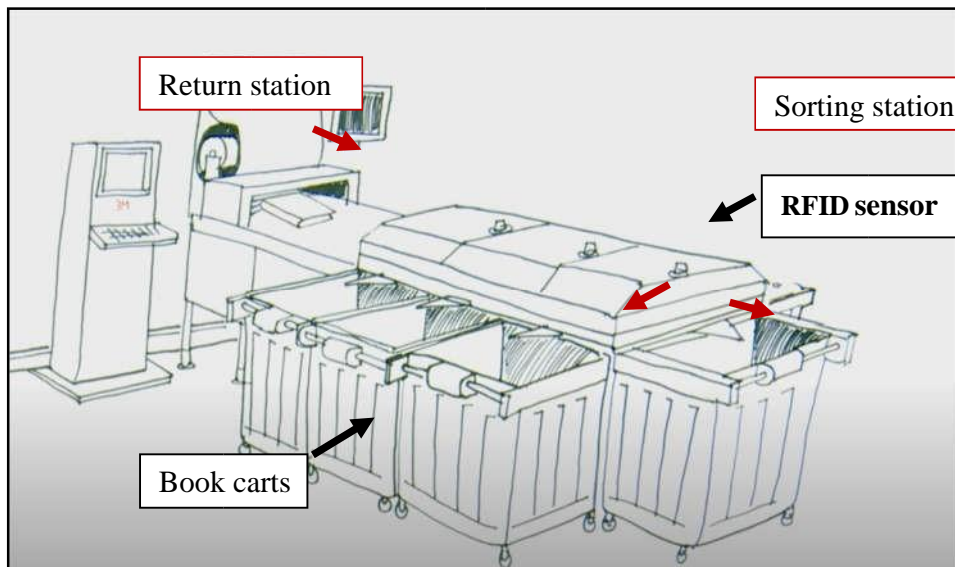

Figure 3-1: Bookshelves module dimensions. (Source: Godrej Group Singapore: Online).

Automated delivery books System:

The most exciting new feature in smart library is probably the bookbot as shown in figure (3-2), a robotic book-delivery system that will automatically retrieve books for users once they select them from a virtual catalog. The books will be stored in large number of underground bins , in high-density shelving units that can hold about 2 million volumes in one –ninth the space of normal shelves .

Within minutes of receiving a request ,one of the bookbot’s robotic cranes retrieves the requested material and delivers it to an operator , who sends it on to the library service center .That kind of technology has been used in manufacturing for years , but it’s finally entering the world of research libraries . Viewers can even watch the operation of getting books at library.

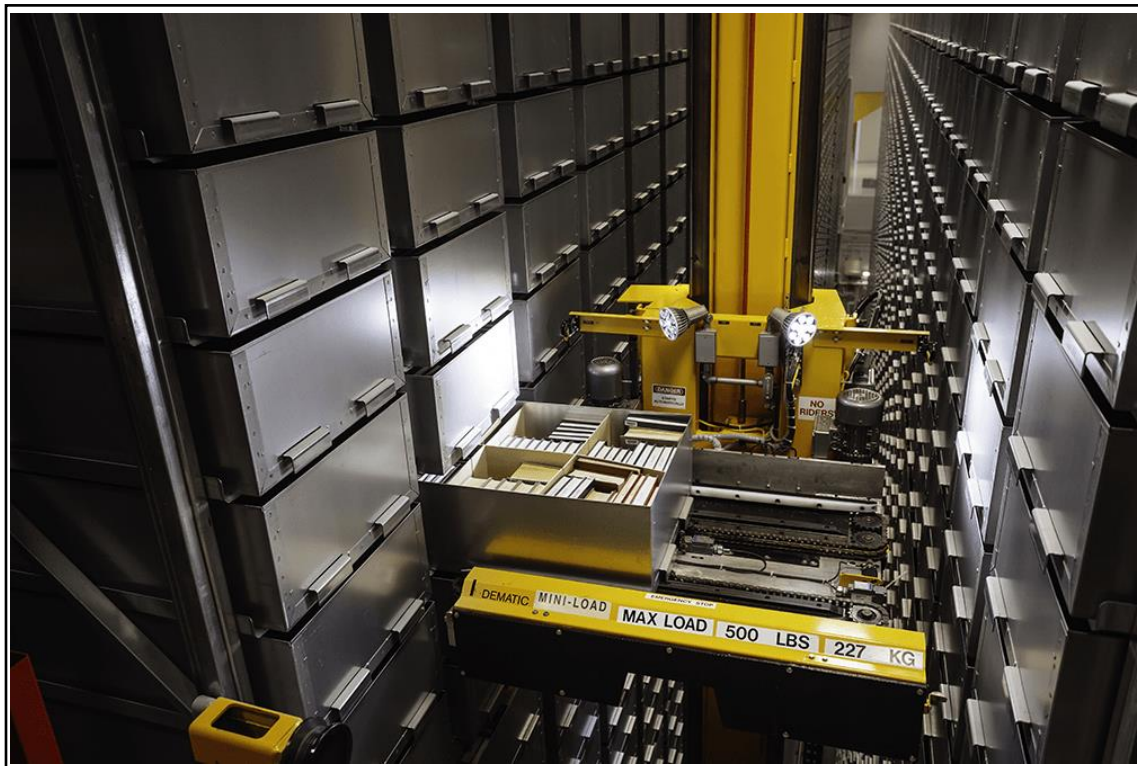

Figure 3-2: Bookbot at hunt library.

Reading area

The size and area of reading rooms varies with the number of readers, come from the equation 3 seats for each 1000 inhabitants. And there should be 6 seats at each reading table. The library will include Nablus Governorate so for reading area the numbers of readers equal 300 reader. So, the specific area of these area about 600 meter square. The space for a single workplace equal 2.5 sq. meter Minimum and the minimum spacing between tables equal 0.6 meter according to figure (3-3). This figure shows also the dimensions of reading table.

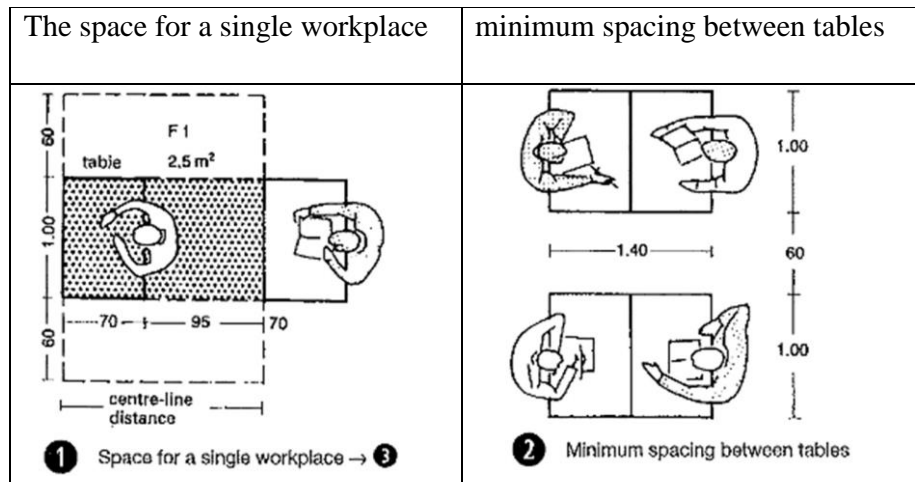

Figure 3-3 :area for single work place and the minimum space between tables. (Source: firasf blog personal website)

Bookshelves area

Readers need a bookshelf area so that they can take books from them and read them in their own reading area, and it must be close to them for ease of using books and returning them for the bookshelves area there are standards that must be considered and the total area needed about 150-meter square. The minimum space between each stack is 1.3 meter and to have a space for people how are walking and standing and for moving campers you need to leave space about 3 meters as shown in figure (3-4)

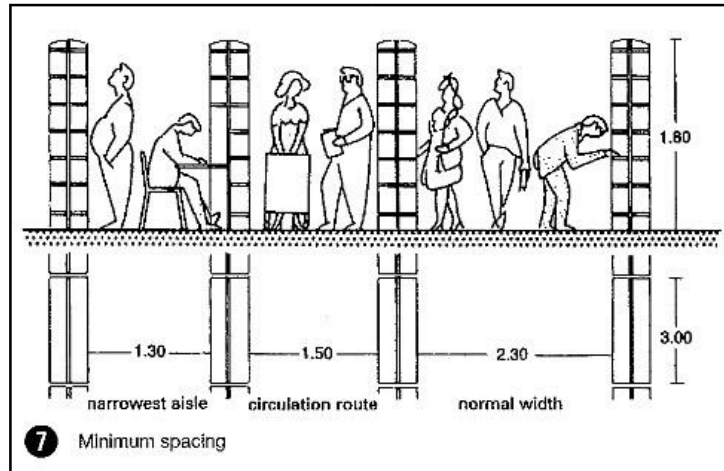

Figure 3-4: Space between each stack.area for single work place and the minimum space between tables. (Source: firasf blog, personal website)

Digital spaces

In modern and smart libraries, there are digital and electronic reading units, i.e. e-books, which are stored in devices such as touch screens or digital newspaper and computers.

- **Digital Periodicals:** □ **Digital News paper**
- **Computer zone:**

The computer hall contains computer units that are spread throughout the hall and are equipped with special headphones for each device, and each device contains a database that includes ebooks, some of which are built-in with sound, so the noise inside the hall must be overcome

and calmness must be maintained as shown in figure (3-5).the total area comes about 120 meter square include 40-45 computer device.



Figure 3-5: Computer hall at digital reading hall. (Source: Google Photos)

□ **U-touch interactive tables:**

Smart libraries have tables with large touch screens that can accommodate 20 simultaneous touches without problems. Pressure-sensitive dots and high tracking speed allow quick touch detection for quick drawing and writing without the need for an active pen, plus new app gestures for music, games, e-books, and smart user interfaces. It will be required about 6 touch tables, 4-6 people maximum stand at each table so the total area needed for 24 people is 60meter square. The figure (3-6) shows the u-touch interactive touch table.



Figure 3-6: U-touch interactive touch table zone. (Source: Utouch website: Online) .

- **Media walls:**

Similar to a reception desk, media walls are situated at the library's entrance to greet guests according to figure (3-7). The Media Walls are an effective technique for communicating with:

- A tool for promoting occasions, library holdings, books, authors, etc.
- A media teaser that reveals several media themes.
- Encouraging both young and old to explore relevant library resources.
- Entertainment provided through games and leisure-related software.
- In-library live broadcasting of events.
- Available custom data based on visitor.



Figure 3-7: media walls are situated at the library's entrance to greet guests. (Source: Indiamart website: Online)

Digital totems:

It is a free-standing, one-sided digital advertising board that supports both image slideshows and videos—with or without sound—giving your messages a contemporary look and assisting them in standing out. To make moving around your business easier when needed, add braking wheels to the base of your device.

The following features are included in the content, which has been specially designed for use with library services and applications:

- Passive Mode (incl. Events, News, Authors, Videos, Choreography, etc.)
- Two Main Menu (Home, Language, Magnifier, Tutorial).
- Three. Content Browser (Public Catalogue Books, Authors, News, Articles, etc.).
- 3-D Way Finding Map, video, pictures, calendar also games and drawing software.

Standards of digital totems

The thickness of these totems is about 0.45 meters, and their height ranges from 1.8 meters to 2 meter and the figure (3-8). shows us the specific dimensions of the digital totems.

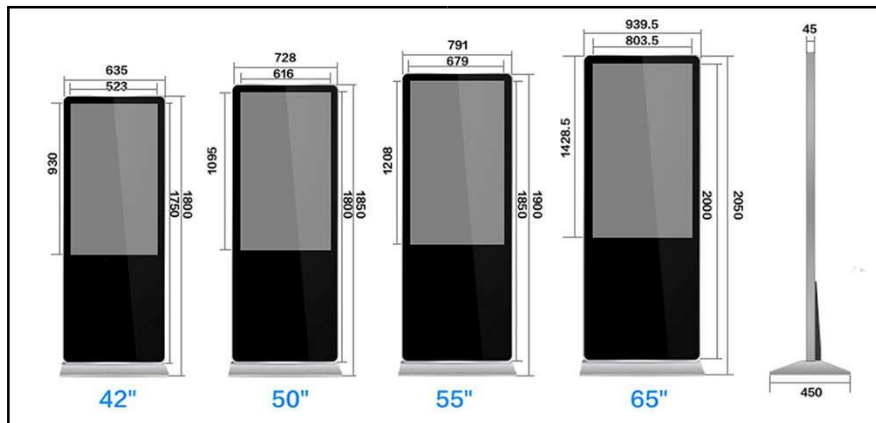

Figure 3-8: Standard dimensions of digital totems. (Source: Itatouch Website: Online)

- **Wayfinding kiosk:**

These wayfinding kiosks offer library guests helpful data and creative direction within the Library. The kiosks have been placed in key areas with expansive views of the event. Users can view POI that are presented over the live video stream of the surrounding landscape via augmented reality. Touch a POI to find out more and sort them into different categories as shown in figure (3-9). While the figure (3-10). represents the specified dimensions and explains the shape of these kiosks.



Figure 3-9: Wayfinding kiosks offer helpful data. (Source: *Phygital Experiences - Qatar National*

Library, Online)

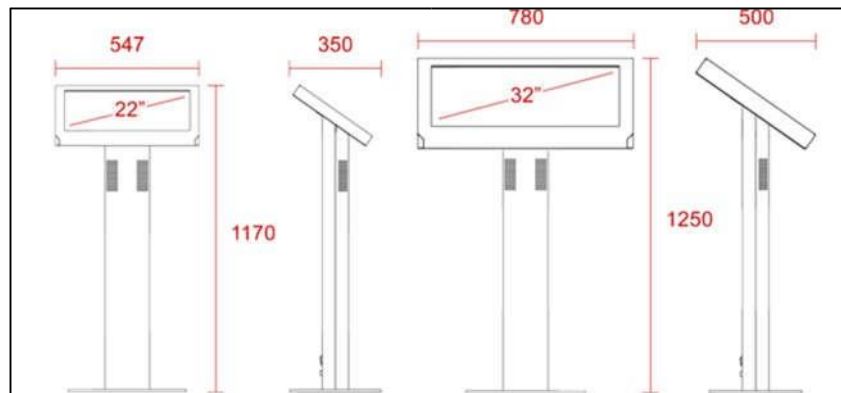

Figure 3-10: specified dimensions of the Wayfinding kiosks. (Source: *bscenclosures website,*

Online)

Children Library

Considering that we can classify this category from infants to 11 years old. children need a large section for them that fulfills what they need, whether from the reading area or the play area and activities, in addition to the innovation and creativity area. The library serves about 100 children and the total area needed about 160-meter square.

- Reading area:

The reading area varies in seat sizes and shapes, and this is due to the age group that uses it, so we will see the necessary dimensions for each age group from the height of the seat and

the table as shown in figure (3-11). The total area needed about 200-meter square for 100 children.

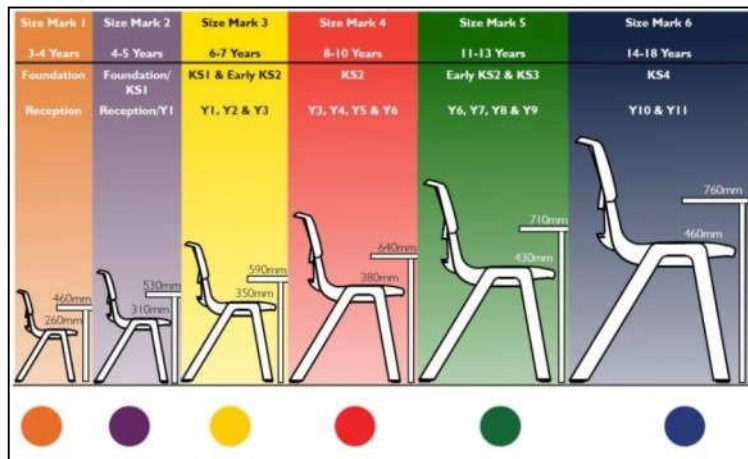

Figure 3-11: height of the seat and the table according to age group. (Source: Chair & Table Sizing

Guide, kieurope website: Online)

- Bookshelves area:

It must be considered that the dimensions of the bookshelves are reduced in size to suit this young age group, and perhaps make their shape a lively form and in harmony with the reading seats, adding more interaction for the children and making them a unified point for them. Among the design considerations in making the bookshelf units, we will take the number of shelves from 4 to 5 shelves for a group of children the space needed for bookshelves about 30meter square. as shown in figure (3-12). and each What suits his age, as we can see in the figure (3-13).

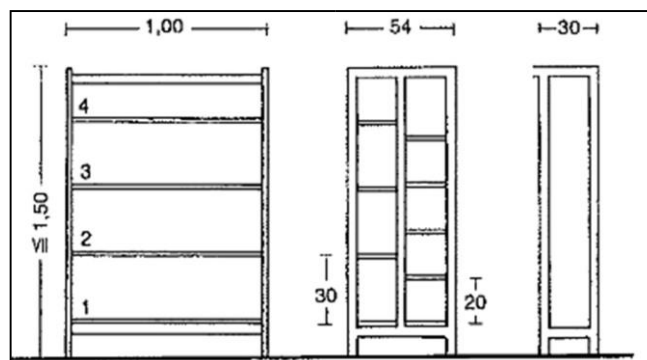

Figure 3-12: (4-5) shelves for a group of children. (Source: Living house website: Online)

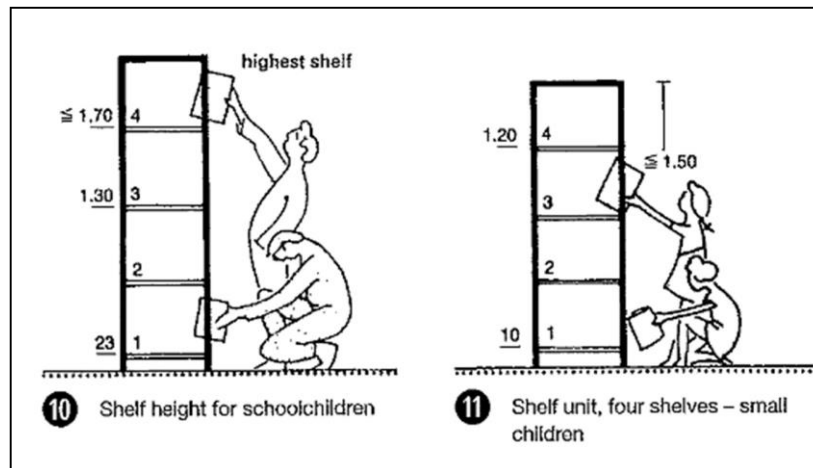

Figure 3-13: *Shelf height for childrens.* (Source: *Living house website: Online*)

- **Playing area:**

Children, wherever they are, always want to have a bit of luxury and play. It is necessary to allocate a space for children to have fun, and there are some games that encourage more learning and add a spirit of challenge to them and the total area of playing zone equal 30-meter square.

Assistive technology area

The Public Library Offers Assistive Devices for the Visually Impaired The Public Library offers devices that speak printed words, enlarge computer screen text, and display enlarged printed items (books and periodicals) on a special video screen for library patrons with visual impairments. On a computer in the Tech Center, the Library has text-enlarging software (ZoomText) mounted. Priority use of this computer, which is situated on a wheelchairaccessible table that is completely adjustable, will be given to users with visual impairments. In general, people with special needs who suffer from visual or movement problems may open the way to a room that can accommodate 12 people, and considering the area of movement and corridors, it comes as 150 square meters minimum.

The library receives a number of students, whether university students or school students, and they belong more to places that allow them calmness to complete their tasks and studies. The library provides them with a corner of their own, and they may need multimedia rooms or computer laboratories to complete their homework, solve their problems, or study electronically.

Studying area

It includes the following:

- **Quiet study room:**

Students usually adopt a quiet room designated for study, and this room requires chairs and tables, either double or single. The minimum number of tables 10 tables each table should have 3 seats minimum Considering the dimensions between tables and movement corridors so the total area about 50-meter square.

- **Group study room**

There are common study rooms dedicated to a specific group within a closed space that contains one table for four seats or four participants and sometimes it shall be equipped with a screen or a computer, each room has an area about 10-meter square and we need 4 rooms so we need about 40-meter square for this space.

- **Study carrels**

These carrels give more privacy in the study, and their size is suitable for the space of each individual , also And it is equipped with custom lighting for each person .The carrels are repeated, so they give the shape of the row, and the repetition of this row gives it the form of rows which is illustrated by figure (3-14).The type that we recalled is the unlocked double type and has specific dimensions of area for each individual which equal 0.75 meter square , as in figure (3-15).



□

Figure 3-14: Double Study carrels area for each individual. . (Source: Living house website: Online)

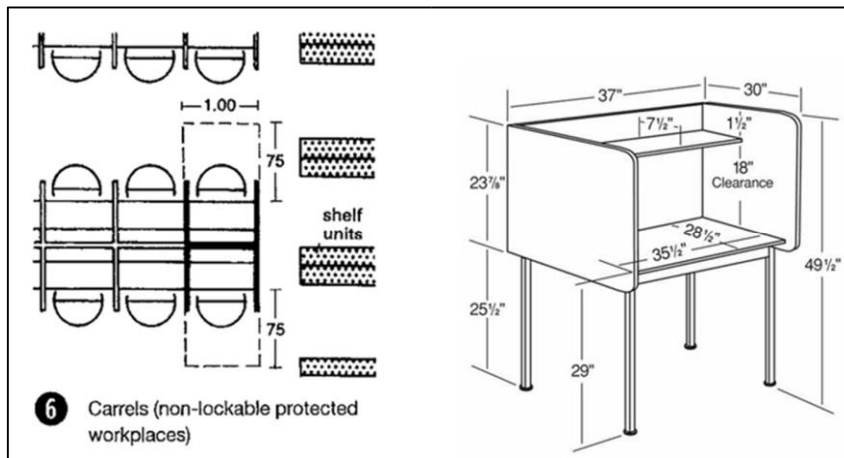

□

Figure 3-15: Double study carrels area for each individual

- **Computer lab**

We need a computer lab room at least 20 computers, meaning we need 20 seats to be arranged in the form of tables in horizontal rows, considering the distances for movement between them. If 7 computers carrels are distributed in each row, we get 3 rows so the total area needed 50meter square.

ICT training labs

ICT training room called Computer Lab or Training Room Ceiling mounted projector, screen, VGA/HDMI and VIA connections, speakers, 4 Flat Screen monitors on the side walls

and computers for training. The needed area equal 80 meter square contain 30 computers.

Figure

(3-16). Shows the ICT training computer.



Figure 3-16: *Computers above the tables in the Ict training room. (Source: washington university school of medicine in st. louis: Online)*

The computers can be lowered into the tables with the push of a button to make flat surface, training tables if computers are not needed for training as in Figure (3-17).



Figure 3-17: *Computers been lowered into the tables. (Source: washington university school of medicine in st. louis: Online)*

Library digital museum As using technology in library, we can also use it to review valuable and historical books and some maps in an interactive way and encourage the public to respond to this museum by showing digital interfaces and displaying maps digital. Through the use of artificial intelligence as in figure (3-18)



Figure 3-18: Using (AI) in library museum. (Source: The nation Thailand, 2019: Online)

The method used to preserve them is vertical treasuries ranging from 1-1.5 square meters in height, 0.95-0.9 square meters in width, and 0.43 square meters in depth. The maps are displayed on the walls. As for the smart way, it becomes a digital map that can be enlarged and reduced, and you can identify its details. The area of this section is 85 square meters. as in figure (3-19).

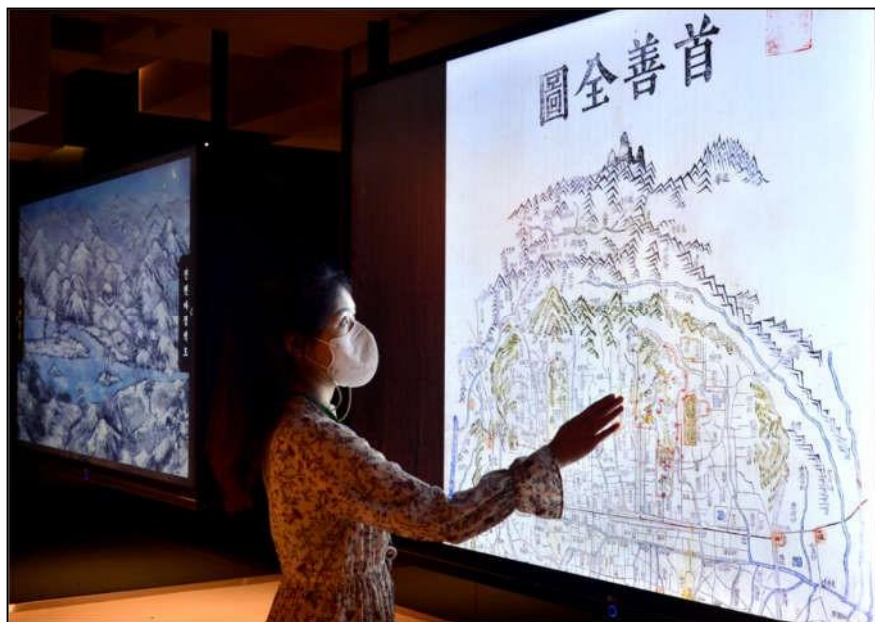

Figure 3-19: Digital map used in library museum. (Source: The nation Thailand, 2019: Online)

Historical holdings section

Old newspapers and historical books are read in it, films about history and local heritage are shown, and with the presence of augmented reality techniques, you can get them interactively, and its area is 35 square meters.

Periodicals section

This section is considered one of the important sections in specialized libraries that depend on meeting the demand and needs of researchers and the latest knowledge in the field of specialization. There must be a set of tables for reading with an area of 0.6-0.8 square meters per person, considering the movement distances between the rows of tables within 1.9 square meters.

Administration

The manager's job is to formulation of plans, policies, and decisions. he establishes guidelines for how a library should run, maintain order, and enforce discipline there. There is also a deputy director in the room next to him who is acting on his behalf.

Each of the director and his deputy needs an office in which he performs his duties, and in each office, there is a work desk and some cabinets and shelves and the needed area for the manager is 25-meter square and his deputy 20 meter and for the secretary 15-meter square.

Smart conference room

There should be a meeting room in the library building to discuss some important library matters and this meeting room area differ by the numbers of seats and the size of table. And the number of members equal 25 so the total area comes about 40-meter square. The system of this room is variable with the effectiveness of technology. You can change the position of the room in any position you want, in the operating mode, for example, with a device that controls all the devices inside the room, whether it is turned on or off.as shown in figure (3-20).



Figure 3-20: *Smart conference room, Saudi Arabia. (Source: MegaTech, 2020: Online)*

For example, if we take the size of (610*365) cm There are some design criteria that we consider Allocate roughly the following space around the conference table so that people can move around it easily:

- When placing the seats around the meeting table, leave 65 to 80 cm minimum/maximum between each chair.
- Meeting table to wall distance should be between 110 and 140.
- 40cm minimum between back of chair (when pushed-in) and the wall.
- 50-70 cm must separate the chair's back from the wall for you to be able to walk straight ahead.

According to figure (3-21). We can understand the above based on the dimensions specified in the figure.

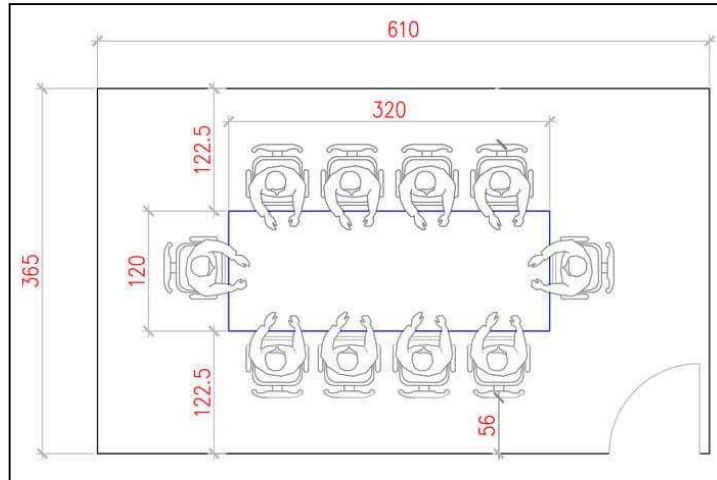

Figure 3-21: Conference room dimensions. (Source: ID Workspace, 2020: Online) Multipurpose hall

The library provides a multi-purpose room that can be used for different purposes, such as Reading a story to children - a room for watching movies and videos - a room for meetings and seminars - a computer room - a training room. The size of this hall varies according to the number of people present in it, and the area of needed be calculated through: square footage needed in the meeting room equals the number of seats multiplied by 10. The number of seats equal 150 so the total area about 180-200 meter square.

Layout of multipurpose hall

According to figure (3-22) we understand the arrangement of seats and the room sometimes provided with stage, it requires a display Screen and a good lighting. The minimum space between rows of seats from the head of the front seat to the head of the rear seat is at least 0.9 meter.

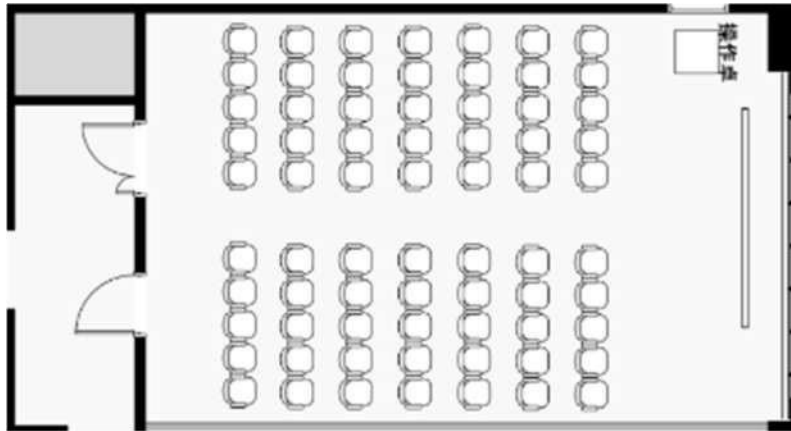

Figure 3-22: arrangement of seats through multipurpose hall. (Source: Salisbury University website: Online)

Staff area

Employees need spaces in which to perform their duties inside the library. These spaces and areas vary according to jobs in terms of their size and the number of employees, equipment and materials that meet their work needs. These spaces may vary into:

- 1- Offices.
- 2- Staff lounge
- 3- W.C/kitchenette

Makerspace

Modern and modern libraries have become inclined to give opportunities to their generation by presenting their creativity according to the available modern and innovative machines and teaching them to use them, experience them and benefit from them. According to figure (3-23). We understand the space of makerspaces at library. Maker spaces which also called hackerspaces provide Edmontonians with access to a range of services and tools, including recording studios, top-tier workstations for creativity, 3D printers, laser cutters, sewing machines, and more and the total area comes from 100-150-meter square.



Figure 3-23: Makerspaces in smart library. (Source: The makerspace of the Edmonton Public Library (Canada), 2019: Online) **Services & Equipment of maker space:**

3D printing

It includes a 3D printer and the associated software to control it.

Heat press:

With the help of cutting tools, you can design and cut a range of heat-press materials to create personalized apparel, accessories, and home décor.

Sewing:

With our computerized sewing machine, you may learn to sew or demonstrate your fashion design talents.

Computer software

These sophisticated devices come with both free and paid applications for modeling, graphics, game design, music, sound, and video editing

Audios -studio

Each studio has a distinct recording quality and is perfect for a variety of tasks. Each one has an iMac, an audio interface, monitors, and a keyboard MIDI controller. Customers can use a variety of instruments and other pieces of equipment at each site during their studio sessions.

Café

Among the sections of the library are resting places, such as the cafeteria, in order to add a refreshing and lively atmosphere inside the library. Readers take a long time to read or during social times, such as activities and seminars, often need an outlet for them. It is preferable that they be open and with a good view. The cafeteria includes bar seats, tables, kitchen, a cold store, and bathrooms. The space needed for each person ranges from: 1.1 - 1.2 square meters . So, the library cafeteria covers an area of about 150 square meters. The standard dimensions are illustrated in figure (3-24).

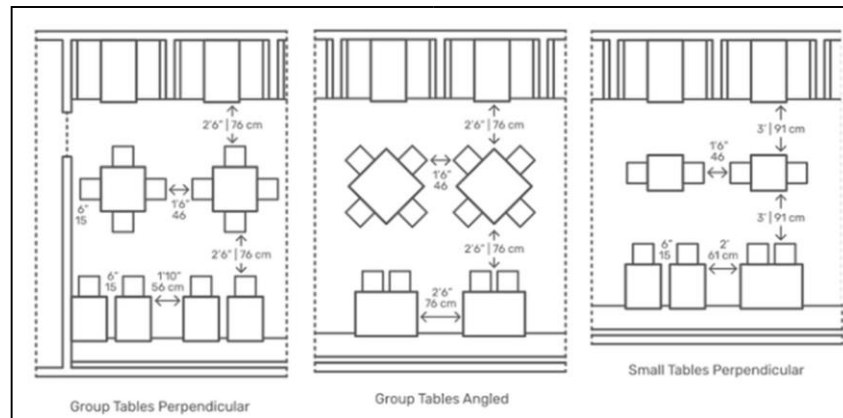

Figure 3-24: Standard dimensions of cafeteria's tables and spaces.

(Source: Dimensions website: Online)

Library Archive

- Map sections
- References section:

It includes bound newspapers, atlases, dictionaries and rare books, but screens are placed for it to make it interactive and it takes up an area of about 100 square meters.

Public services

There must be public bathrooms, units for women and others for men, and private bathrooms for people with special needs. Four units are distributed for each of the two categories, and a special unit for people with special needs.

3.1.2 Required library equipment

The library needs equipment and devices that meet the needs of its users, or, for example, the lending department, especially in smart libraries, has become easy with technology and the presence of sensors inside the library. With the existence of the smart library, especially in the historical section of books, the library makes this section an interactive section that needs to employ books in digital form by displaying clear pictures, videos and texts that clarify the concepts of these books and make you feel their events in a more interactive way.

3.1.3 Library Vehicles

In addition to bicycles, we can travel to the library by private car, public car, public bus, or school bus. Trucks may occasionally be needed for printing equipment, cleaning supplies, machineries, or other purposes.

The vehicles received by the library are classified into:

- bicycles
- cars
- buses

1.1.3.1. Bicycles:

People may use bicycles to reach the library building, and it is preferable to clarify the bicycle row areas near the entrance of the building, not specifically, but as a relationship, and there are specific dimensions for the bicycle row as in figure No. (3-25).

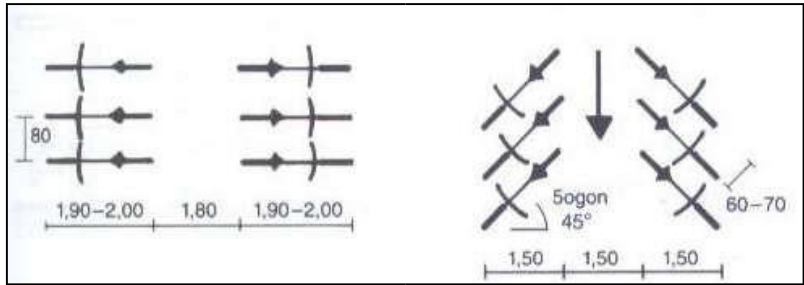

Figure 3-25: *Standard dimensions of bicycle parking. (Source: Dimensions website: Online)*

1.1.3.2. Cars:

We may not require placing the cars under the building, i.e. it is not necessary to make a leveling floor to put the parking lots, the parking lots go more to the employees' cars, and if an event takes place or important people are summoned, or there is an activity inside the library, and the parking lots are placed outside with the surrounding green areas, and the specific dimensions are calculated for car filters as shown figure No.(3-26).

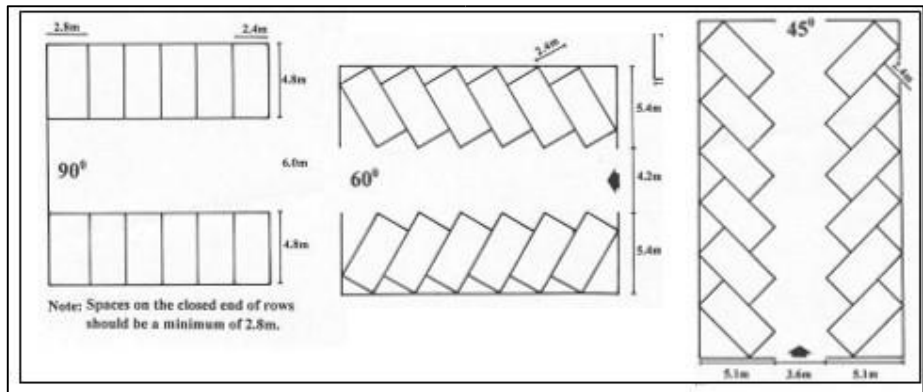

Figure 3-26: *Standard dimensions of Cars parking. (Source: municode library: Online)*

1.1.3.3. Buses:

A group of students from the school, whether children or teenagers, may come to the office, either to attend a seminar or there is an interactive activity for them, so the school bus brings them and drops them off nearby, so there must be a station for dropping off and picking up these passengers. The figure (3-27) gives the dimensions of school bus while the figure (3-28) gives the standard dimensions of school bus parking.

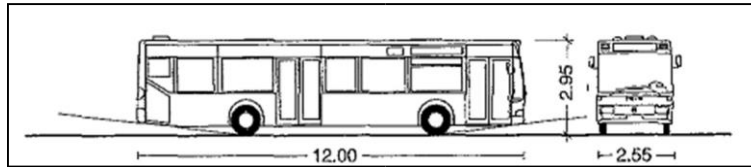

Figure 3-27: Dimensions of school bus . (Source: municode library: Online)

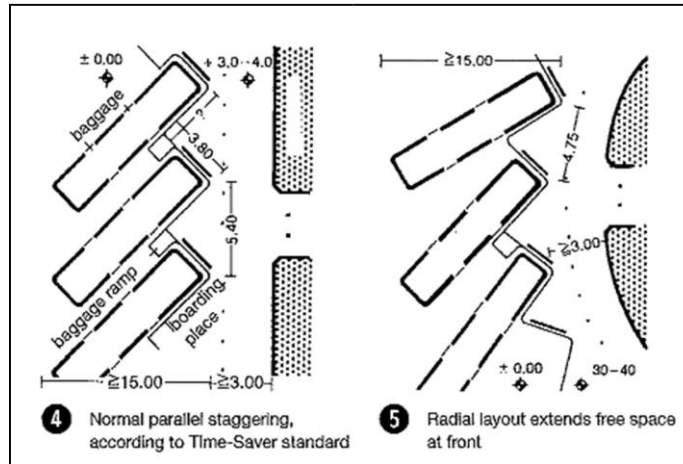

Figure 3-28: Dimensions of school bus parking. (Source: municode library: Online)

3.2 Operational Requirements

In the library, a number of components must be considered that provide a comfortable and healthy internal environment for the library. These components are:

Entrance consideration

Lighting, both natural and artificial

Ventilation

Temperature and humidity

Indicative colors

Noise reduction

Elevators and Stairs and ramps

Safety and security

Green spaces

3.2.1 Entrance considerations

The entrances to the library should be wide and attractive so as to leave a positive impact on the souls. Also, libraries need two entrances, an entrance for staff and another for loading and unloading. It considers the presence of some services near the entrance, such as inquiries and secretariats. It also considers flexibility in the doors to open and close automatically, and considers the electronic monitoring service when Entrances One of the things that must be considered when providing entrances is the provision of ramps for the disabled to facilitate the movement of their vehicles.

3.2.2 Lighting

It is one of the most important elements of the internal environment of libraries, because most of the activities that take place in libraries are directly related to the sense of sight, and the environment will not be appropriate, no matter how well it is planned and the quality of its furniture, unless its lighting is good enough.

Lighting is divided according to its sources into:

- Natural lighting
- Artificial lighting

It is also divided in terms of use into:

- Direct lighting
- Indirect lighting

Natural lighting

Natural illumination is the standard unit by which other types of illumination are measured in terms of their different sources. In view of the patrons' satisfaction with them, libraries resort to using glass facades that allow natural light to pass through the staff offices or reading spaces, given the positive impact it leaves on the psyche of the pioneers and staff, yet it negatively affects their eyes. Therefore, libraries that contain glass facades resort to keeping

them as far as possible from sunlight, and they may use several methods to avoid these negative effects.

Several methods have been used to control daylight and avoid its disadvantages, such as receiving natural lighting and distributing it directly or indirectly, while avoiding the effect of the resulting heat and the glow that it causes, and the rays emanating from it, which are a source of harm to the groups. Also, the adoption of glass facades is considered a costly means, and requires Special maintenance. As for warehouses, it is advised after exposing them to natural lighting, because they do not provide appropriate conditions for preserving documents, due to the infrared radiation that causes a rise in temperature, in addition to the ultraviolet rays that help start and activate chemical reactions and compensate them with artificial lighting for the possibility of controlling them. Neon lamps also give a dim light that is close to natural lighting. **Natural lighting considerations:**

Hence the need to study the dimensions of the windows and their location, and to avoid the drawbacks of natural lighting, which usually comes from the side windows. The lighting may be vertical if needed in the middle of the building. Natural lighting is sufficient if the area of the windows represents one-sixth of $1/6$ of the area to be illuminated, and its activity decreases as we move away from the facade to the center of the halls and becomes insufficient if the distance exceeds 6 or 8 meters, which is the distance from which it is necessary to search for other sources of lighting, to overcome On the shadows of bookcases and bookshelves caused by the side lights, Windows and façades are not only a source of illumination, because, based on the views they provide, they are considered an element of the aesthetic elements and a source of balance. Each of us is pleased to look through the windows and follow the differences in the times of the day and the succession of the seasons. Here we can say that the daylight is for the readers and not for the sake of reading.

Among the factors that are considered to overcome the limited natural lighting:

1. Making many narrow openings in the outer walls instead of few and wide openings.
2. Coordinating the colors of all green areas.
3. Avoid exposing active areas to sunlight for a long time, due to the difficulty of controlling them, and the harmful effect of ultraviolet radiation on paper and binding.
4. Do not expand the size of the windows unless they are facing east in temperate areas.

Artificial lighting

The use of fluorescent lamps in libraries is common due to the light that these lamps provide that simulates daylight, in addition to their low consumption of electrical energy. Therefore, it is suggested to maintain this type of lamps, but with the replacement of the usual structures with other structures in the form of a tube hanging from the ceiling is made of metal wires with metal or plastic strips under the lamps to distribute the lighting. It is noted that most public libraries have natural and artificial lighting, but they are It lacks a modern lighting system, as most libraries have industrial lighting overhead type (neon) At the top of the roof, which causes many problems, and we mention them, for example, difficulty reading the symbols drawn on the heels of each book, which is difficult to identify Its identity, and the lighting lacks the required aesthetic form inside the library, unlike what is present It is used in libraries.

The bottom line is that the design of lighting systems should represent 10% of the construction costs of the building. This percentage seems economically high, but the control of the internal environment and the balancing of sources Lighting (natural - industrial) inside the library buildings is beneficial to the provision of services Information It is noted that most public libraries have both natural and artificial lighting. But it lacks a modern system of lighting. The following table (3-1) shows the intensity of lighting in some spaces inside the library:

Table 3-1: The intensity of lighting in library spaces

Space	Required lighting
-------	-------------------

Reception lobby	(250-400) lux
Reading spaces	(300-350) lux
General lighting	(500-600) lux
Individual lighting	(300-400) lux
Corridors and spaces for movement	200 lux
Stairs	(100-150) lux
preservation stores	(750-1000) lux
Lecture rooms	300x

Ventilation and cooling

Library ventilation and air-conditioning requires properly ventilated areas. Proper airconditioning and ventilation are an important aspect of both reading rooms, where many visitors read, study or use computers, and library halls, where paper slowly acquires its aroma; a regular exchange of air is therefore needed. Larger libraries have specific needs for clean rooms or areas, where the required temperature and humidity levels must be carefully maintained, so the very old archived books are properly cared for and, consequently, have their lifetimes prolonged.

Air conditioning and ventilation have a major role in the effectiveness of the building and its suitability for work, especially in which is characterized by extremism in heat and cold or in humidity. And while it appears from Gaining the outcome Saying the importance of a good system of air conditioning and ventilation must be emphasized on the importance the fact that this system is easy to operate and maintain, as the origin of many air conditioning and ventilation problems many libraries resort to installing complex systems that are difficult to maintain, with a lack of skills necessary for its maintenance or repair when necessary. Artificial ventilation is combined with natural ventilation. In all cases, in order to save energy

during the two seasons of equinox, and for the necessity of natural ventilation for the holdings of the library and its employees and visitors.

3.2.3 Temperature and humidity

1- Humidity:

The humidity level that is recommended in libraries is known and must be adhered to because it has a great impact on the design. In general, the degree of relative humidity in the entire building should not be less than 30%. As for the documents and collections area rare, it ranges between 45% and 55%, as book covers can crack in the event of low humidity, or damage if the humidity is high.

2- Temperature:

Studies have shown that the best temperature suitable for reading is from 20 to 22 degrees, and the lowest temperature better for office materials, but they are not comfortable for humans, and in addition to the importance of temperature, there is great importance for the movement of air inside the voids, as it helps to reduce relative humidity and reduces the possibility of mold formation. And he has the following standards as shown in table (3-2) indicate the appropriate temperature and relative humidity in the library:

Table 3-2: The appropriate temperature and humidity for library spaces

Space	Temperature degrees centigrade	relative humidity
Reading area	20-21	30%
Archive	18-20	(45-55) %

3.2.4 Colors

Color is not just a visual effect, but its influence overlaps in the lighting component and sensation Psychological satisfaction, spaciousness of the place, etc. are influences that must be considered when recreating Employment halls of the building. It is known that the more the colors of the walls, ceilings and floors And the furniture .. and the rest of the components

of the library are not dark and tend to light colors, whenever this helps to provide Electric energy directed to the lighting, providing a sense of spaciousness, calmness and splendor It is reflected in turn on the behavior of the beneficiaries of the library, as shown in figure (3-29).



Figure 3-29: *Soft and calm colors used in the library. (Source: Archdaily, Gallery of River Center Branch Library, 2020: Online)*

3.2.5 Noise reduction

People's voices were the main source of noise in the past; has been added to it recently, other causes such as the sounds of transportation, telephone bells, and voices Printers, ready-to-copy, computers, and other devices and equipment that the library possesses noise has visible effects on the use of libraries, as this is reflected in its visitors ,there is an inverse relationship between the efficiency of the building and the level of noise in it. Although it is not possible to eliminate the noise in the library, the general character of its internal structure it should be quiet most of the time and there are traces left by noise on me the library goes, for example: the tension it causes on the nerves, the dispersion of thoughts, the lack of focus, understanding, and the performance of activities effectively.

3.2.6 Elevators and Stairs and ramps

They are available in the building if it contains more than one floor to ensure vertical movement. Stairs are subject to Some of the conditions that guarantee its effective operation, including:

- 1- The drawers are distributed in a way that enables vertical movement when necessary.
- 2- Safety systems must be provided to ensure the safety of guests and workers in the event of any emergency.
- 3- The number of degrees on one coast should not exceed 14 degrees.
- 4- Drawers must be treated and maintained so as not to allow the transmission of sounds, odors or current through the antenna.
- 5- Secondary drawers are similar to emergency drawers in terms of specifications and measurements, and their doors must open towards outside for ease of movement when any emergency occurs.
- 6- Availability of elevators to transport office materials, beneficiaries, employees and the disabled.

A must for wheelchairs be able to move within the entire library. There must be an elevator. Wheelchairs or a ramp, if the library has more than one level.

3.2.7 Safety and security

Libraries and archive stores need safety and security plans to ensure staff readiness to respond to emergencies related to fires and other risks, where there must be a diversity of different security methods, especially with regard to fire, because the library contains flammable elements. It is necessary to have a complete fire department equipped with well-distributed alarms and sensors, especially in the reading hall and stores.

3.2.8 Green spaces

Green spaces have a great and effective role in adding psychological atmosphere and aesthetic style. It attracts visitors to the library. It is important to provide an area per person of 1.2 square meters of green space.

Project program

The area of each void and its scope of service were determined as shown in the following tables:

Table 3-3: Public Areas

Main public spaces						
Space	Area	Users	# Users	Activities	Equipment	Note
Entrance/lobby	50m2					
Baggage deposit	15m2				Shelving for bags. +bags	
Reception area	10m2					For each reception
Security	15m2	Guards /monitors	3			
Borrowing and return area	50m2	Borrowers		Borrow books andreturn borrowed books	Return and sorting machine.	RFID technology is used to scan books
Printing and supply area	25m2					
Readers Service Area	18 m2	Employees				
Rest area	100 m2	Public				
Total area=300-meter square						

Table 3-4: Administration spaces

Administration and staff spaces						
Space	Area	Users	# Users	Activities	Equipment	Note
General manager office	25m2		1		Office desk	
Deputy office	20m2		2		Office desk	
Secretary office	15m2		1		Office desk	
Smart conference room	40m2		25		Projector/ touch screens	The smart technology used.
Organization manager	20m2		1		Office desk	
Reader services manager	20m2		1		Office desk	
Technical services manager	15		1		Office desk	
Accounting	18		2		Office desk	
Staff area	150		20		Office desk /sofas	
Total area=320 meter square						

Table 3-5: Reading spaces

Reading spaces						
Space	Area	Users	# Users	Activities	Equipment	Note
Reading book hall	600m2	readers	300	Reading books	Tables and seats	
Bookshelves area	150m2				Books and bookshelves	
Private reading area	20m2	students	8		seats	
digital resources	120	Readers and researchers	40		computers	

Quiet study room	80-100m2		30-40		Tables and seats	
Group study room	40 m2		24	6 people on each room	Tables/screens	
Computer lab	50m2		20-25		Office desk	
Total area=1080 meter square						

Table 3-6: Digital areas

Digital areas						
Space	Area	Users	# Users	Activities	Equipment	Note
Digital periodicals	15m2	General public			Small screens	
Digital News paper	15 M2	General public			Small screens	
Computer zone	50 M2	General public			computers	
U-touch interactive touch table zone	60 M2	General public			Tables and seats	
Media walls space	10 M2				Digital walls	
Digital totems space	10 M2				Digital totems	
Wayfinding kiosk space	9 M2				kiosk	
Digital museum	120m2					
Total area=170-meter square						

Table 3-7: Library archive

Library archive						
Space	Area	Users	# Users	Activities	Equipment	Note

Bookbot	1200 m ²				1000000 book	
References section	100m ²	Employees and readers	12		atlases, dictionaries and rare books	
Periodicals section	100m ²	Employees and readers	12		newspapers	
Map section	85m ²	Employees and readers	10		maps	
Historical holdings section	35m ²	Employees and readers	6		Old newspapers and historical books	
Art corner	65m ²		8		large work tables	
Total area=1585 meter square						

Table 3-8: Public and cultural spaces

Public and cultural spaces						
Space	Area	Users	# Users	Activities	Equipment	Note
Multipurpose hall	(180 - 200) m ²		130		Seats /project or /screens	
ICT training room	80m ²	trainers	30		computers	Smart technology is used
makerspace	350 m ²		30	3D printing laser cutting, sewing, audio studio	Tables /machine	
Digital museum	120					
Total area=640 meter square						

Table 3-9: Children spaces

Children spaces						
Space	Area	Users	# Users	Activities	Equipment	Note
Children reading area	200m ²	children	100		Tables and seats	
Playing areaworkshop	100m ²					
Total area=300 meter square						

Table 3-10: Other spaces

Other spaces						
Space	Area	Users	# Users	Activities	Equipment	Note
Café	150 m ²	General public			Tables /seats	
Assistive technology area	100m ²	Special needs	30		Seats / /screens	
Public services	60 m ²	General public				4 units for each gender and 2 units for special needs
horizontal and vertical movement	950m ²					30% of building area
Total area=1260 meter square						

Table 3-11: Total areas

Total areas	
Space	Area

Chapter 4 Site analysis

4.1 Site selection criteria

There must be flexibility in choosing the location of the library, as the project headquarters is determined, and it is the location chosen from between several places located within the site area, considering their needs, functions and characteristics, and since the suitability of the site changes from time to time as lifestyles change, so expansion and needs must be considered future when choosing a project site. Accuracy of location selection is affected by scale the shape, the number of floors, and the location of the entrance, for example, on the exterior appearance of the building, and all these factors affect the building the use of the library, but it is not really as important as choosing the appropriate location in terms of population density and its proximity to city centers and schools.

In order to achieve the desired functions and objectives of the design a number of important matters must be considered in this field, including:

- To have a clear location, preferably in corners and at intersections, where they can be seen easily.
- The site should allow future expansion and expansion of the project.
- The entrance should allow an entrance at street level and avoid secluded sites as far as possible from people's gatherings the possibility.
- Not to be found in overcrowded urban areas or overcrowded areas.
- To provide the library with a quiet and suitable atmosphere for reading as much as possible, and at the same time, for the library to be in contact with the audience.
- It has a location that is characterized by ventilation and good natural lighting.
- To be appropriately connected to the city's internal means of transportation.

4.2 Site selection

The land for the project was chosen in the city of Nablus in Palestine. The location of the city of Nablus was chosen, which is the center of cities in the northern West Bank, and given the cultural importance of the city of Nablus, which has always been the first in the field of science and culture. Also, it contains one of the most important universities An-Najah National University.

4.3 Nablus city

4.3.1 Geographical location

The city of Nablus enjoys an important geographical location, as it is in the middle of the Palestinian highlands and the Nablus Mountains. As we can see, according to figure (4-1), which shows the location of the city of Nablus on the map of Palestine. The city of Nablus connects the north of Palestine with its south and east with its west, due to its privileged location in the center of Palestine. It is 114 km away from Amman and 69 km away from Jerusalem. It is connected to its cities and villages by a network of roads linking it with Tulkarm, Qalqilya, and Jaffa in the west, with Amman in the east, Jenin and Nazareth in the north, and Jerusalem in the south. It is located at longitude 35.16 and latitude 32.13.

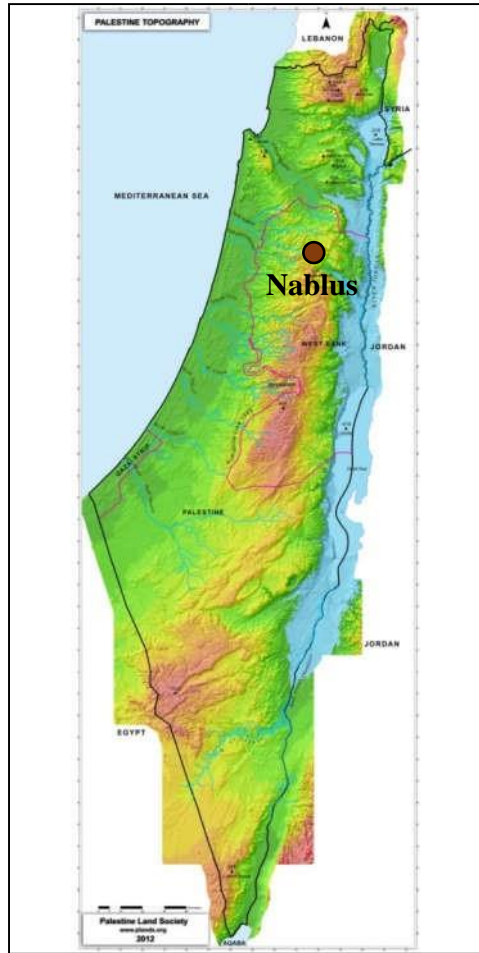

Figure 4-1: Location of the city of Nablus on the map of Palestine

The figure (4-2), shows us the current map of Nablus and the borders of the city. While The figure (4-3), also shows the street types, whether main streets or secondary streets.

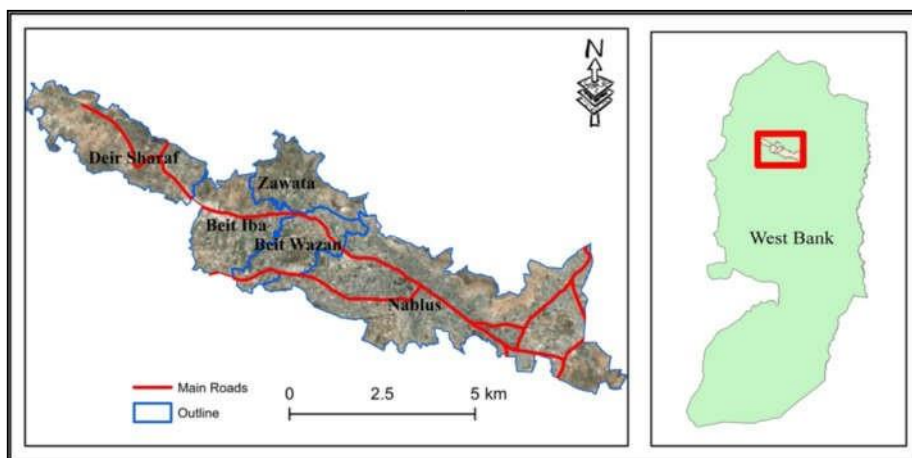

Figure 4-2: Nablus city map. (Source: *Urban Particulate Matter Hazard Mapping and Monitoring Site Selection in Nablus, Palestine*, Tawfiq Saleh and Abdelhaleem Khader, 2022; Online research)

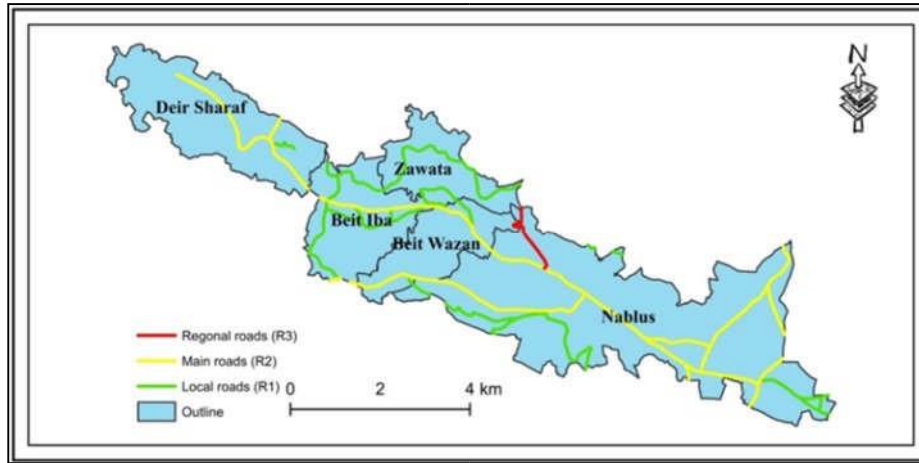

Figure 4-3: Map of Nablus illustrated with streets. (Source: *Urban Particulate Matter Hazard Mapping and Monitoring Site Selection in Nablus, Palestine*, Tawfiq Saleh and Abdelhaleem Khader, 2022: Online research)

4.3.2 Topography

Topographically, it is a valley between two mountains, with an altitude of about 220–915 m above mean sea level (AMSL) as shown in figure (4-4). A potential issue with the air quality that could have an impact on human health is brought on by the terrain of the research area mixed with several sources of air pollution. Quarries, industry, and transportation are the main causes of anthropogenic air pollution in the city of Nablus. Seasonal dust storms, which are thought to be a source of biogenic air pollution, have a significant impact on the region.

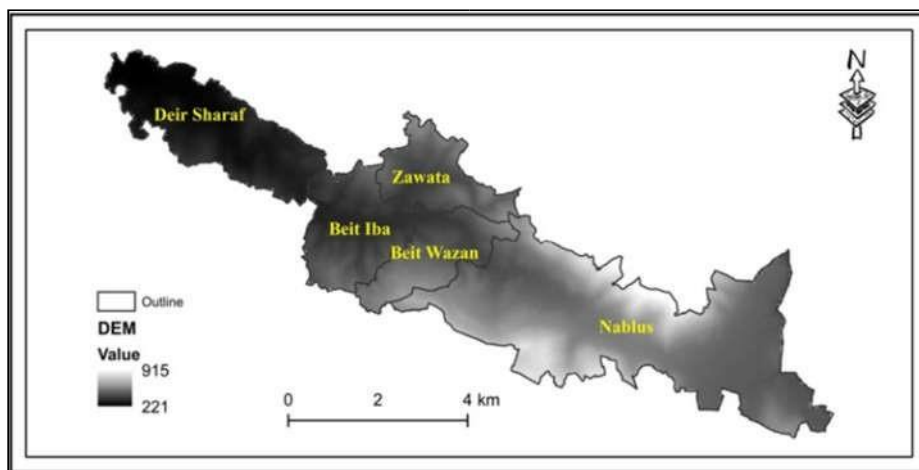

Figure 4-4: Map of Nablus and its topography. (Source: *Urban Particulate Matter Hazard Mapping and Monitoring Site Selection in Nablus, Palestine*, Tawfiq Saleh and Abdelhaleem Khader, 2022: Online research)

4.3.3 Climate

The region experiences a Mediterranean climate with hot, dry summers and warm, rainy winters. According to the Nablus Municipality, the majority of the land is used for residential, commercial, and industrial purposes, with only 3% being green space. The temperature variation in the city of Nablus throughout the course of the year is depicted in figure (4-5) the "average daily maximum" (solid red line) on the graph displays the highest temperature for an average day in Nablus for each month. The "mean daily minimum" (solid blue line) displays the average minimum temperature and allows us to consider the greatest temperature in the month of August and the lowest temperature in the month of January.

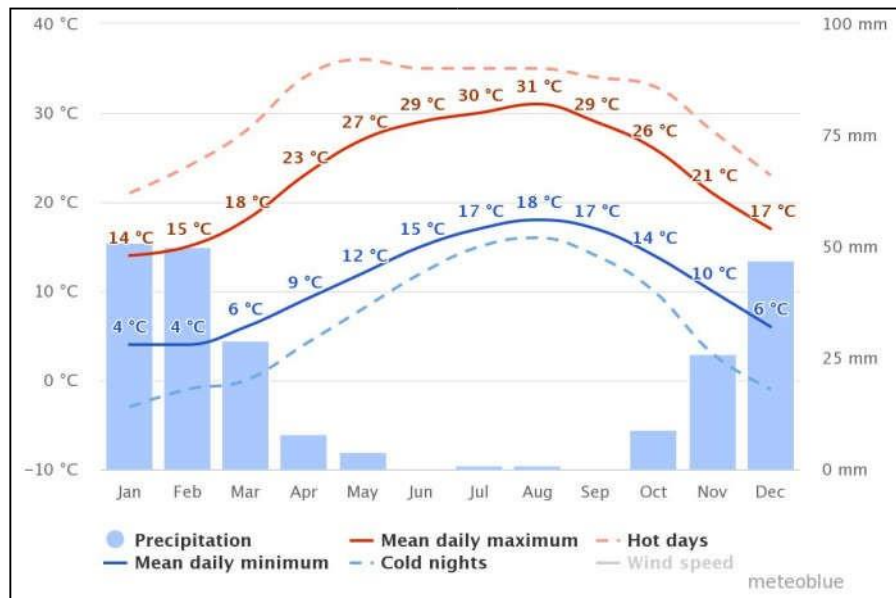

Figure 4-5: Average temperatures and precipitation of Nablus. (Source: Weather and Climate, 2023: Online)

4.3.4 Precipitation amounts

The city of Nablus receives about 660.1 mm of precipitation on a yearly average. The measurements suggest as shown in Figure (4-6) that the months of November, December, January, and February have the highest rainfall rates since it changes significantly from one month to the next

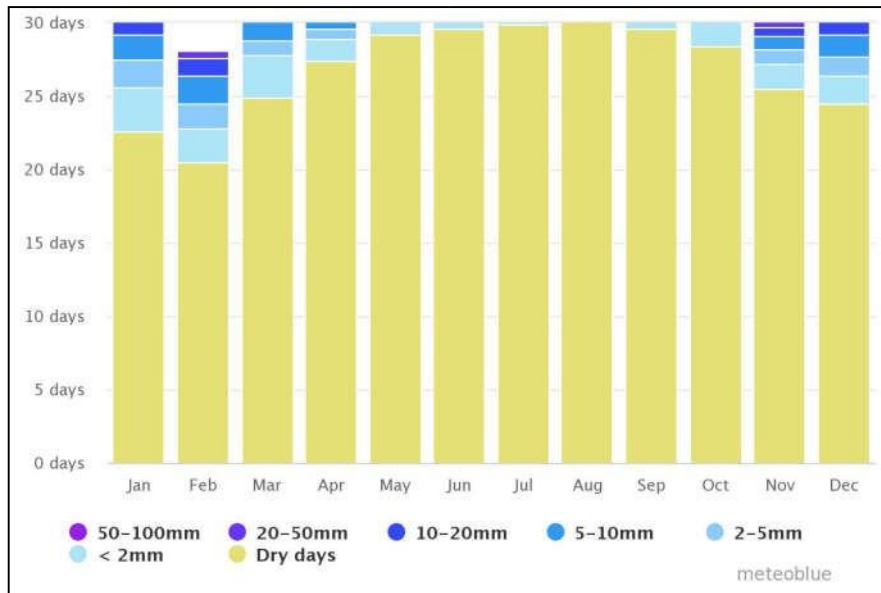

Figure 4-6: *Precipitation amounts in Nablus city. (Source: Weather and Climate, 2023: Online)*

4.3.5 Relative humidity

As for the relative humidity in Nablus Governorate, the annual general average is (61%).

4.3.6 Rainfall

For rain, as is the case in the rest of Palestine, precipitation is limited to the winter and spring seasons, specifically in the period between October and May, where the amount of precipitation annually reaches about 660.1 mm, of which 80% falls in the period between December and March.

4.4 The proposed site for the project

The land was chosen in the western region of the city of Nablus, where the western region is the most interactive these days. The land is located on the new road connecting An-Najah National University and Beit Iba, which will be a main road for the movement of students coming from outside the city, which makes it qualified to serve the largest possible number of students, and it is surrounded by a number of schools, as school and university students are the most popular group for libraries It will be easy for students, whether from inside or outside

the city, to come to the library, and the location is quiet, away from crowds, noise, and the lack of surrounding buildings and agricultural lands . It is located on the north of the new campus (AnNajah National University) on 25 street.as shown in figure (4-7).

The idea of a smart library would be distinguished from other libraries, especially that it is near the university library and that it is characterized by smart technologies that aims to make students smart and have the ability to study and analyze easily and quickly, without much time or effort with the technologies it provides them to make their time full that can be used by practicing some educational and social interactive activities within this library and this is what the library aims to produce a smart generation Keeping pace with development, creativity and exploration.



Figure 4-7: Project land near An-Najah University

 **The land**  **An Najah university.**

Accessibility

The project land is surrounded by many landmarks and the figure. (4-8) shows us how far each of these landmarks is and the time of arrival from them to the project land. It also shows the proximity of each of the educational centers and the ease of access to the project land.

And Figure. (4-9). shows the main roads and streets leading to the project land and the secondary streets surrounding the land.

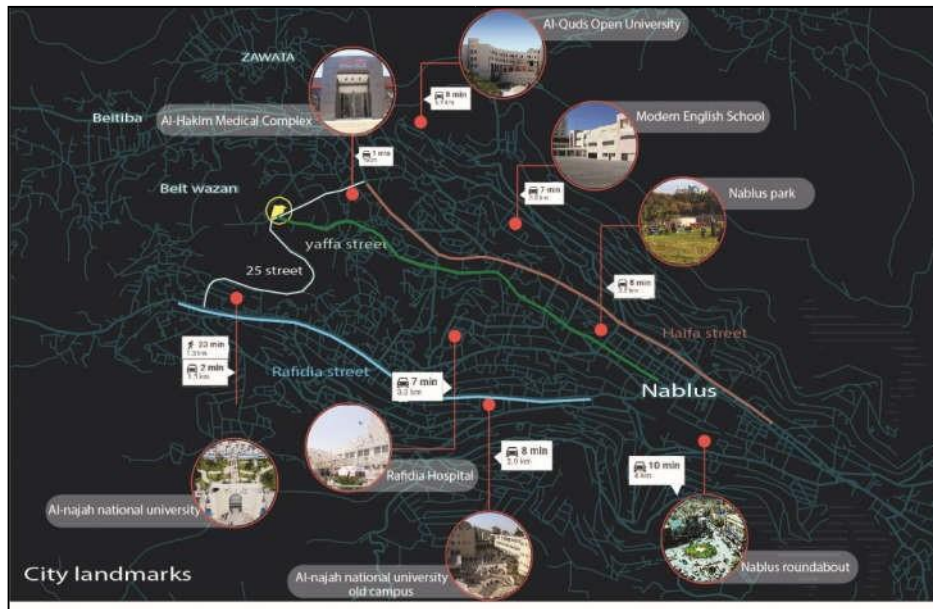

Figure 4-8:Arrival time from the landmarks surrounding the project land

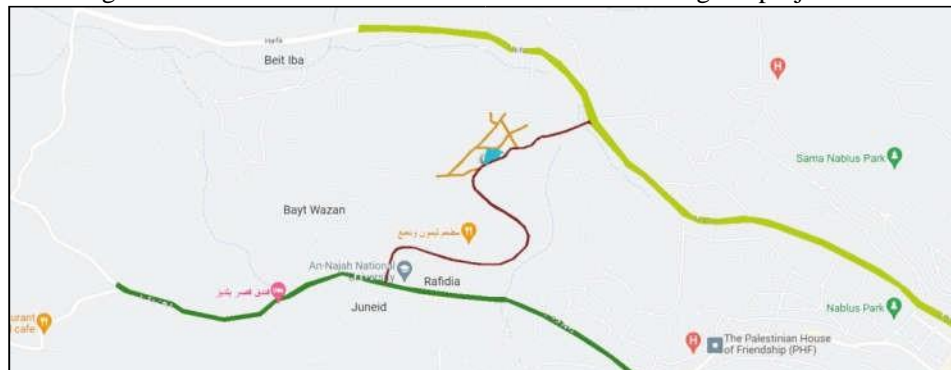

Figure 4-9:Main and secondary surrounding streets

Land use and regulations

The region's land uses can be seen according to Figure (4-10) for the proposed project land, it is designated for Residential C, according to the municipality's classification. There is a land next to it, residential B and A, and the land is surrounded by some public buildings, so we can see that the land is in a quiet area surrounding some houses and public buildings. And

through table (4-1). We can see the number of land laws according to their classification, residential C.

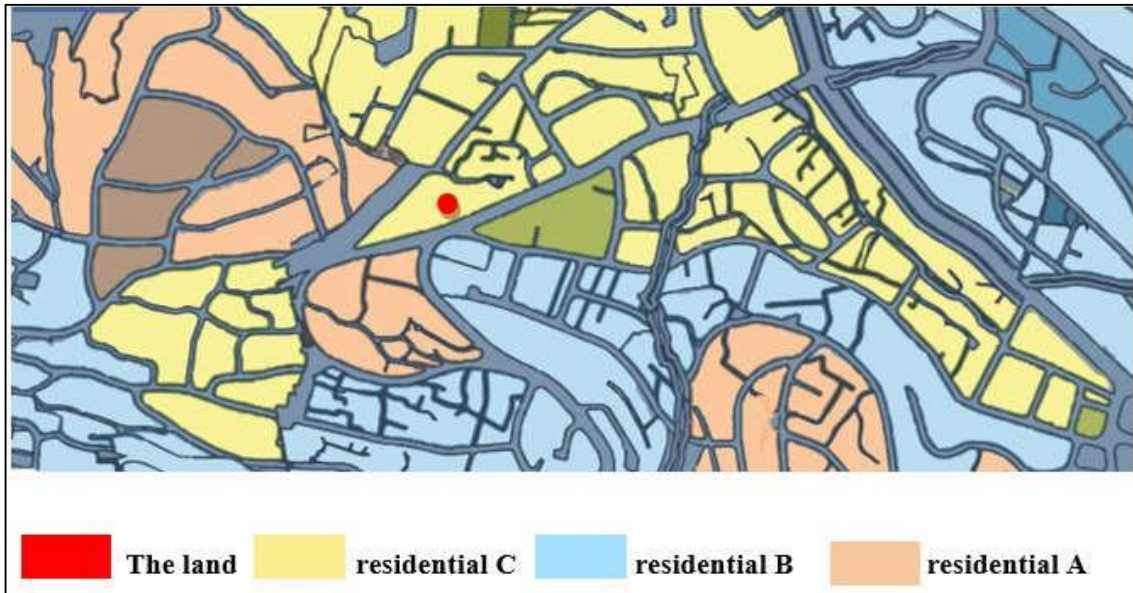

Figure 4-10: Land use and surrounding lands

Table 4-1: Land laws according to the classification residential C

Minimum			Maximum				
Bake recoil	Sideways recoil	front recoil	Building height (m)	# floor	floor ratio	building percentage	Usage class
3	4	4	18	5	240 %	%48	Residential c

Surrounding buildings

The land is surrounded by some residential and educational buildings, such as schools, in addition to mosques, some medical centers and universities, and this is what we see according to figure (4-11).

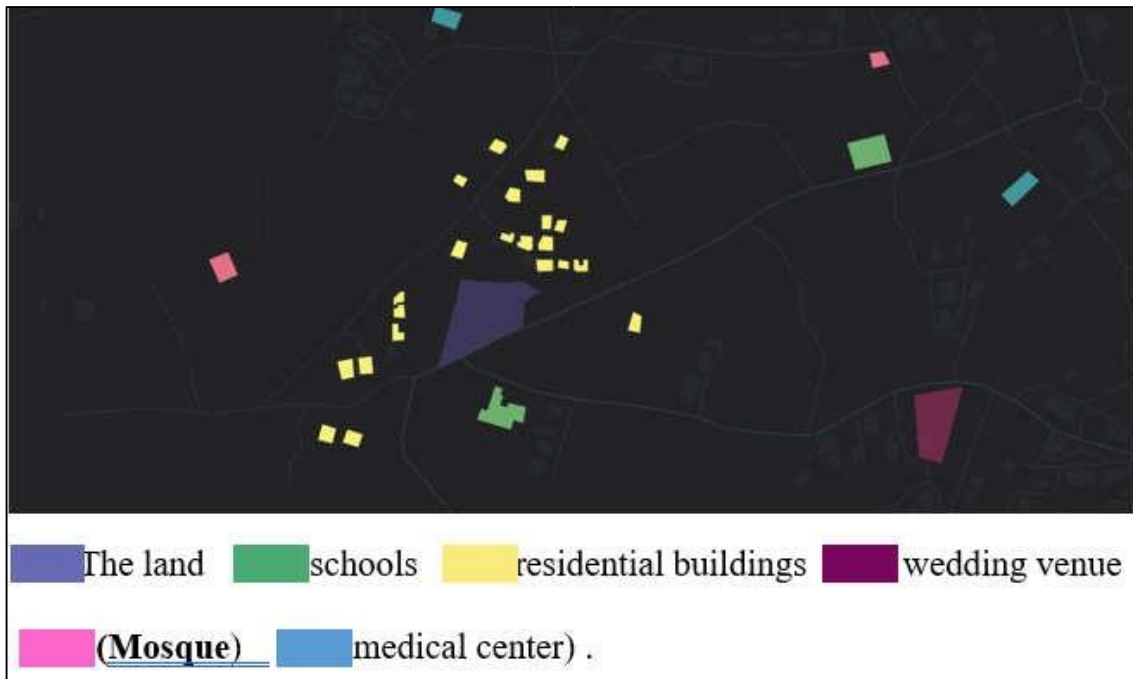

Figure 4-11: Buildings surrounding the project land

Educational centers near the site

The library is surrounded by many educational buildings, such as schools and the universities.

Where the land mediates between the two universities of Al-Quds Open University in the north and Al-Najah National University in the south, as shown in figure (4-12).

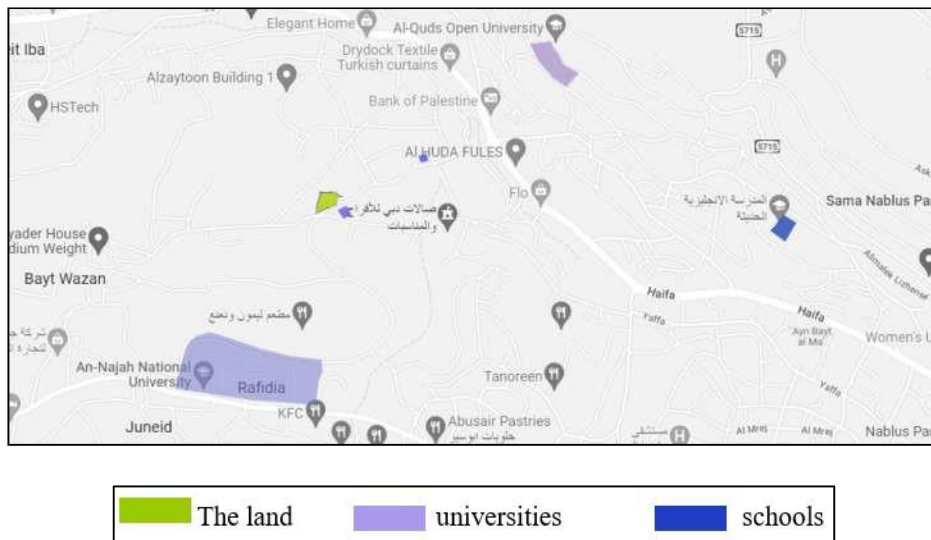

Figure 4-12: Educational centers surrounding the land

Site visual analysis

The project is surrounded by mostly empty lands and the number of buildings is small, and this makes the building more outgoing with the surrounding environment and providing a relatively calm atmosphere, in addition to the surrounding green lands full of trees, and this creates a beautiful scene. This is shown as in Figure (4-13).

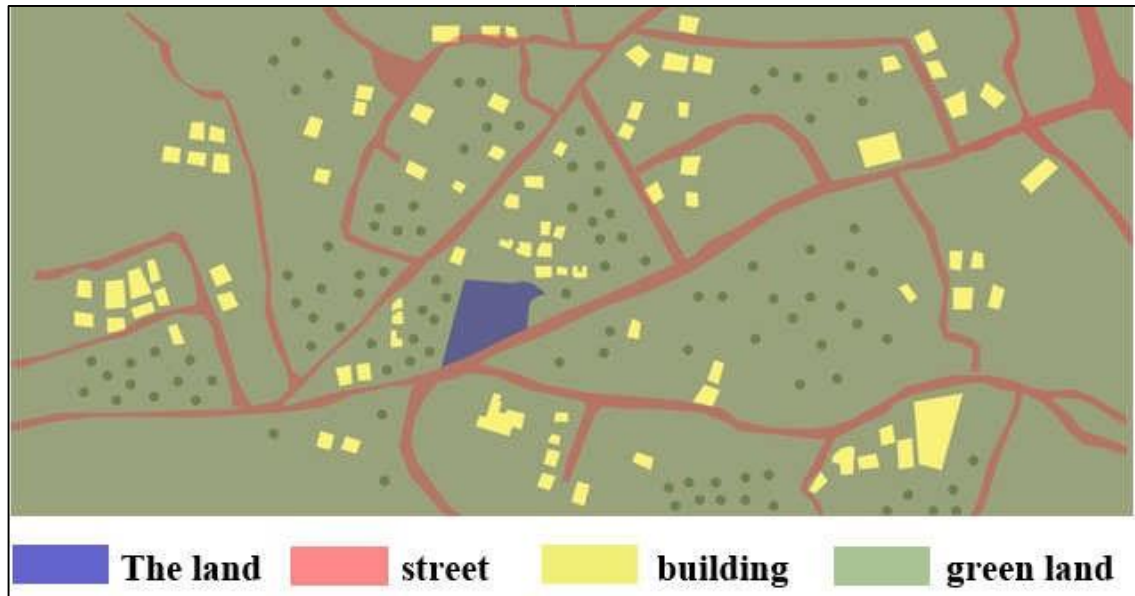

Figure 4-13: Site visual analysis

Site analysis

1- Land area:

The total area of the land comes about 6000-meter square. It is surrounded by two streets, a secondary street to the north with width 8-meter square and a main street to the south with width 16-meter square 6 plots were taken and merged into one plot.

Topography

A difference can be seen in the ground levels, where we can see 8 levels of the ground, of which 4 meters are taking up most of the land area, while at the end of the acute angle of the ground, we see the complement of the levels with a difference of 4 meters, as shown in Figure

No (4-14). From Figure No (4-15) We can see the ground's slope through section A-A, and section B-B.

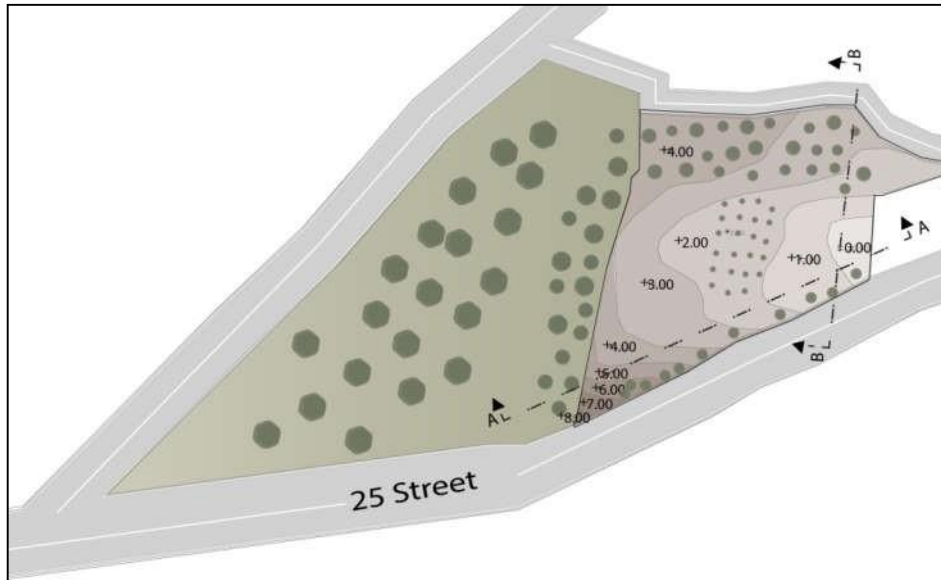

Figure 4-14: The topography of the site

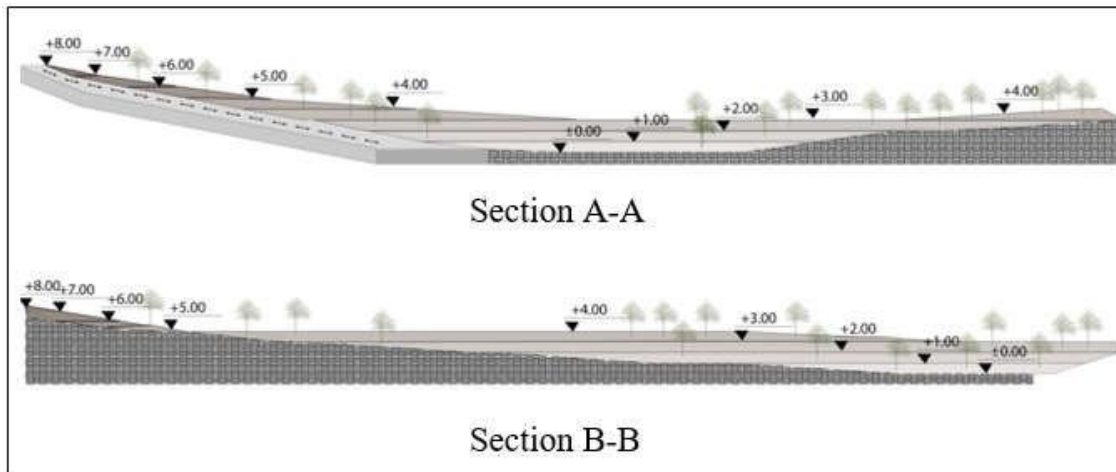

Figure 4-15: Sections showing the slope of the ground

Environmental analysis

We can analyze the site environmentally in understanding the path of the movement of the sun and the shadows coming from the surrounding buildings and studying the wind in addition to the disturbance, which is very important to study for this project.

Sun path

We can understand the path of the sun's movement in summer and winter, where we can say that the sun's rays become disturbing in the summer at the end of May. The figure (16) shows the path of the sun's movement at twelve o'clock, when the sun is vertical, while the figure (17) shows the relationship between the azimuth angle and the elevation according to this time.

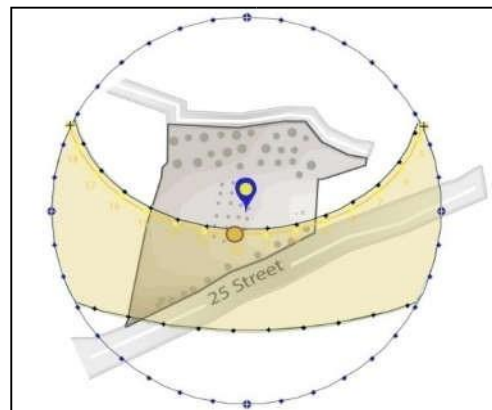

Figure 4-16: Sun path in summer

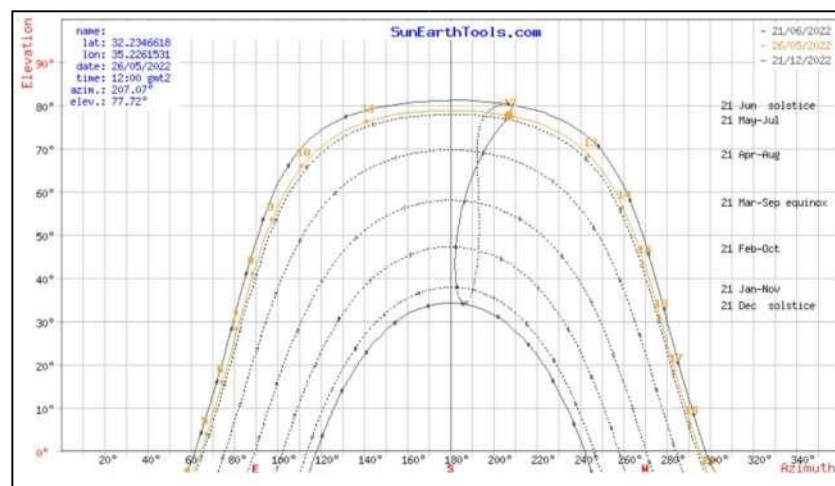

Figure 4-17: Relation between the azimuth angle and the elevation in summer

The figure (4-18) shows the path of the sun's movement in the winter in the second half of February. while the figure (4-19) shows the relationship between the azimuth angle and the elevation in winter.

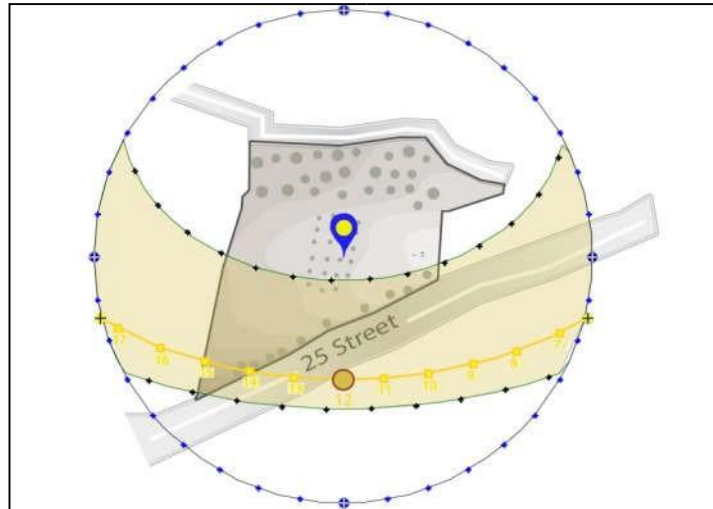

Figure 4-18: Sun path in winter

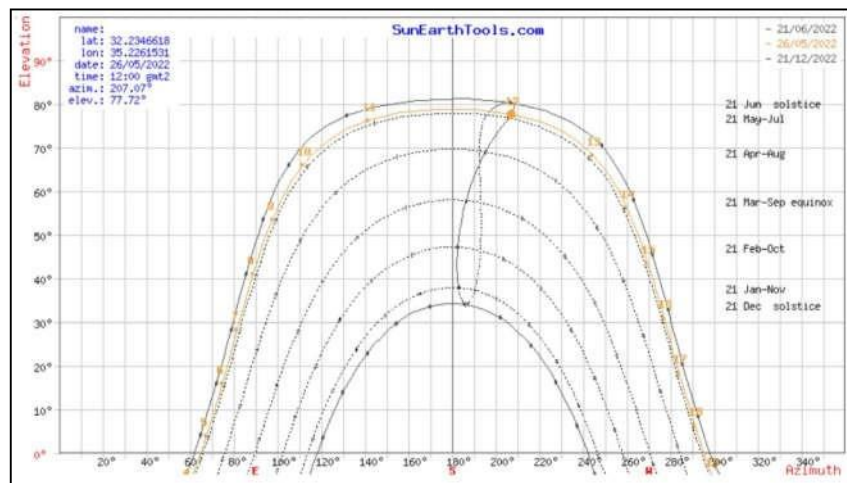

Figure 4-19: Relation between the azimuth angle and the elevation in winter

Wind:

The figure (4-20) for Bayt "Iba" which is near the site displays the number of days per month that the wind reaches a particular speed. The Tibetan Plateau provides an intriguing illustration, as the monsoon produces consistent strong winds from December to April and calm winds from June to October. The wind rose for Bayt IBA displays the number of hours the wind blows in that direction annually. SW example: The wind is blowing from the SW to the NE (NE). As shown in figure (4-21).

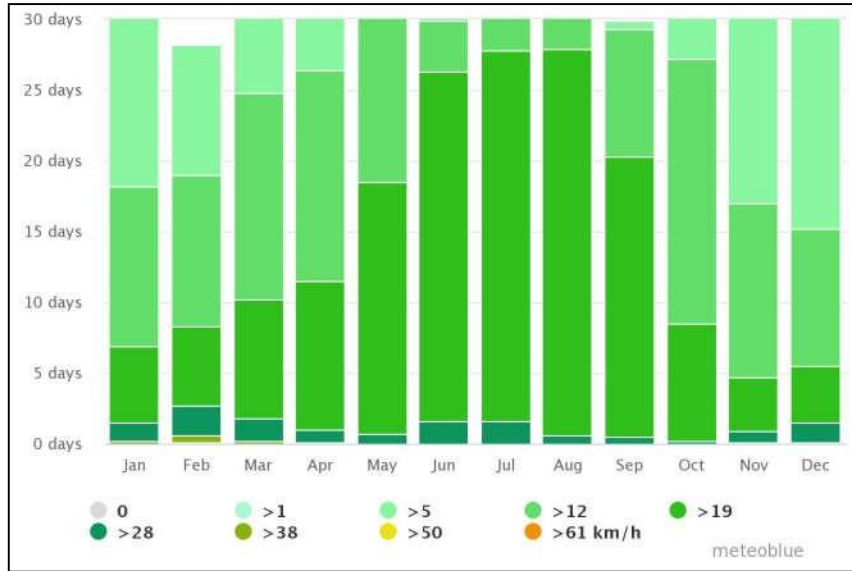

Figure 4-20: Wind speed in Nablus city

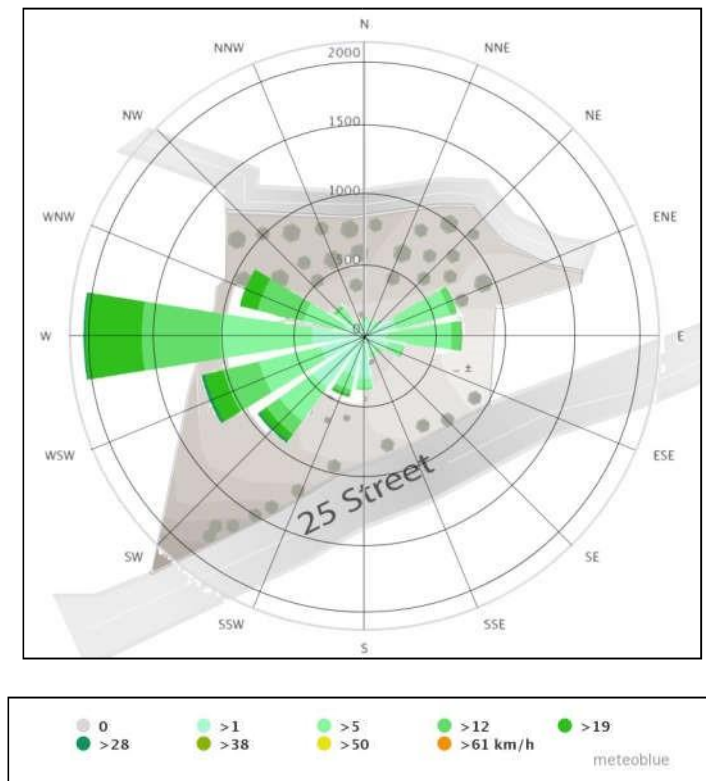

Figure 4-21: Wind rose diagram

Noise

The study of the nuisance is one of the things that must be considered in the project. Therefore, a site was chosen that is relatively quiet due to the lack of buildings in it, its distance from the

main streets, and the number of agricultural areas around it. The noise is mild from the north, as it is surrounded by residential buildings, while from the south, especially as it looks at 25 Street and the Al-Najah university area, also from the east, there is Haifa's main street, which the noise is higher from these directions. According to figure (4-22) we notice the land and the disturbance around it.

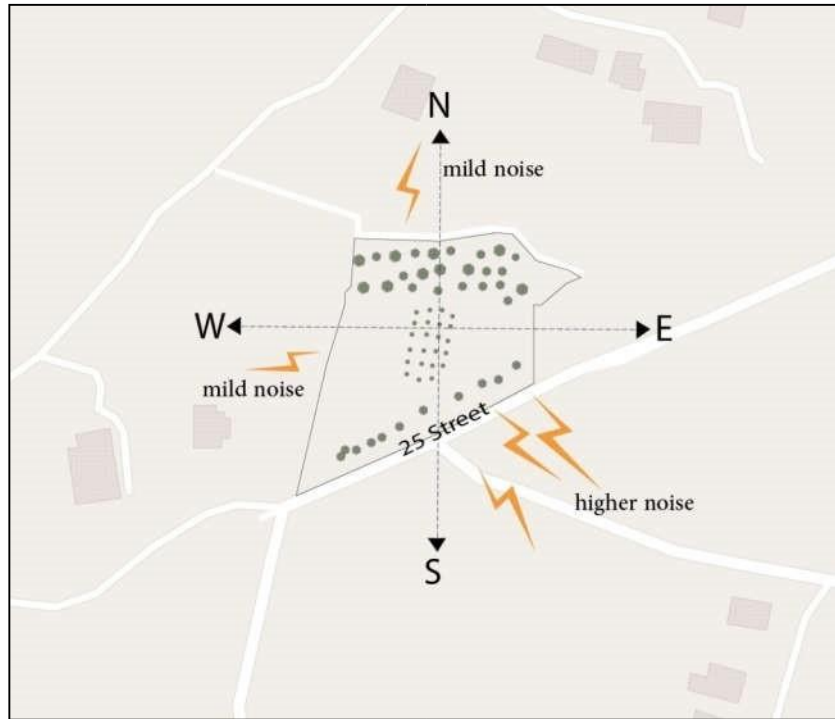

Figure 4-22: The disturbance around the site

Shading analysis

The figure (4-23, 4-24) shows the shaded areas of the In the morning and noon times , as the site of the land is not adequately shaded from the buildings around it, as the small number of buildings and their distance from the land makes the land more exposed to sunlight, as it is one of the positive points for the arrival of a large amount of sunlight to the reading areas, but Strategies must be put in place to reduce the amount of direct sunlight to the building.

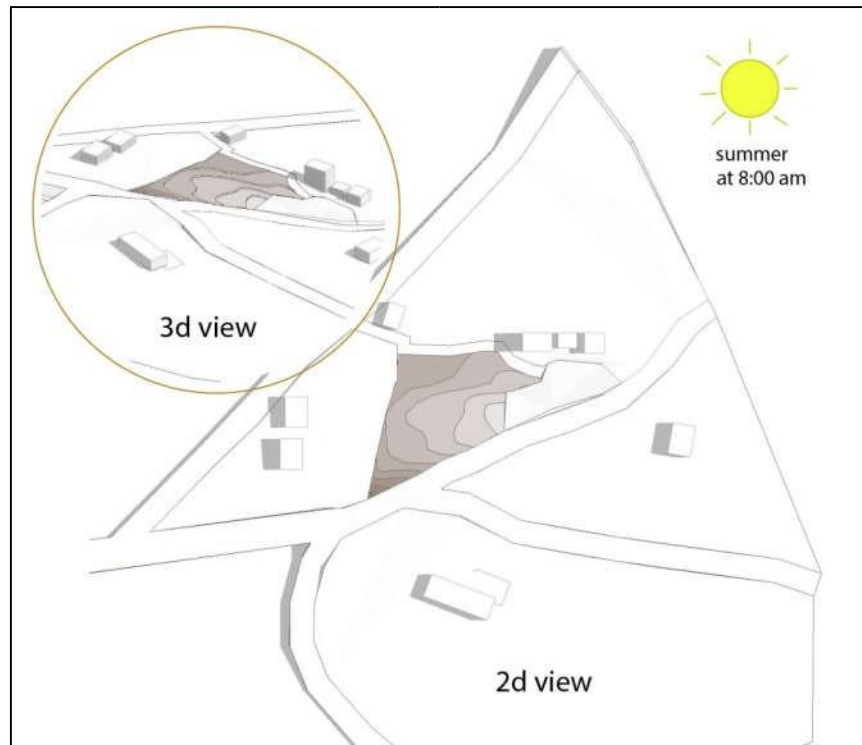

Figure 4-23: Shading analysis in the morning at 8:00 AM

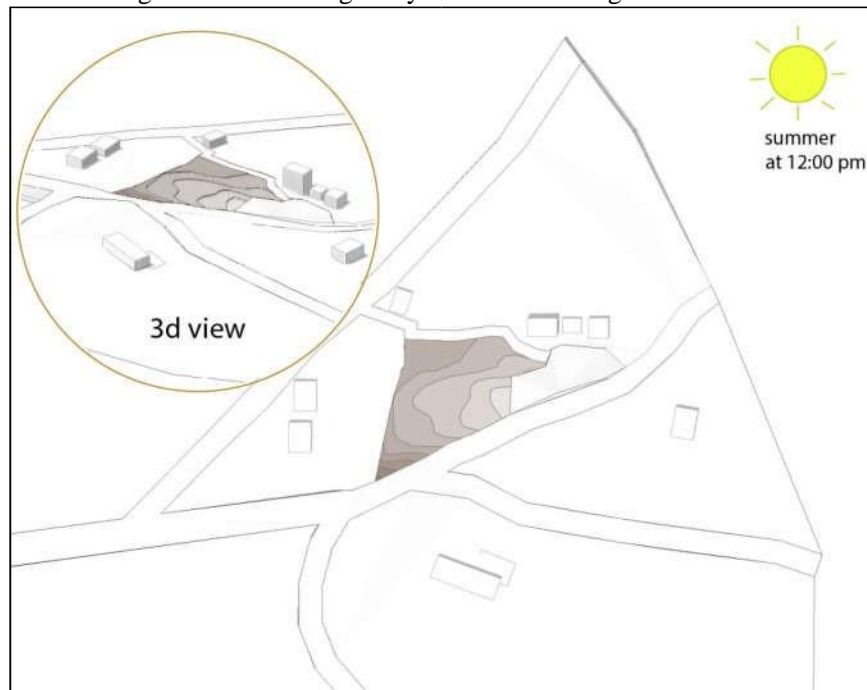

Figure 4-24: Shading analysis in the noon at 12:00 PM

Views

We can see the site from several perspectives, and this is what makes the project easy to access and view and figure no (25) shows the view rose of the site.

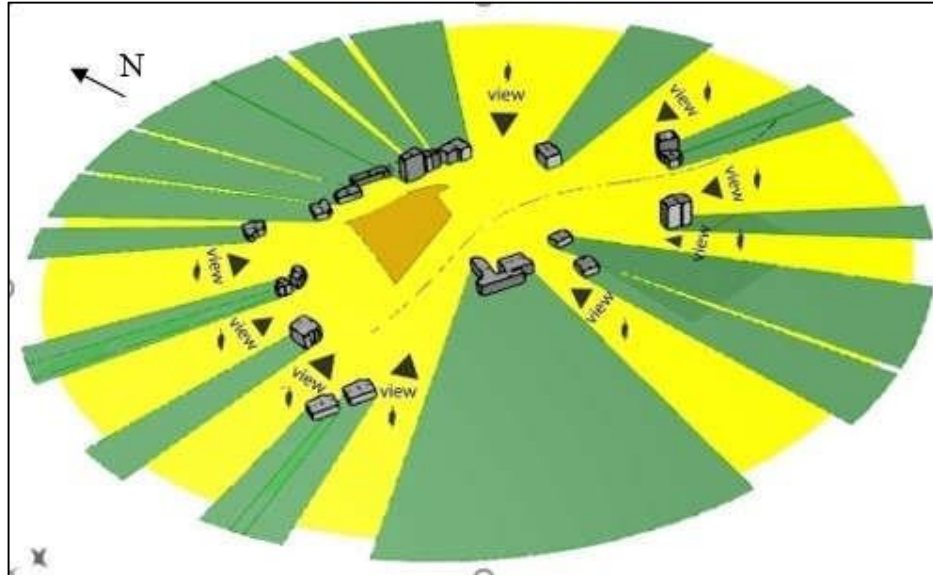

Figure 4-25: View rose of the site

Vegetation

On the site, there are some olive trees on the outskirts of the land, which must be preserved. In the middle of the land, there are some shrubs that are not of great importance and can be removed.

Chapter 5 Concept

5.1 concept design:

The smart library is the 21st century Library based on digital information technology, networks and artificial intelligence. It provides easy and convenient services for users and provides them with an interactive environment among them.

Shape development:

In order to make the library a garden, the shape of the building must be commensurate with the land and to give it smooth movement, and these curved lines suggest simplification and facilitation, and this is what the smart library called for. In order to make the library more interactive inside and outside the building, the levels were manipulated to give a path on the back of the building, in addition to providing a cafeteria service and an amphitheater at the top of the building as shown in figure no (5-1).

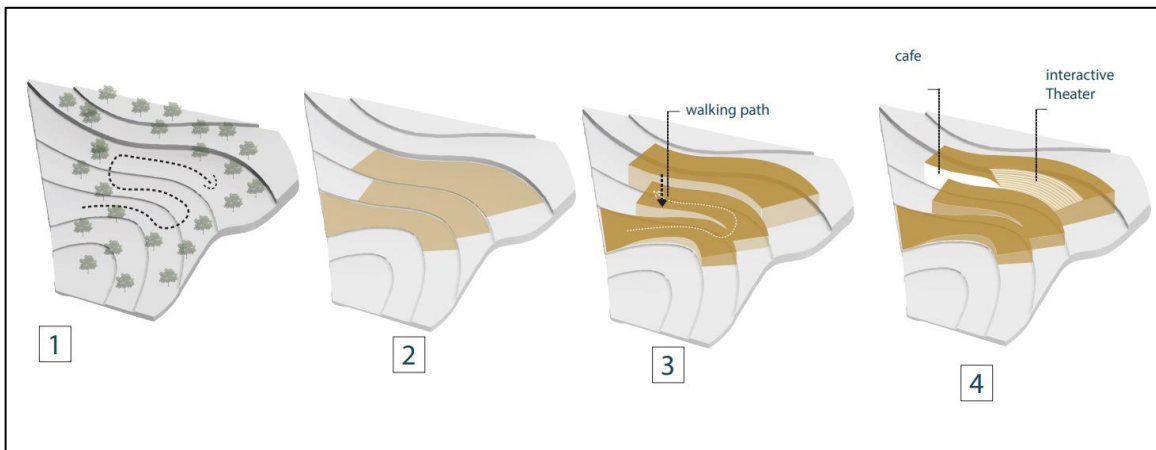
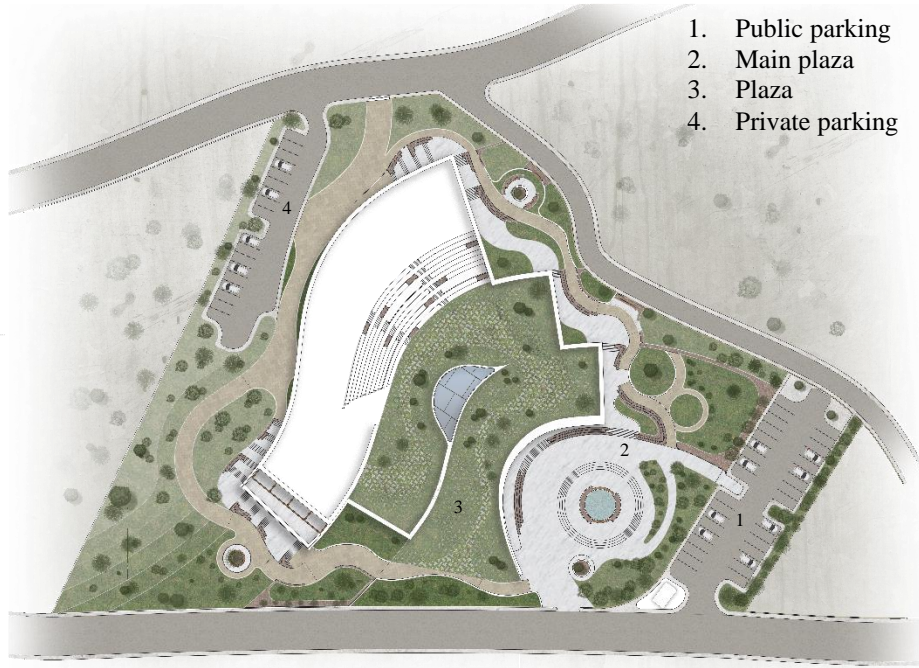

Figure (5-1): Building design concept.

5.2 Plans:

5.2.1. Site plan:

We took the entire land area of about 12800 square meters



5.2.2. Plan

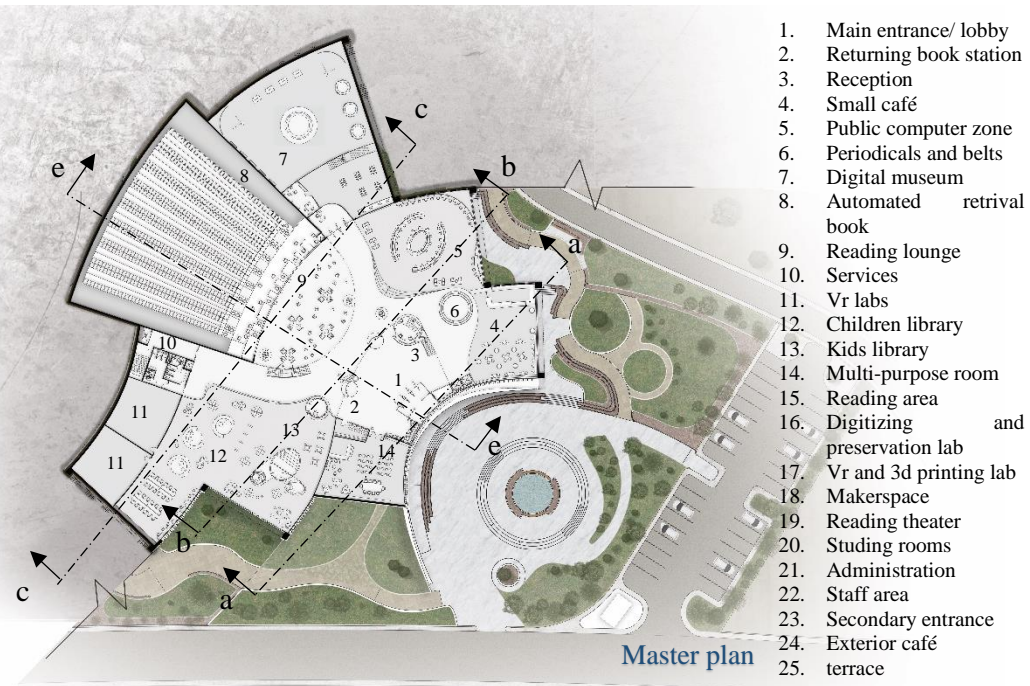

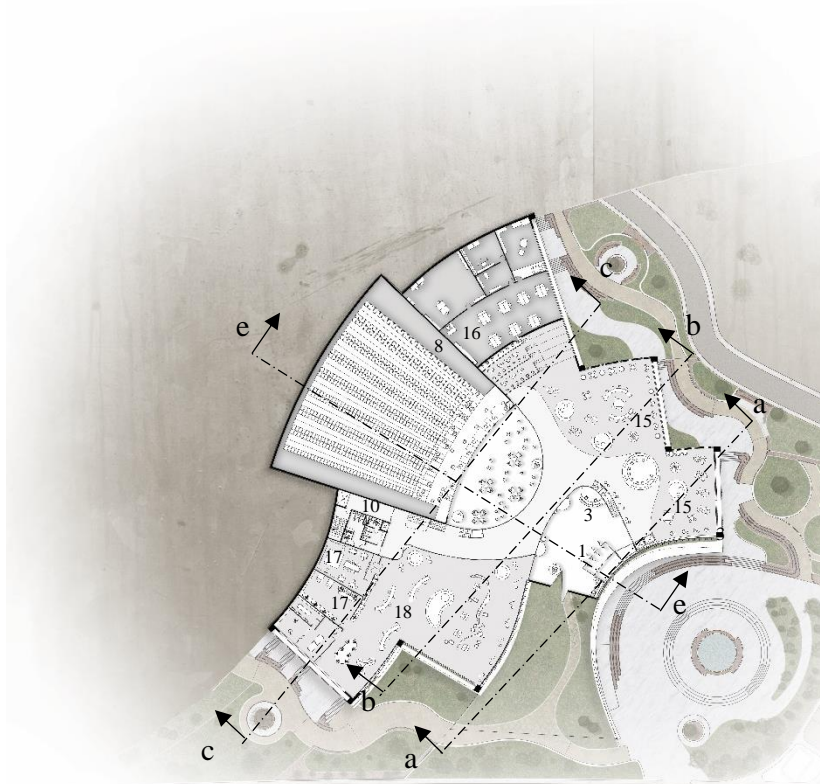

1. Main entrance/ lobby
2. Returning book station
3. Reception
4. Small café
5. Public computer zone
6. Periodicals and belts
7. Digital museum
8. Automated retrieval book
9. Reading lounge
10. Services
11. Vr labs
12. Children library
13. Kids library
14. Multi-purpose room
15. Reading area
16. Digitizing and preservation lab
17. Vr and 3d printing lab
18. Makerspace
19. Reading theater
20. Studing rooms
21. Administration
22. Staff area
23. Secondary entrance
24. Exterior café terrace
25. terrace

First floor

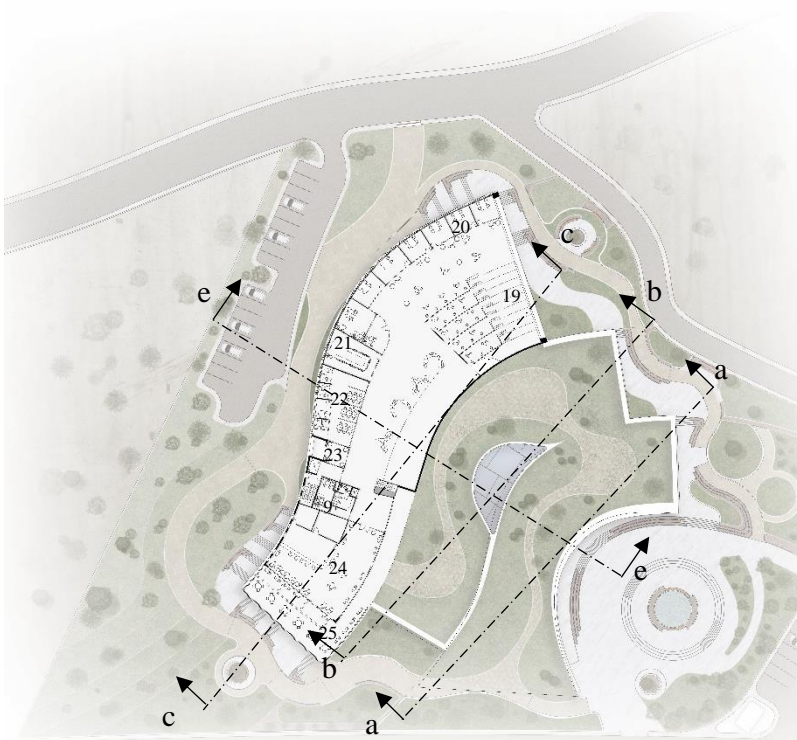

1. Main entrance/ lobby
2. Returning book station
3. Reception
4. Small café
5. Public computer zone
6. Periodicals and belts
7. Digital museum
8. Automated retrieval book
9. Reading lounge
10. Services
11. Vr labs
12. Children library
13. Kids library
14. Multi-purpose room
15. Reading area
16. Digitizing and preservation lab
17. Vr and 3d printing lab
18. Makerspace
19. Reading theater
20. Studing rooms
21. Administration
22. Staff area
23. Secondary entrance
24. Exterior café terrace
25. terrace

Second floor

5.2.3. Sections and elevations:

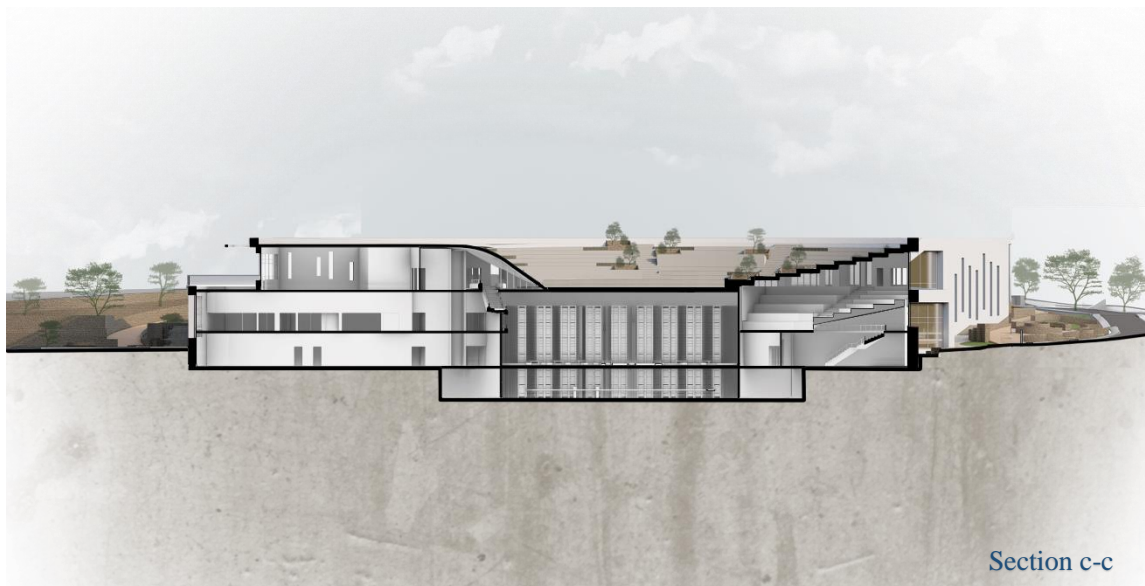
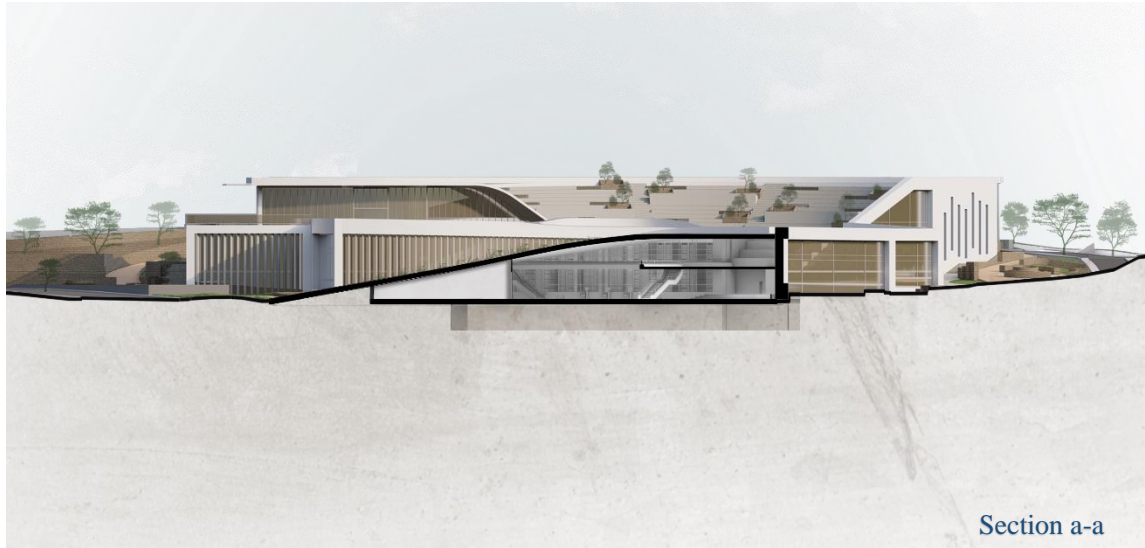

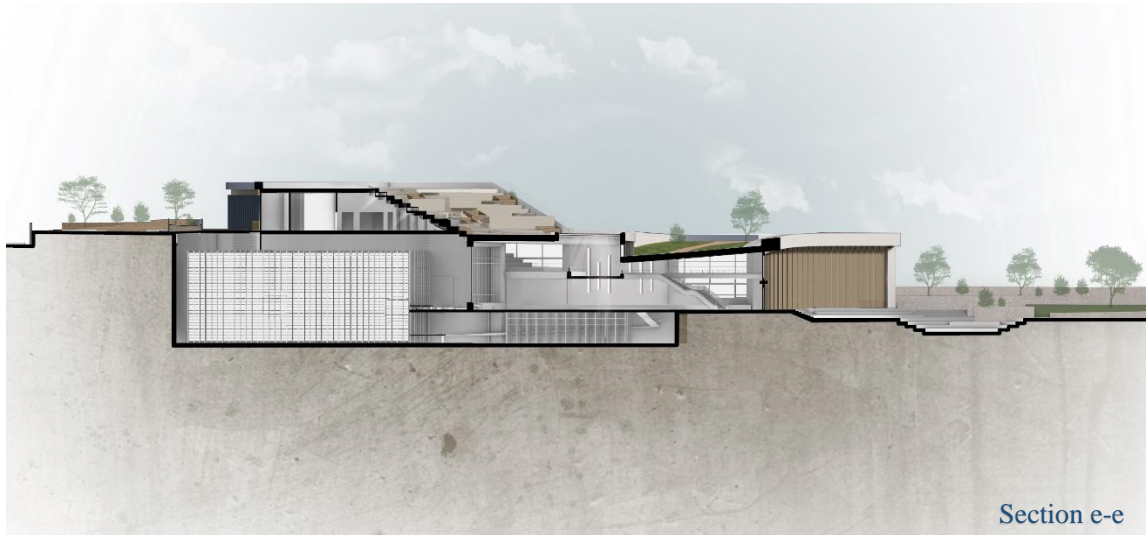



5.2.4. Perspectives

5.2.4.1. Exterior perspectives





5.2.4.2. Interior perspectives





References:

- [1] Muhammad Amin, Al- Banhawi , The World of Books, Reading and Libraries, Al-Arabi for Publishing and Distribution, Cairo, 1984.

- [2] Mrs. Meenu Malik.(2014). “Historical Development of Libraries”. ISSN 2321 –9726 (online) Volume .5, Issue 1. Page(s) : 61 – 71.

- [3] Dr. Hani Muhammad The library and Society; Libraries types and their impact on the rise of civilization, Dar al-elem w al-eman, 2009.

- [4] Brundaban Nahak, Satyajit Padhi. (2019). “The Role of Smart Library and Smart Librarian for E- Library Services”. IR @ INFLIBNET: The Role of Smart Library and Smart Librarian for E- Library Services.

- [5] Muhammad Majid, Al-Khalousi, Public and Private Libraries Buildings, Dar Qabes, 200.

- [6] Amer Ibrahim, Qandili, National Public Library, 1986.

- [7] Shah, A., & Bano, R. (2020). Smart library: Need of 21 st Century. Library Progress (International), 40(1), 1.

- [8] Kingsley N Igwe and Abdulakeem S Sulyman. (2022). “Smart libraries: Changing the paradigms of library services” Volume 39, Issue 4.

- [9] Schöpfel, J. (2018). Smart Libraries. *Infrastructures*, 3(4), 43.
- [10] palmuseum.org.Available .The Palestinian Museum N.G (palmuseum.org).
- [11] مكتبة نابلس العامة.. رائدة العلم والثقافة وأيقونة التاريخ | ثقافة | الجزيرة نت (aljazeera.net).
Aljazeera.net.
- [12] Public libraries and their role in the development of the Arabic book, inspired by the experience of the Islamic University.
- [13] Katia Medawar. (2021). “Setting up a New Library: Planning, Challenges, and Lessons Learned”. A Case Study about Qatar National Library, *International Information & Library Review*, DOI: 10.1080/10572317.2021.1898757.
- [14] The Architectural Review. 6 March 2019,
<https://www.architectural-review.com/buildings/tales-of-the-unexpected-qatar-national-library-doha-by-oma>
- [15] Taylor and referances online, 22 Mar 2021, Full article: Setting up a New Library: Planning, Challenges, and Lessons Learned. A Case Study about Qatar National Library (tandfonline.com).
- [16] INSIDE OUTSIDE, (2016) , Qatar National LibraryDoha - Inside Outside.

- [17] Corina Pop, Automated material handling systems (AMHS) in libraries and archives: automated storage/retrieval and return/sorting systems, April 2011. (PDF) Automated material handling systems (AMHS) in libraries and archives: automated storage/retrieval and return/sorting systems (researchgate.net).
- [18] epl.ca, Makerspaces at EPL | Edmonton Public Library.
- [19] Tawfiq Saleh and Abdelhaleem Khader , Urban Particulate Matter Hazard Mapping and Monitoring Site Selection in Nablus, Palestine.
- [20] Simulated historical climate & weather data for Bayt Ībā - meteoblue.
- [21] Simulated historical climate & weather data for Bayt Ībā - meteoblue.
- [22] Calculation of sun's position in the sky for each location on the earth at any time of day (sunearthtools.com).

