



# **An-Najah National University**

Faculty of Engineering and Information Technology

Department of Computer Engineering

Graduation Project II

## **Be My Eye**

Done by:

Rahaf Nawaas & Ruwaa Shehadeh

Supervised by:

Dr. Ra'ed Al-Qadi

Date: May,2022

---

Presented in partial fulfilment of the requirements for  
**Bachelor Degree in Computer Engineering**

## **Acknowledgment**

For your guidance and protection,over and again thank you Allah,it would not have been possible without your blessings throughout our graduation project work to complete it successfully.

We are so grateful to our supervisor Dr. Ra´ed Al-Qadi , were so lucky to have him as our supervisor, thanks for always listening to us and supporting us .

To our families who have always honored us with their love and support, thank you for always being by our side, and to our family in the computer Engineering Department ,thanks to them for their efforts ,we are super proud to be part of this family.

# Contents

|          |  |           |
|----------|--|-----------|
| <b>1</b> | <b>Abstract</b>                                  | <b>4</b>  |
| <b>2</b> | <b>Introduction</b>                              | <b>5</b>  |
| <b>3</b> | <b>Constraints, Standards and Course Work</b>    | <b>6</b>  |
| 3.1      | Constraints . . . . .                            | 6         |
| 3.2      | Earlier coursework . . . . .                     | 6         |
| <b>4</b> | <b>Literature Review</b>                         | <b>7</b>  |
| <b>5</b> | <b>Methodology</b>                               | <b>8</b>  |
| 5.1      | Product design . . . . .                         | 9         |
| 5.1.1    | Stick . . . . .                                  | 9         |
| 5.1.2    | Small box . . . . .                              | 10        |
| 5.1.3    | Hardware part (Electronic components ) . . . . . | 11        |
| 5.1.4    | Libraries . . . . .                              | 12        |
| 5.1.5    | The Process . . . . .                            | 13        |
| 5.1.6    | Circuits . . . . .                               | 19        |
| <b>6</b> | <b>Results and Discussion</b>                    | <b>20</b> |
| <b>7</b> | <b>Conclusions</b>                               | <b>21</b> |
| <b>8</b> | <b>Future Work</b>                               | <b>22</b> |
| <b>9</b> | <b>References</b>                                | <b>23</b> |

## List of Figure

|    |   |    |
|----|---|----|
| 1  | Be My Eye system . . . . .                  | 8  |
| 2  | Stick design . . . . .                      | 9  |
| 3  | Stick design . . . . .                      | 10 |
| 4  | Arduino Mega with speaker and GPS . . . . . | 10 |
| 5  | Object case . . . . .                       | 13 |
| 6  | upstairs case . . . . .                     | 14 |
| 7  | Downstairs case . . . . .                   | 15 |
| 8  | Hole case . . . . .                         | 16 |
| 9  | Tracking System . . . . .                   | 18 |
| 10 | Arduino Nano . . . . .                      | 19 |
| 11 | Arduino Mega . . . . .                      | 19 |

# 1 Abstract

There are many people around the world who have a disability like blind people, these people always have difficulty moving from one place to another because they are hardly able to detect the state or object in their way so they are more likely to get injured.

Be my eye is a system which improves and makes their life easier, it consists of smart stick and a small box, smart stick can detect any object and tell the user that there is an object on his way using the speaker, also it alerts the user when there is water or when the user is going to go upstairs or downstairs, in addition, it warns the user if there is a hole in front of him. Once this smart stick faced one of these cases, the stick will start to vibrate and buzzer sound will start also, the box will describe the case which faced the user through a speaker, this description can be in Arabic or English according to what the user chooses, moreover user's family can track the user by GPS.

This system is designed based on Audio which is interfaced with the required sensors, motors, and electronic components such as ultrasonic sensors, vibration motor, buzzer, GPS module, etc.

## 2 Introduction

People who are completely blind or have impaired vision usually have a difficult time navigating outside the spaces that they're accustomed to. In fact, physical movement is one of the biggest challenges for blind people because it can become tricky to distinguish objects appearing in front of them, and they are not able to move from one place to another without their families.

Over the last decades, many experts and researchers tried to find solutions and ideas to solve problems related to vision including smart systems which have many types, characteristics, and features that are being developed today to reach an intelligent system capable of solving as many vision-related problems as possible.

Be My Eye is a smart stick specially designed to detect obstacles that may help the blind to navigate care-free. Voice messages alert the user and keep them connected to their surroundings to considerably reduce accidents. It includes sensors that interact with the environment outdoors or indoors, send the data to the Arduino for processing, and then the sound is released with the appropriate case so the blind person can move independently without the other person's help, also it contains a GPS so that the user's friends or family can know his location through an application to ensure his safety.

The main aim of our project is to provide an efficient navigation aid for blind persons which gives a sense of vision by providing information about their surroundings and objects around them.

## 3 Constraints, Standards and Course Work

### 3.1 Constraints

- It was so difficult to find some hardware components, and this affected the development of the ideas ,also the low quality of the available parts even before they were used, so we had to replace them more than once ,in addition to the high prices of the electrical parts in Palestine compared to other countries.
- The sensors which used are very sensitive, and the accuracy of some of them becomes not high.
- GPS module sometimes disconnect and sometimes take time to connect again.
- The Blynk IOT app used with GPS is no longer free and we have paid to use it and renew its subscription every month.

### 3.2 Earlier coursework

We took Arduino courses in which we learned how to deal with it and do some basic wireless projects that facilitate the process of implementing and developing our project also the courses that we learned with The Computer Engineering Department provided us with basic knowledge and skills that helped us to build this system, such as Microprocessor, Microcontroller, Digital Design, Electronic Circuits and Electrical Circuits.

## 4 Literature Review

Nowadays, Technology is widely used in healthcare which has many benefits that will reduce the suffering of patients and find alternative solutions so that the patient can participate efficiently in his daily life and carry out his work. Many scientists and engineers have worked to develop smart systems to help people with visual problems, especially blindness, some of them focused on the movement of the blind person, because the development of a system to help him has become, over the years, an absolute necessity.

The wearable health monitoring systems which are designed for visually impaired people ,they are mainly developed to help the blind person to move alone safely from one place to another and to avoid any obstacles and here we mention some of the ideas and projects that have been implemented previously :

Sensor assisted stick for the blind people in which the infrared sensor which is used to scan a predetermined area around the blind person by emitting-reflecting waves.[1]

Ali J. Ramadhan innovated a wearable smart system to improve the independent and safe physical movement of visually impaired persons. It includes an Arduino Uno with ATmega328 microcontroller . An Ultrasonic sensor is used to detect objects, an ADXL345 accelerometer is used for fall detection, and a voice sensor is used that detects the user's voice .[2]

An innovative stick is designed for the visually disabled people ,the stick is able to detect the water and the ultrasonic sensors are used to detect obstacles by using ultrasonic waves. By sensing the objects the sensor passes the received data to the microcontroller,The microcontroller calculates if the object is in front of the person. [3]

Most of the existing systems and solutions focus on avoiding obstacles, but they did not address some problems, such as going up and down stairs, or dangerous situations, such as the presence of a hole or the edge of a high place, and this is what we have worked to address in addition to the feature of alerting the user in more than one language. The user selects it by pressing the button on the stick.

## 5 Methodology

Basically, our project consists of an easy-to-use smart stick that detects certain situations that the user needs to be alerted to in order to pass or avoid them ,which are :

- Hit an object.
- Edge or hole
- Wet ground.
- Go upstairs.
- Go downstairs.
- Tracking system



Figure 1: Be My Eye system

## 5.1 Product design

### 5.1.1 Stick

We wanted to design a smart stick that is easy to use ,It has some features that make it user friendly :

- It is strong enough to support your weight made from Aluminum
- Its length can be easily controlled which makes it easy to keep in a bag or anything else .
- It is lightweight so that you can hold and move it in front of you without becoming tired
- It has a tip that grips the floor and does not slide.



Figure 2: Stick design

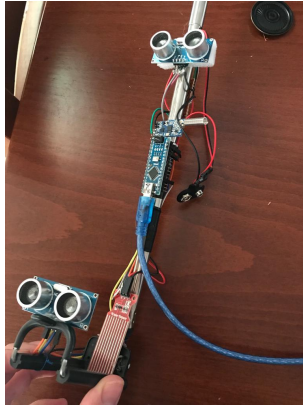

Figure 3: Stick design

### 5.1.2 Small box

A small light box that can be carried anywhere and installed on the bag or attached to the belt or tied around the hand and contains Arduino Mega that connected to a speaker so that the user can hear if she/he faced one of the cases through it.

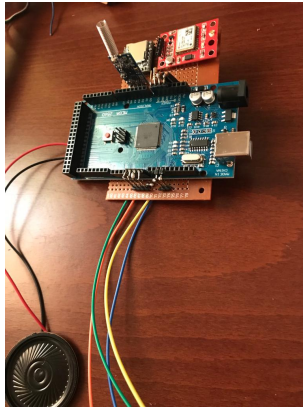

Figure 4: Arduino Mega with speaker and GPS

### 5.1.3 Hardware part (Electronic components )

Here the hardware components that we used :

- Arduino: Arduino is an open-source electronics platform based on easy-to-use hardware and software [4]. It has very powerful features and the software runs on multiple platforms.

We connected Arduino Nano with the distance and the water sensors to read the values and process them, and accordingly it sends a wireless signal to the Arduino Mega on the user's hand to decide which voice message is appropriate for the situation and speak to the user. .

- 2 HC-12 : Wireless serial module to send data from Arduino Nano to Mega
- ESP 8266 NodeMCU : we connect it with the GPS module
- GPS module : allow the family or the friends to locate the user to provide protection
- Water sensor : to detect if the ground is wet
- 3 distance sensors ( ultrasonic sensors (HC-SR04)) : used to detect the distance between the user with any object in front of him,also we used 2 sensor to detect if there is an upstairs case in front of the user,we put one on the button and the other at an approximate height suitable for detecting the presence of the upstairs,and we used the 3ed one on the top of the stick to detect the downstairs case.
- MP3 module: to tell the user about the situation he may be facing
- Force sensor : starts sensing when the stick touches the ground
- Vibration motor : generate vibrations to warn the user if one of the specific situations about to happen
- 8  $\Omega$  speaker : used with the MP3 module.
- 9 volts batteries .
- Resistance

#### 5.1.4 Libraries

- `<HCSR04_ultrasonic_sensor-2.0.3>`: *used for the ultrasonic sensors.* [4]
- `<RBD_WaterSensor-master>`: *used to allow the water sensor to detect the water*
- `<DFRobotDFPlayerMini.h>` : used for the MP3 Module with Arduino
- `<SoftwareSerial.h>` : used to allow serial communication between the Arduino and other electronic modules
- `<TinyGPS>`: used to provide the GPS functionality for feature tracking.
- `<ESP8266WiFi>` : used for setup the wifi in NodeMCU.
- `Blynk-library-master` : used to configure the connection between NodeMCU and Blynk app.

### 5.1.5 The Process

when visually impaired people hold the smart stick and the down edge of the stick touches the ground, the force sensor measures the force between the stick and the ground, once it exceeds 400, all sensors will start to detect the environments.

#### First case

while visually impaired people are walking using smart stick, if there is an object in 50cm front of him a vibration and buzzer sensors on the stick will be on and the Arduino nano on the stick will send 1 to Arduino mega which is in the smart box.

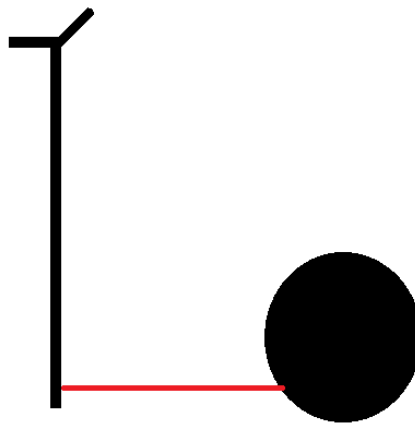

Figure 5: Object case

## Second case

When visually impaired people are about to go upstairs. To support this case, we used two ultrasonic sensors added at the lower half of the stick, the distance between these two sensors is 20cm.

The standard stairs' height is 15cm and standard width is 30cm. the distance between two ultrasonic sensors is 20cm to make sure the first ultrasonic sensor will measure the distance between the stick and the first rung of the stairs and the second sensor will measure the distance between the stick and the second rung. if the difference between these two measurements is near to 30cm value, the smart stick will start vibrations and send number 2 to the smart box.

surely, this scenario will be done once the down edge of the stick touches the ground the force sensor value exceeds 400 and there is a stair in 50cm front of the users.

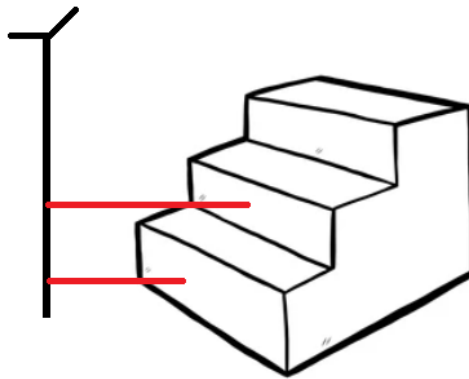

Figure 6: upstairs case

### Third case

The third case which may face visually impaired people is going downstairs. To support this case, there is an ultrasonic sensor added at the top of the stick as shown in figure-7, the height of the diameter when the stick is on flat ground is 100cm, got this value by experiment.

The Highest height for the diameter between two rungs of stairs will be almost 35 based on Pythagoras theorem, so the height of the diameter when there is a downstairs case is less than 135 and greater than 120. in this case, the smart stick will start vibrations and send number 3 to the smart box.

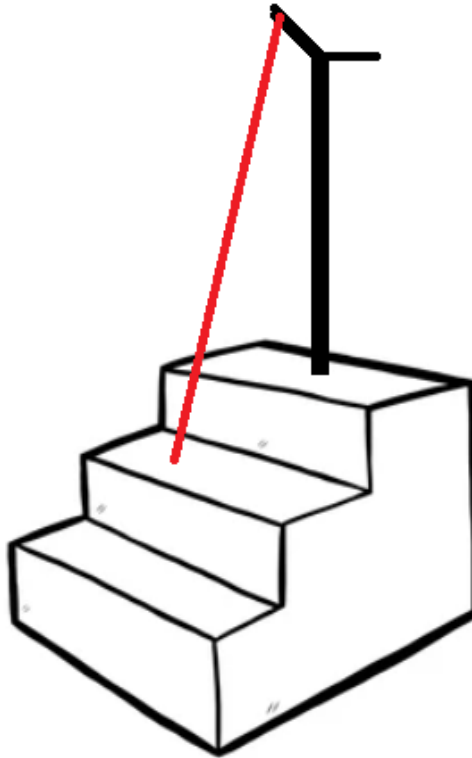

Figure 7: Downstairs case

### Forth case

forth case happen when there is a hole or and edge of a high place. To support this case, we use ultrasonic sensor which is at the top of the stick, when this sensor detects a vary high value so it's the hole case,the smart stick will start vibrations and send number 4 to the smart box.

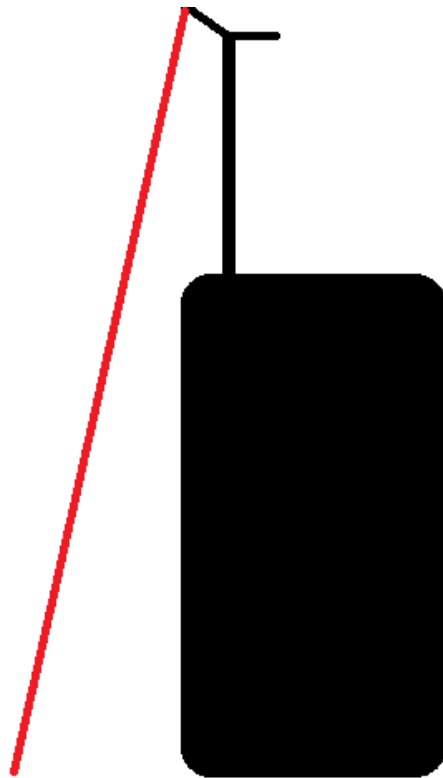

Figure 8: Hole case

### **Fifth case**

Last case is a water case, this case happens when the visually impaired people are about to walk on wet ground.

To support this case, a water sensor is used, once it detects water within a specific level, the smart stick will vibrate and send to smart box number 5.

If no one of these cases happens, smart stick will keep sending number 6 to the smart box. however, if more than one case happens at the same time, the case with the highest priority will be detected first. The priority is based on the case's danger.

The highest priority is when the visually impaired people are at the edge of a high place (Hole case), then when they are about to go downstairs, then when they are about to go upstairs, then if there is any object in front of them, finally if they are going to walking on wet ground.

All of these sensors will start to detect the environment in all cases once the down edge of the smart stick touches the ground, and the force sensor value exceeds 400 then, the smart box always receives a number between 1 to 6, if the number is 6 then means there is no dangers and the users can keep walking, but other numbers mean there is a danger, each number is related to a specific case and smart box will run a specific MP3 voice which is stored in a card added in mp3 module. Moreover, there is a switch button in a smart box that enables the user to choose the language when the switch is on the language of the MP3 voice will be in English, when the switch is off the language will be in Arabic.

## Tracking system

Tracking system feature also is added to [Be my eye] system which enables visually impaired people' family or friends to track their location by download Blynk app. To support this feature we use GPS module and esp8266 NodeMCU and blynk app.

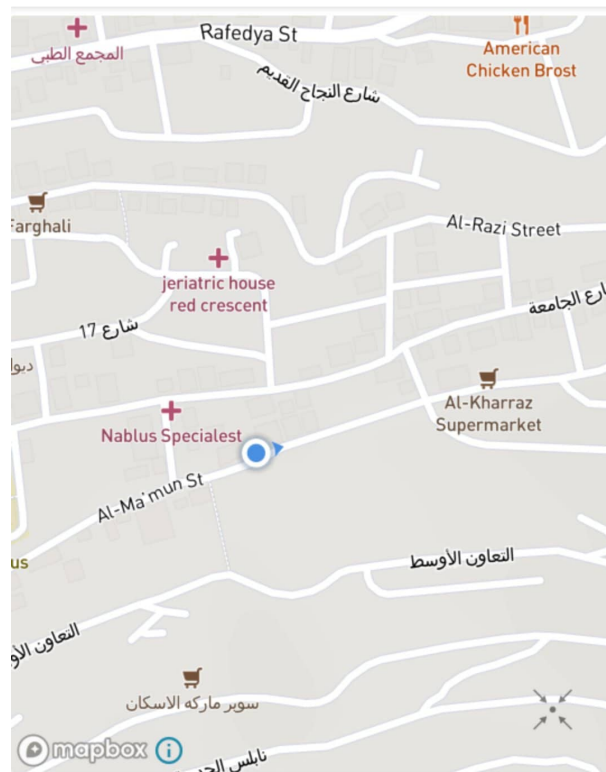

Figure 9: Tracking System

### 5.1.6 Circuits

Basically, we connected the sensors to the Arduino Nano, we connected the water sensor, the ultrasonic sensors, the force sensor and the vibration motor, also we connected the Wireless serial module (HC-12) to send data .

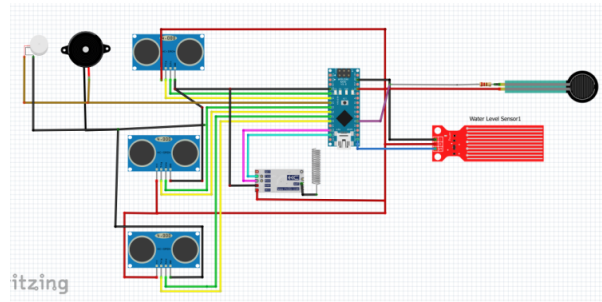

Figure 10: Arduino Nano

We connected ESP NodeMCU and GPS module with Arduino Mega ,also we connected MP3 module and the Speaker with it . Wireless serial module (HC-12) was connected to receive data from the stick

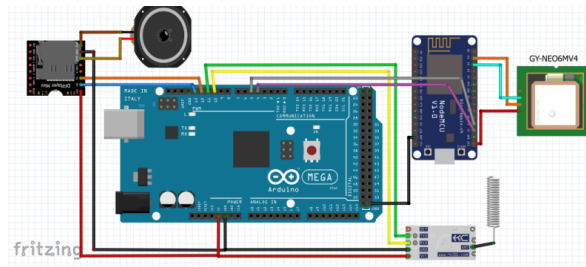

Figure 11: Arduino Mega

## 6 Results and Discussion

Despite some of the obstacles we faced, Be my eye system is an Arduino-based system that is about a smart stick with a box, this box works as a speaker to describe the situation to visually impaired people. this system improves visually impaired people's lives by allowing them to perform their work easily and reduce the danger they might face.

### **System outcomes:**

Smart stick can detect one of five cases, if the user is going to hit an object or if he is going to go upstairs or downstairs also, if he is in front of a high edge or if there is water on the ground.

Smart stick will start vibration and buzzer sound if the stick detects one of the five cases.

smart box will start to describe the case which faced the users with the chosen language.

The tracking system enables anyone from visually impaired people's family or friends to track him and know where is he at any time.

## 7 Conclusions

while building be my eye system, provides an unbelievable experience, knowledge, and skills for us like dealing with different types of hardware components like Arduino nano, Arduino mega, ESP8622 nodeMCU, NEO-6M GPS module, HC-12 wireless module, and many other sensors.

## 8 Future Work

Although all of these technologies and developments that control the world, there is nothing can work like our eyes

In the future, We can add many options for languages, and you can also add a clock that is controlled by a voice commands, something like Siri, to perform some tasks such as calling a person, setting an alarm, or searching for information through Google and then reading it to the user.

## 9 References

- [1]A. Dodds, D. Clark-Carter, and C. Howarth, The sonic PathFinder: an evaluation, *Journal of Visual Impairment and Blindness*, vol. 78, no. 5, pp. 206–207, 1984.
- [2]Ramadhan, A. J. (2018). Wearable smart system for visually impaired people. *Sensors*, 18(3), 843.
- [3]Balakrishnan, G., Sainarayanan, G., Nagarajan, R., Yaacob, S. (2007). Wearable Real-Time Stereo Vision for the Visually Impaired. *Eng. Lett.*, 14, 6-14.
- [4]Libraries - Arduino Reference.<https://www.arduino.cc/reference/en/libraries/>.Last access 10/5/2022.