



## An-Najah National University

Faculty of Engineering & Information Technology

Department of Electrical and Computer Engineering

### **Graduation Project 1**

---

#### **Automatic Power Factor Controller using Artificial Intelligence Technique**

---

#### **Supervised by:**

Dr. Imad Brik

#### **Prepared by:**

Mohammed Mustafa Fayek Issa 11925447

Mo'men Sa'ad Essam Salhab 11925516

Amr Mohammed Kamel Awaisa 12029378

Ala'a Haitham Fawzi Bani Fadil 12028088

Academic year 2023/2024

إهداء

بِسْمِ اللَّهِ الرَّحْمَنِ الرَّحِيمِ

قال تعالى: {وَقُلْ أَعْمَلُوا فَسَيَرَى اللَّهُ عَمَلَكُمْ وَرَسُولُهُ وَالْمُؤْمِنُونَ}

إلهي لا يطيب الليل إلا بشكرك . . . ولا يطيب النهار إلا بطاعتك

ولا تطيب اللحظات إلا بذكرك . . . ولا تطيب الآخرة إلا بعفوك

ولا تطيب الجنة إلا برويتك

الله جل جلاله

إلا من بلغ الرسالة وأدى الأمانة . . . إلى نبي الرحمة ونور العالمين

سيدنا محمد صلى الله عليه وسلم

إلى الذين لم يتوانوا يوماً عن تقديم الدعم والمساندة

ووقفوا بجانبنا في كل خطوة، بقلوبهم النابضة بالحب ودعواتهم الصادقة

والدينا الأعزاء

إلى الذين غرسوا في نفوسنا حب العلم والمعرفة

وكانوا لنا النبراس الذي نهدي به في طريقنا نحو التميز

مدرسينا الأفاضل

إلى شركاء الدرب والعطاء، الذين كانوا لنا عوناً وسنداً

وتقاسمنا معهم لحظات الجهد والتحدي

زملائنا وأصدقائنا

إلى كل من ساهم في إنجاح هذا المشروع، بكلمة طيبة أو نصيحة ثمينة

شكراً لكم جميعاً على ما قدمتموه لنا من دعم ومساندة.

ونخص بالذكر شهدائنا الأبرار، الذين قدموا أرواحهم فداءً لهذا الوطن الغالي

ليبقى حراً عزيزاً

ولا ننسى وطننا الغالي فلسطين، أرض الآباء والأجداد

إلى القدس الشريف، رمز الكرامة والصمود

إلى غزة العزة، الصامدة في وجه التحديات، التي تبث فينا روح الثبات والعزيمة

نسأل الله تعالى أن يكون هذا المشروع خطوة صغيرة لرد الجميل لهذا الوطن

العزیز.

## **Abstract**

At the height of the renaissance of electrical engineering and electrical power systems, it is necessary to pay attention to the efficiency of electrical energy and give it the greatest possible attention, to flow power with high efficiency and reduce the losses in the network. This reduces of the energy generated in power plants and reduces resources such as coal and oil that used on it, to maintain a clean environment free of gas emissions into the atmosphere. One of the most influential factors on losses is the increase in current passing through the network due to a low power factor. Therefore, Automatic Power Factor Controller using Artificial Intelligence Technique used to make power factor correction and compensate from the negative effects of electrical loads such as motors that result in a low power factor of the network. In this project, the power factor be Measured, Monitored, and controlled. If the value of Power factor becomes with negative effect on the Network as leading or lagging power factor, controlled it to achieved value [0.92 – 0.95] lagging by the use of capacitors or reactors. And measuring and displaying : “Power Factor, Voltage, Current, Real Power, Reactive Power, Energy, and average power factor”. Artificial intelligence used for improvement, control, monitoring, and taking the necessary appropriate measures to avoid problems in the operation of the system, obtain the best possible results, and facilitate the user.

# Table of Contents

إهداء .....	II
Abstract .....	I
Table of Contents .....	II
List of Figure .....	IV
List of Tables .....	IV
List of Abbreviations .....	V
Disclaimer .....	VII
Constraints .....	VIII
<b>CH 1 Introduction .....</b>	<b>1</b>
<i>1.1 General background</i> .....	1
<i>1.2 Problem Statement</i> .....	2
<i>1.3 Motivation of AI</i> .....	2
<i>1.4 Purpose</i> .....	3
<i>1.5 Report Structure</i> .....	4
<i>1.6 Methods for improving power factor</i> .....	4
<b>1.6.1 Over-Excited Synchronous Motor</b> .....	4
<b>1.6.2 Phase Advancer</b> .....	5
<b>1.6.3 Capacitor Bank</b> .....	5
<b>CH 2 Literature Review .....</b>	<b>7</b>
<i>2.1 Introduction</i> .....	7
<i>2.2 A summary of previous research</i> .....	7
<b>CH 3 Methodology .....</b>	<b>13</b>
<b>3.1 Programs we used</b> .....	13
<b>3.1.1 Arduino IDE Program</b> .....	13
<b>3.1.2 Proteus Program</b> .....	14
<b>3.2 Power factor</b> .....	14
<b>3.3 Project Components</b> .....	16
<b>3.3.1 Indicative load:</b> .....	16
<b>3.3.2 Source:</b> .....	17
<b>3.3.3 Transformers:</b> .....	17
<b>3.3.4 Zener diodes:</b> .....	17
<b>3.3.5 Zero Detection Circuits (Op-Amps):</b> .....	17

3.3.6	XOR Gate: .....	17
3.3.7	Transistors: .....	18
3.3.8	Capacitor banks: .....	18
3.3.9	Relays:.....	18
3.3.10	ACS712ELCTR-30A-T:.....	18
3.3.11	LCD 20×4 Screen: .....	19
3.3.12	Arduino Uno: .....	20
3.4	<i>Project work mechanism:</i> .....	20
3.4.1	Load Units.....	21
3.4.2	Phase shift display circle .....	22
3.4.3	Capacitor Banks Units.....	24
3.4.4	Current and Voltage Measurement Circuit .....	25
3.4.5	Arduino Connection .....	25
3.5	<i>Project code:</i> .....	27
CH 4	<b>Results and Analysis .....</b>	<b>41</b>
4.1	<i>Phase shift value and power factor before the optimization process .....</i>	<i>42</i>
4.2	<i>Phase shift value and power factor after the optimization process.....</i>	<i>43</i>
4.3	<i>The value of real power, reactive power, real energy, and reactive energy before the optimization process</i>	<i>44</i>
4.4	<i>The value of real power, reactive power, real energy, and reactive energy after the optimization process</i>	<i>46</i>
4.5	<i>Waveforms of voltage and current and the time difference between them.....</i>	<i>49</i>
CH 5	<b>Conclusions and Recommendation.....</b>	<b>53</b>
5.1	<i>Conclusion.....</i>	<i>53</i>
5.2	<i>Recommendation .....</i>	<i>54</i>
5.3	<i>Future Work .....</i>	<i>54</i>
References.....		56

## List of Figure

Figure 1: The Power Triangle.	1
Figure 2: power factor correction using Synchronous condenser.	4
Figure 3: Automatic capacitor bank for power factor correction	5
Figure 4: Capacitor Structure.	5
Figure 5: Capacitor bank for substation.	6
Figure 6: Arduino IDE program.	13
Figure 7: Proteus simulation program.	14
Figure 8: phase shift, and power triangle.	15
Figure 9: The current consumed lags behind the voltage.	16
Figure 10: Capacitor banks.	18
Figure 11: ACS712ELCTR-30A-T.	19
Figure 12: LCD 20×4.	19
Figure 13: Arduino Uno.	20
Figure 14: Project design.	20
Figure 15: Load units.	21
Figure 16: Phase shift display circle	23
Figure 17: Capacitor Units.	24
Figure 18: Current and voltage measurement circuit.	25
Figure 19: Arduino circuit.	26
Figure 20: Phase shift value and power factor before the optimization process at case 6	42
Figure 21: Phase shift value and power factor after the Correction process at case 6	43
Figure 22: Value the current, power factor, and voltage before setting the capacitor bank to case 6	45
Figure 23: Real energy and reactive energy before activating the capacitor bank for case 6	45
Figure 24: Value the current, power factor, and voltage after setting the capacitor bank to case 6	47
Figure 25: Real energy and reactive energy after activating the capacitor bank for case 6	47
Figure 26: PF.avg a period of time of 30 minutes	48
Figure 27: PF.avg a period of time of 100 minutes	49
Figure 28: Waveforms with all loads separated.	50
Figure 29: Waveforms with 100-ohm operation.	50
Figure 30: Figure 30: Waveforms with five loads running and capacitors disconnected.	51
Figure 31: Waveforms with five loads on and capacitors activated.	52

## List of Tables

Table 1: Literature Review Summary.	10
Table 2: XOR Gate.	17
Table 3: Phase shift value and power factor before the optimization process.	42
Table 4: Phase shift value and power factor after the Correction process.	43
Table 5: The value of real power, reactive power, real energy, and reactive energy before the Correction process.	44
Table 6: The value of real power, reactive power, real energy, and reactive energy after the optimization process.	46

## List of Abbreviations

A	Ampere
AI	Artificial Intelligence
C	Capacitor
CSA	Cross-Sectional Area of Cables
CT	Current Transformer
EP	Energy for Active Power
EQ	Energy for Reactive Power
I	Current
L	Inductor
Lag	Lagging
P	Active Power
PF	Power Factor
PFavg	Power Factor Average
PFC	Power Factor Controller
PT	Potential Transformer
Q	Reactive Power
R	Resistance
S	Apparent Power
V	Voltage
v	Volt
VA	Volt Ampere
VAR	Volt Ampere Reactive
W	Watt
Xc	Capacitor Reactance
XL	Inductance Reactance
XOR	Exclusive OR
Z	Impedance
$\eta$	Efficiency
$\theta$	Phase Shift Between Voltage and Current
$\theta_i$	Current Angle
$\theta_v$	Voltage Angle

## **Acknowledgment**

“Praise be to God, by whose grace good deeds are completed, through whose favor blessings and bounties descend, and with whose guidance goals and aspirations are achieved. Blessings and peace be upon the mercy of God sent to the worlds, His favor granted to the believers, and his clear proof to all people our master, our leader, our example, our beloved, and our teacher, Muhammad. And upon his family, his companions, those who follow his path, and those who are guided by his tradition until the Day of Judgment. We want to express our heartfelt gratitude to our project supervisor, Dr. Imad Brik, for his unwavering commitment and unceasing support. Our success has been greatly attributed to his invaluable scientific guidance. we would like to thank the Electrical Engineering Department faculty for their knowledge and support. We also want to express our gratitude to our family and friends for their unwavering faith in our abilities. We are incredibly grateful for their contributions, encouragement, and faith in our abilities. Lastly, we extend our thanks to our nation, where we have grown and thrived”.

## **Disclaimer**

The report has been authored by students connected to the Department of Electrical Engineering at An-Najah National University's Faculty of Engineering. It has undergone minor revisions, with the main focus being on editing enhancements, but there may still be linguistic and substantive errors. It is imperative to underscore that all perspectives articulated in the report, encompassing conclusions and recommendations, are exclusively those of the students. If this report is used for purposes other than those for which it was intended, An-Najah National University will not be held accountable or responsible for any consequences.

## Constraints

During the course of this project, we encountered several challenges and difficulties, among the most notable were:

### 1 Time Constraints:

- Nature of the Academic Term:

The division of the semester into two periods placed significant pressure on us, as we had to balance coursework and related projects with the requirements of the graduation project.

- Project Idea Change:

Approximately two months into the semester, we were forced to change our project idea due to numerous obstacles that prevented us from continuing.

### 2 Limited Software and programs:

- Load Matching in Simulink on Proteus:

We couldn't find matching loads for specific motor values, to make the project realistic in Simulink.

- Limited programming ability:

This project depends on programming, and because of our lack of experience in programming, we faced obstacles in programming the project, which forced us to take online programming courses to increase experience and improve the project.

# CH 1 Introduction

## 1.1 General background

The spread of industrial plants has increased the number of electrical induction machines that consume two types of power: active power (P) and reactive power (Q). Increasing the amount of (Q) leads to a decrease (PF), and this effect leads to an increase in the Current (C) through the network, which affects its efficiency ( $\eta$ ), a drop in voltage (V) at loads, and increase the Capacity of transformers and generators.

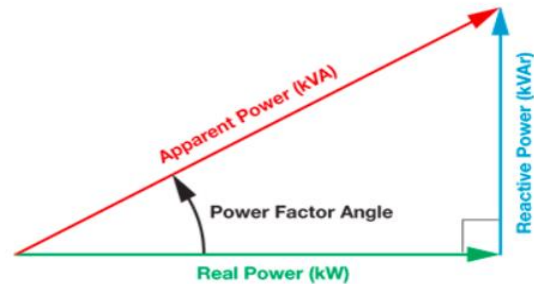

Figure 1: The Power Triangle.

This forces the electricity companies that supply the consumer with electrical energy to impose penalties on the consumer whose power factor is less than the value determined by the electricity companies, which is usually imposed if the power factors are less than (0.92) (Lag), and additional costs in the network also increase, such as increasing the cross-sectional area of cables (CSA) in transmission and feeding lines and increasing the size of protection and measuring devices. To avoid these additional costs, a Power Factor Controller (PFC) system implemented at loads using artificial intelligence (AI), by reducing the load's (Q) consumption issued by the network through an alternative source, such as adding capacitors in parallel with the load or using a synchronous motor over excited, or using the phase advance method, so reactive power consumption is reduced (Q), which leads to improving the power factor (PF) of the network and the current passing through the network decreases, which increases efficiency and increases the durability of the network elements.

The method of adding capacitors in parallel with the load highlighted and adopted in this project as a suitable method, because it low-cost solution and an easy way for the consumer to improve the power factor for several reasons, the most important of which is that the capacitors are characterized by low losses compared to other improvement methods and lack of maintenance due to the absence of mechanical parts for the capacitor, on the other hand, the capacitor has disadvantages, including the life span of the capacitor ranges between (8-10) years, and the possibility of damage to the capacitor if the voltage rises more than (1.1) of the nominal value of

the voltage, and most important of all is the improvement of the (PF) that can the (C) is carried out by capacitors in steps not continuously. This means that they do not work to accurately obtain any value we want for the power factor. This problem will later be dealt with in the best possible way using artificial intelligence and microcontrollers. The method of adding capacitors in parallel with the load is used either manually or automatically. In manual optimization, fixed capacitors are added, but with changing loads, this may lead to damage at low loads. Therefore, devices must be available to measure and improve the power factor automatically. Power factor (PF). It is calculated by dividing the apparent power (P) by the reactive power (Q) because it is the angle between them and is equivalent to the time delay between the voltage wave and the current. It is measured by a zero-crossing detector circuit that transforms the form of the signal coming from the current transformer (CT) and the potential transformer (PT) on the load terminals from the sine wave to the square wave to measure and track the time of each signal and then compare it using the logic (XOR) gate and improve the power factor (P.F) automatically and appropriately using codes and artificial intelligence and show the best readings to the user.

## **1.2 Problem Statement**

Increasing the industry's electrical loads has led to a lagging power factor, resulting in increasing the current in the network, Extra losses in feeder cables, an increase in the size and costs of cables, the high voltage drop at the buses and the transformer, and Losses in the transformer. making it difficult to control the network parameters due to the Negative effect of the power factor, in the case of rapidly changing and sporadic loads.

## **1.3 Motivation of AI**

Artificial intelligence works to provide an appropriate and satisfactory solution for developing the power factor in electrical power systems, as correcting the power factor is an essential part of saving energy, especially in industrial facilities and the loads close to them. With artificial intelligence reaching a stage where it is possible to develop the power factor in a more effective way than before, there are several reasons, including correction of the power factor, where artificial intelligence can work on analyzing data with the change in the power factor at load & work to give

an activation order to capacitor banks effectively, and it also works to predict the maintenance date for each capacitor bank by analyzing data previously stored in the system in addition to the ability of artificial intelligence to know the age of capacitor bank, which helps it give a warning that the capacitor has reached the time to change it, to avoid extinguishing it, to increase the reliability of the system. Artificial intelligence also provides the ability to improve the distribution of capacitor banks effectively in a faster time based on the load curve information that is stored in the system's memory and its prediction of the nature of the load and the appropriate capacitors to activate, thus further enhancing the system's performance. All of this makes artificial intelligence a more reliable solution in improving the power factor and reaching a stable value within an appropriate range that prevents the user from receiving a financial fine, increases the efficiency of the system, and gives the user the ability to add other inductive loads, especially in industrial facilities.

#### **1.4 Purpose**

- Design a circuit to measure the phase shift between voltage and current.
- Using artificial intelligence to implement a control to automatically improve the power factor in electrical systems using capacitor banks.
- Develop a simple and effective user interface to manage the system and monitor the power factor automatically.
- Reducing dependence on imported devices such as (PLC), (SCADA) finding alternatives to them, and producing them locally so that the cost of production becomes less than the import price.
- Improve energy efficiency and reduce energy loss by fine-tuning the power factor.
- Providing a power factor control system characterized by flexibility and the ability to adapt to changing requirements in electrical loads.
- Measure the V, I, PF, and calculate P, Q, and S.
- Use artificial intelligence to enable us to keep pace with developments in the world, giving us opportunities to develop and compete in this field.
- The system's ability to make decisions and disconnect the system in the event of errors resulting from high or low voltage or current.

## 1.5 Report Structure

This project essentially studies power factor optimization using artificial intelligence in an effective way. It begins with an introduction that outlines the path to be taken, gives problems that can be addressed, and sets goals. A comprehensive literature review provides an overview by examining current research and methodologies. The main body of the research presents a sufficient analysis of the methodology used and gives insights into power factor control methods. The report ends by providing recommendations that highlight artificial intelligence in power factor development in the future.

## 1.6 Methods for improving power factor

The following methods for PF improvement.

### 1.6.1 Over-Excited Synchronous Motor

The power factor can be improved by using an overexcited synchronous motor (Synchronous condenser, or Synchronous capacitor). The method of use is based on operating this motor without load. In this method, it is considered a synchronous capacitor, it draws the  $Q$  to loads, which reduces the reactive component ( $Q$ ) (from source) and improves the power factor (PF), the advantage of using a synchronous condenser is step-less control power factor by varying the excitation, and supply high  $Q$ , in addition, this method is particularly suitable for large industries and is not economically feasible to improve PF less than 0.5 MVAR.

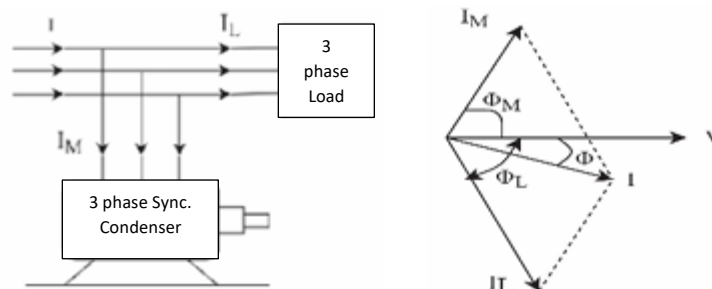

Figure 2: power factor correction using Synchronous condenser.

### 1.6.2 Phase Advancer

Also one of how the power factor is improved is Phase Advancer Which is used especially in induction motors, this type of motor suffers from low PF Because its stator coil draws a current lagging the supply voltage by an amount of 90 degrees, this method provides the phase advance circuit with additional ampere cycles from a separate alternating current source to compensate for the lagging current in the stator, it is installed on the rotor shaft of the motor and provides additional ampere cycles during operating cycles or low load, which enhances PF.

### 1.6.3 Capacitor Bank

Finally, capacitors were used in the process of improving the power factor, as they are considered the best method and work to store electrical energy between two metal plates separated by an insulating material, in which the energy storage process takes place, in addition, these capacitors are installed in parallel with the inductive loads, so they work to charge and discharge in the opposite way to the coils in the loads. The effect of this process is that the lag of the current over the voltage is reduced, and thus it will improve PF.

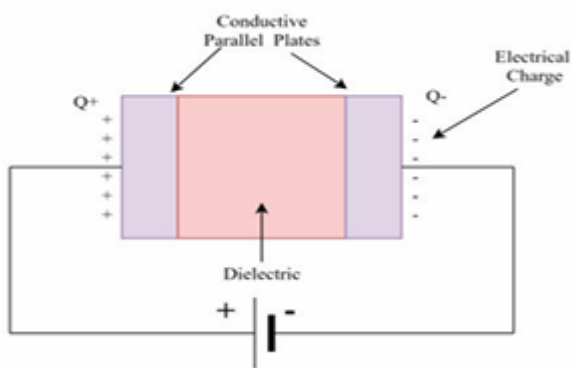

Figure 4: Capacitor Structure.



Figure 3: Automatic capacitor bank for power factor correction



*Figure 5: Capacitor bank for substation.*

## CH 2 Literature Review

### 2.1 Introduction

The process of controlling the power factor (PF) is considered one of the most important things that all industrial facilities need, as it contributes to many developments and contributes to reducing the costs of loads' energy consumption, in addition to the different methods used to improve the power factor, with the development of the world, this has become easier to achieve, with the revolution in artificial intelligence and the emergence of many microcontrollers of all kinds, it is very important to compare Finite Element Analysis (FEA) studies and theoretical analysis according to the American University's guidance on controlling the power factor automatically, because of the diversity of the techniques used, it enables engineers to verify the validity and safety of the simulation results through standards that provide a guarantee of both efficiency and compatibility in design standards, secondly, these studies allow us to apply this simulation without fear because it guarantees us satisfactory results and also the ability to develop it, to become the best you can be, in addition, simulation programs such as Proteus have played a major role in the process of monitoring control and improvement in power factor with the possibility of harmonizing and predicting how this process will proceed. This chapter comprises several studies covering all the artificial intelligence methods used in automatic power factor control. There is a table. A literature review summary is shown at the end of the chapter.

### 2.2 A summary of previous research

**(Mane, Sapat et al. 2020)** This study aims to improve the power factor to 0.9 or higher ideally, and this is done through methods such as capacitor banks using an Arduino Uno ATmega328 microcontroller as well as designing a simulation system on (MATLAB), where the system runs automatically, which Reduces reaction force and increases efficiency. The microcontroller monitors the power factor of the system and adds relays in parallel with the loads to maintain the desired range. This system operates at 415V, 50Hz, and displays the results on an LCD screen. Satisfactory results were achieved, and the power factor reached 0.9 and above automatically. While **(Tai, 2018)** this article explains how to read the current voltage and the three-phase voltage, using the current transformer and the voltage transformer by reducing their values to a value that the control device can tolerate, and Then, it processes the data entered into the processing unit and

issues commands to the capacitor banks to activate them in parallel with the load, where the capacitor reduces the QL to an acceptable value to the extent that the power factor reaches a value close to 1. The Arduino board was used in this project for its cheap price, appropriate and effective performance, and the possibility of use. In more than one place, such as factories, companies, and even homes, which leads to reducing traffic losses through the network and reducing fines for factory owners. Network simulation. The system was implemented on the Proteus program, and a circuit was designed that simulates the circuit that can be designed and installed by the user and the results are displayed on the LCD screen. The research aims to explain the effective and apparent power and reactive power the difference between them and the effect of raising the power factor on each of them. The values of the capacitor banks necessary to correct the power factor were also calculated and they were automatically activated using the processing unit. The result was an automatic power factor correction circuit that is very useful for improving the power factor and reducing Currents passing through the cables, thus reducing losses and fines and increasing the efficiency of the network, which in turn leads to reducing the amount of energy needed to be generated in generating stations. Also (**Ishak et al., 2015**) this article present an automatic technique for power factor correction using a microcontroller, using a current and voltage converter. , and zero-crossing detectors. The method is based on converting current and voltage signals into a square wave, then comparing the two waves to each other, calculating the time difference between the two waves, and sending the output to the microcontroller, which works through written code that converts time into an angle difference and uses the angle difference to activate and deactivate the connected capacitor banks. In parallel with the load to reduce the value of (QL), if the power factor is less than 0.9, the microcontroller activates the capacitor banks (and activates the most appropriate one to raise the power factor), and if it is very close to 1, it works to disconnect the capacitor banks to ultimately obtain a close power factor. Very much from 1 and not exceeding it. The research presents some of the results obtained through the practical experience of the project. While (**Bayindir et al., 2009**) this study relies on the use of the artificial neural network (ANN) controllers and reliance on synchronous motors to compensate for the reactive power and improve (PF) and the ANN using objective learning algorithms such as Backpropagation with Momentum (BP), Delta-bar-delta (DBD), Extensive delta-bar-delta (EDBD) and Directed Random Search (DRS) on the system intelligently conveys the precise information, hence The information issued by the ANNs is fed into the PIC 16F877

microcontroller, which works to control the power factor improvement process. In conclusion, it was shown that when the ANN is integrated with the microcontroller, this leads to a fast improvement process, high accuracy, durability and effectiveness of the system. It has also been enhanced and it has been verified that BP with momentum is more accurate. While **(Wang et al., 2015)** this study aims to work on a new global performance index in improving power factor (PF), where different metrics are used to evaluate electrical machines, including energy efficiency Input, output power density, torque ripple, and power. The PF factor is such that the “quality” factor measures the work. The mechanical power-to-power ratio takes the "bad" factor, which is the overall engine loss, and also uses the Differential Evolution (DE) algorithm. This proposal is a useful tool for design engineers to determine the best compromised designs. While **(Wei and Batarseh, 1998)** this research aims to use the DC-DC conversion process to enhance the power of the PFC, but there are several types proposed, some of which cannot be used in the PFC. Through this research, the input characteristics of fundamental conversions are studied, focusing on intermediate input currents in discontinuous conduction mode (DCM). Buck Converter and Forward Converter were found not suitable for DCM PFC while Buck-Boost Converter and Flyback Converter were found suitable for DCM PFC due to their original characteristics.

**(Dhameliya et al., 2017)** The aim of this research is to design and develop a single-stage power factor correction system using the Arduino Uno controller to enhance the efficiency of the electrical system and improve the quality of the AC output. The proposed system uses the Arduino Uno controller to accurately correct the power factor in single-phase systems. Power factor changes are accurately detected and capacitors are energized appropriately to compensate for the active power, improving the power factor towards the module, thus enhancing system efficiency and ensuring better quality of AC output. Proteus Design Suite was used to simulate circuits and analyze electrical parameters via voltage and current measurements. This helps in testing and verifying the functionality of the automatic power factor correction system before integrating it into real devices. The automatic power factor detection and correction system provides an economical way to significantly improve the power factor, resulting in lower energy bills and improved system efficiency. While **(Al-Rakib, M.A., 2021)** this research aims to build a microprocessor-based control system to improve and develop the performance of single capacitor banks Phase. The distinctive element of this work was the use of Internet of Things (IoT) technology to monitor and operate this work from anywhere via the Internet. This work is based

on building an Arduino uno-type device to correct and increase the power factor to a predetermined value. This system uses instrument transformers to measure voltage and current and convert analog signals to digital ones. It consists of an Arduino Ono, a Wi-Fi module, sensors, corrections where necessary, remote monitoring, and load control. The system monitors the power factor in electrical systems. When the power factor decreases, automatic corrections are made to improve it. In this work, the Arduino was used to write the code, and the Proteus program was used to design and simulate the circuit. The result of this work was an improvement in the power factor to 0.85, which resulted in a savings of approximately 1.7% of the targeted energy consumption.

- **Table 1 represents the summary of the literature review:**

*Table 1: Literature Review Summary.*

<b>Reference</b>	<b>Ways to improve power factor</b>	<b>Simulation/ Experiment al</b>	<b>Microcontrolle r</b>	<b>Conclusions</b>
<b>(Mane, Sapat et al. 2020)</b>	capacitor banks	MATLAB	Arduino Uno ATmega328	A power factor of 0.9 and above automatically
<b>(Tai, 2018)</b>	capacitor banks	Proteus	Arduino Uno ATmega328	The power factor correction circuit automatically reduces the currents passing through the cables, thus reducing losses and fines and increasing the efficiency of the network, which in turn reduces the amount of energy needed to be generated in generating stations.
<b>(Ishak et al., 2015)</b>	capacitor banks	—	Arduino Uno ATmega328	If it is very close to 1, it separates the capacitor banks to eventually obtain a power

				factor that is very close to 1 and does not exceed it.
<b>(Bayindir et al., 2009)</b>	Artificial Neural Networks (ANN) and Synchronous Engines	_____	PIC 16F877	It has been shown that when ANN is integrated with a microcontroller, it leads to a fast optimization process, high accuracy, robustness, and efficiency of the system
<b>(Wang et al., 2015)</b>	_____	_____	_____	_____
<b>(Wei and Batarseh, 1998)</b>	DC-DC conversion	_____	_____	Buck Converter and Forward Converter were found to be unsuitable for DCM PFC while Buck-Boost Converter and Flyback Converter were suitable for DCM PFC due to their original characteristics
<b>(Dhameliya et al., 2017)</b>	capacitor banks	Proteus	Arduino Uno ATmega328	The power factor automatic detection and correction system provides an economical way to significantly improve the power factor, resulting in lower power bills and improving the system efficiency.
<b>(Al-Rakib, M.A., 2021)</b>	Internet of Things (IoT) technology with capacitor bank	Proteus	Arduino Uno ATmega328	The result of this work was that the power factor was improved to 0.85, saving approximately 1.7% of the target energy consumption.

This study contains a broad evaluation analysis of the work of capacitors in the power factor improvement process, which applied analysis and simulation using Proteus. Due to the ability of Proteus to deal with various microcontrollers and because it contains all the necessary electronic parts that are used in the project implementation, this study aims mainly to find cheap and accurate alternatives to obtain the best result for improving the power factor.

## CH 3 Methodology

The scope of this project is to measure, improve, control, and show the output power factor on LCD by using Arduino-Uno. Artificial intelligence used to predict the loads associated with the controller based on the daily curve and suggest turning on some loads in times of low load or stopping unnecessary loads in case of maximum load.

### 3.1 Programs we used

#### 3.1.1 Arduino IDE Program

This program was used in this work to write the operational code of the electronic circuits that serve the execution of our project, to program and control the microprocessor, and to examine whether this code is correct and error-free. This software was selected because of its easy use of simple programming language which is Arduino language based on C++ language, and many other features.



Figure 6: Arduino IDE program.

### 3.1.2 Proteus Program

This program was used in this work for the realistic simulation of the electronic department that serves the implementation of our project, where we can test, design, modify, and operate the service before it is implemented on the ground. This software can be integrated with Arduino IDE software which contributes to simulating Arduino-based automatic control systems and also provides the possibility of writing, editing and running the code.

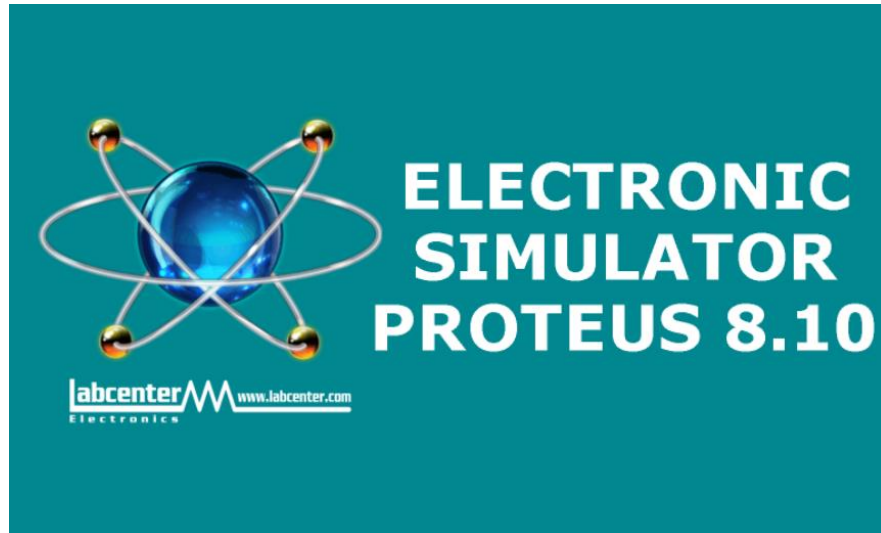

Figure 7: Proteus simulation program.

### 3.2 Power factor

What is the power factor?

It is the ratio between the real power measured in W or KW to the apparent power measured in KVA or VA. And equal the phase shift between the voltage and current. The power factor changes continuously due to the difference in the size and number of loads used simultaneously and deteriorates due to increased reactive power on loads used, affecting the system's efficiency. The decline in power factor is not a major problem for residential homes, but the most prominent problem that can occur in the industrial facilities.[1, 2]

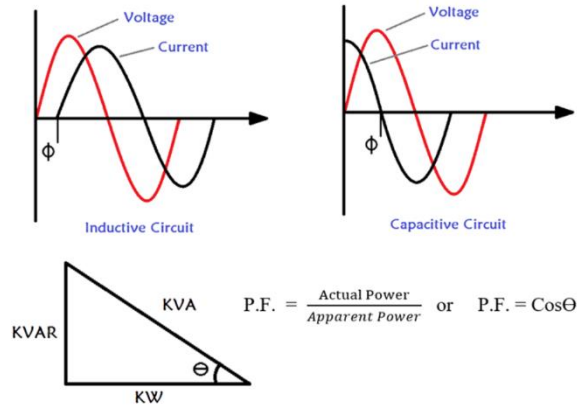

Figure 8: phase shift, and power triangle.

**Phase shift ( $\theta$ ):** It is the measurement of the time when the current lags behind the voltage in the alternating current circle, the phase angle is measured by grades or radians.

$$\theta = \theta_v - \theta_i = (\text{degree})$$

**Apparent Power (S):** the total power consumed by a specific, measured by multiply Voltage by Current a VA unit.

$$S = V \times I = (\text{VA})$$

**Active power or (Real Power): (P):** is what does the real work as machine operation and is measured by the KW unit.[1]Real power extends horizontally in the  $\hat{i}$  direction as it represents a purely real component of AC power. True power (real power) is symbolized by the letter P and is measured in the unit of Watts (W).

$$P = S \times \cos(\theta) = (\text{W})$$

**Reactive power (Q):** the power required to maintain the magnetic field in equipment such as motors and measured by the VAR unit.

$$Q = S \times \sin(\theta) = (\text{VAR})$$

**Average Power Factor ( $P_{\text{avg}}$ ):** the average value of the power factor that is calculated over a specific period of time based on several consecutive measurements of the power factor in that period. The average power factor expresses the overall efficiency of energy use in the electrical

system during that time period. It calculated by summing reactive power energy (VAR) over summing active power energy (W) then take:

$$PF_{avg} = \text{Cos} \left[ \arctan \left( \frac{\Sigma(VAR)}{\Sigma(W)} \right) \right]$$

When the power factor is lagging the power is wasted, resulting in poor reliability, safety problems, and power expenses. Since energy has a major role to play in the technology revolution, we must find appropriate solutions to the problems involved. There have been many suggestions regarding the power factor problem, the most prominent of which is power factor correction, either using the Arduino Uno or PLC and since we are currently in the era of artificial intelligence, it used in the solutions to this problem.

### 3.3 Project Components

#### 3.3.1 Indicative load:

They are mobile devices with moving parts. They operate by using a coil or coils of electrical components such as solenoids, transformers, and electric motors to produce a magnetic field. By the nature of these loads, the current consumed lags behind the voltage, forming an angle between them, as in the following picture.

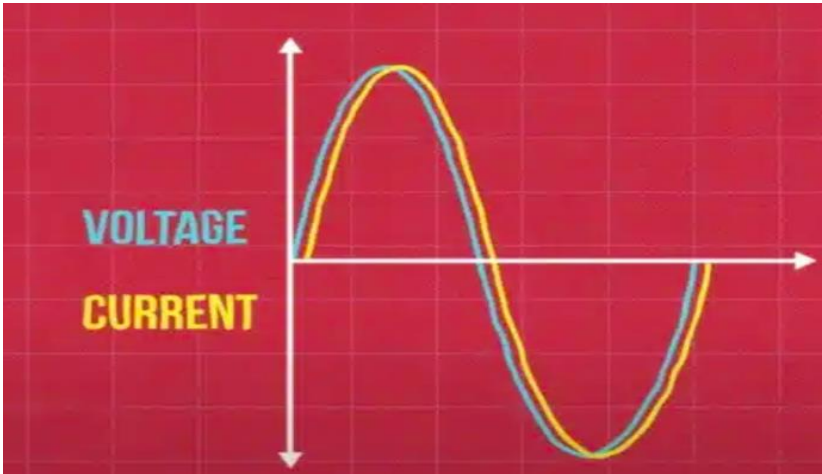

Figure 9: The current consumed lags behind the voltage.

### 3.3.2 Source:

AC voltage sources are devices or systems that generate an electrical voltage that changes periodically with time. These periodic changes are in the form of sine waves, which are the most common.

### 3.3.3 Transformers:

They are devices used to convert voltage and current in alternating electricity systems from one level to another using the principle of electromagnetic induction.

### 3.3.4 Zener diodes:

It is a special type of diode designed to allow current to flow in the opposite direction when the voltage reaches a certain value known as the zener voltage. These diodes are mainly used in voltage regulation and stabilization applications.

### 3.3.5 Zero Detection Circuits (Op-Amps):

Circuits are used to detect the moment when a voltage or current signal passes through the zero point, i.e. when its value is zero. These circuits play a vital role in a variety of electronic applications.

### 3.3.6 XOR Gate:

It is a digital logic gate that operates by touching the exception or exclusion, the working principle of an XOR gate can be understood from the truth table given below.

*Table 2: XOR Gate.*

<b>Truth Table of XOR Gate</b>		
<b>Input 1</b>	<b>Input 2</b>	<b>Output</b>
0	0	0
0	1	1
1	0	1
1	1	0

### **3.3.7 Transistors:**

They are basic electronic components used to amplify the signal. Transistors work on the principle of controlling the flow of electrical current by using small signals to control larger signals.

### **3.3.8 Capacitor banks:**

Capacitor banks play a key and important role in the project. They store electrical power in them. Induction loads consume interactive power. Capacitor banks release on time the reactive power required to compensate for their shortage, thereby correcting the power factor, due to reducing the phase shift between voltage and current.



*Figure 10: Capacitor banks.*

### **3.3.9 Relays:**

It is an electromechanical device used to switch small electrical circuits. The relay is operated by a small electrical current to open or close a larger electrical circuit. It is used in applications that require switching small to medium electrical circuits, such as automatic control systems, computers, and electronics. It differs from the contactor by not having main contacts.

### **3.3.10 ACS712ELCTR-30A-T:**

It is a high-precision current sensor used to measure electric current, manufactured by Allegro MicroSystems and based on the Hall effect. It can measure alternating or direct current up to  $\pm 30$

amps and gives an analog output of 185mV per amp. This sensor operates at a voltage of 5 volts and has a reference voltage of 2.5 volts when no current is passing.

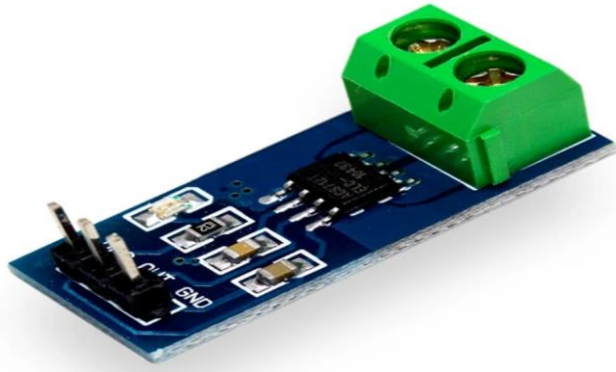

Figure 11: ACS712ELCTR-30A-T.

### 3.3.11 LCD 20×4 Screen:

A 20x4 LCD unit is commonly used in electronic and microcontroller projects. The number 20x4 indicates that the display has 20 columns and 4 rows, meaning it can display 20 characters per row across four rows.

This screen is the user interface through which it can receive alerts or display results on it, making it easier for us to monitor the project.

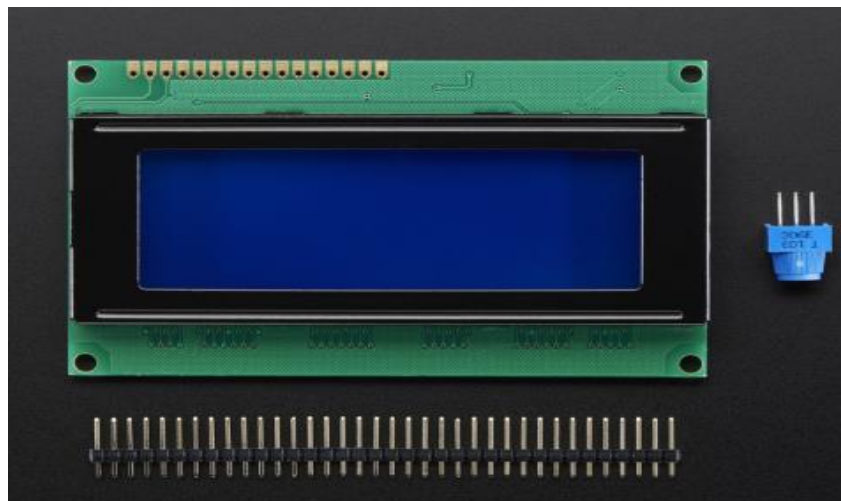

Figure 12: LCD 20×4.

### 3.3.12 Arduino Uno:

It is an open-source development platform built on easy-to-use electronic and software components, intended for beginners, hobbyists, and professionals to develop electronic projects and embedded software. The Arduino Uno is very popular due to its ease of programming and the availability of many resources and tutorials.

Arduino Uno is the main component and acts as an accurate controller of project components, controlling outputs, and can be used to make a user interface to show the most important data and output it.

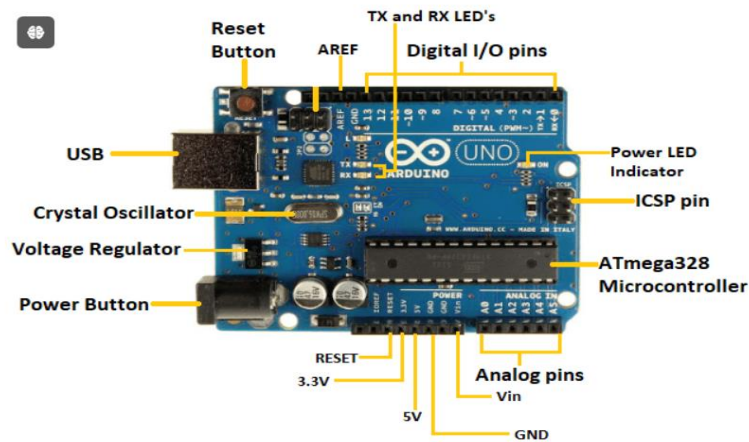

Figure 13: Arduino Uno.

### 3.4 Project work mechanism:

As mentioned earlier, the project was designed using Proteus software, and Figure 5 shows the summary of the entire project, after which it will be divided into small parts of the work to easily explain each part.

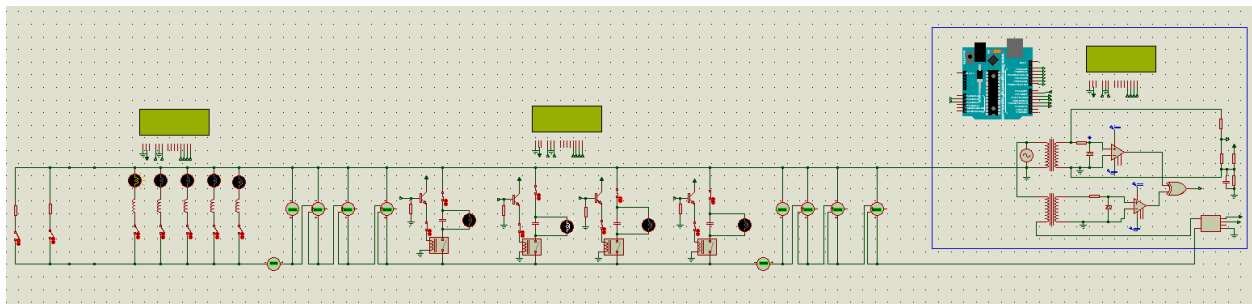

Figure 14: Project design.

### 3.4.1 Load Units

In the project, five lamps are connected as loads. Each of these lamps has an inductor coil connected in series with it. The values of these inductances are not equal. They are intentionally made differently so we can get different combinations of loads. All these loads are connected in parallel and have a switch that determines whether the load is connected or not. Using the keys we will select our preferred loading combination. Since calculating equivalent inductance follows the same rule as resistors, adding inductance in parallel will reduce the total load inductance value.

In addition, when loads start operating without the presence of coils, the angle between voltage and current is zero. However, when coils are present for each lamp, an angle begins to form between voltage and current, and its amount increases when the load increases.

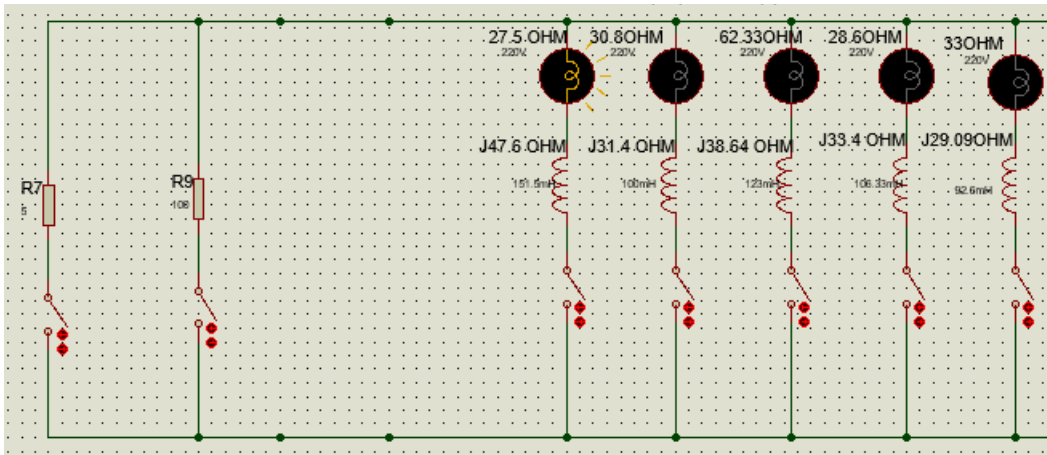

Figure 15: Load units.

So, if loads are turned on in this system, the capacitor bank controls and improves the power factor. The value of both resistance and Inductor for each load is (R1=27.5 $\Omega$ , L1=151.5mH)(R2=30.8 $\Omega$ , L2=100mH)(R3=62.33 $\Omega$ , L3=123mH)(R4=28.6 $\Omega$ , L4=106.33mH) (R5=33 $\Omega$ , L5=92.6mH).

In addition, a resistor of 100 ohms was placed as a resistive load only to check that the power factor is unity, and a resistance of 5 ohms was also placed to check the presence of a high current that is not needed, that is, if the system consumes more than 25A The capacitor bank is disconnected for protection.

### 3.4.2 Phase shift display circle

A sinusoidal AC source of 312 V, 50 Hz is used. The RMS value of the source is about 220V. Two step-down transformers are used to step down the high voltage of 220 volts to a lower voltage of about 7 volts to measure the voltage and current. This step down is necessary because both voltage and current are fed to the two Op-Amps and the voltage required to operate the Op-Amps is very low (5V). Two transformers are called potential transformer (PT) and current transformer (CT). The PT is connected in parallel with the source and measures the voltage. To transformer ratio To convert 220V to 7V, the inductance value of the primary and secondary windings of the transformer has been changed. For PT, the primary inductance is set to 0.9H and the secondary inductance is set to 0.001H. This is done using a trial-and-error method.

The current is measured using a CT. This transformer is connected to the circuit in series. Thus the current flowing through the transformer will induce a voltage in the primary coil and eventually in the secondary coil. The current value is too low. So we kept the transformer ratio as 1 by setting the inductance value of both coils to 0.001H. The secondary side outputs of both PT and CT are fed to two “zero detection circuits”.

Then use the “zero detection circuit” to detect the zero crossing point of any signal. This circuit is made using Op-Amp. We used the LM741 Op-Amp model in the project. We used two zero-detection circuits. One is for voltage and the other is for current. In both zero detection circuits, Op-Amps are used in comparison mode.

The inverted terminals are grounded. So the voltages on the non-inverting terminals are greater than zero, and the Op-Amps will give 5V whenever they are at the output terminal. When the voltages are less than zero, i.e. in the negative half cycle, the Op-Amps output will be zero. Thus Op-Amps can detect zero crossings of both voltage and current. Now the Op-Amps will give us a square pulse of 5V when the voltage and current are in the positive half cycle. If there is a phase difference between the current and voltage, the square pulses will not start at the same time. The phase angle can be determined from the delay between the onset of the squared current and voltage pulses. To measure this delay, square pulses of voltage and current are passed through the XOR gate.

Two Zener diodes, which have a reverse breakdown voltage of 5 V, are connected across each op-amp. This is done to limit the voltage level to 5V across the Op-Amps. When the voltage is higher than 5V, a Zener diode acts as a voltage regulator and provides a constant voltage of 5V. The Op-Amps are limited to 5V because the Arduino runs on 5V.

The output terminals of the Op-Amps are connected to two XOR gate terminals. The working principle of the XOR gate can be understood from the truth table shown below.

When the outputs of both Op-Amps are zero, the XOR inputs are zero. So the output of XOR is zero. When the voltage or current of either is higher than zero, the corresponding Op-Amp output is 5V, i.e. one of the XOR inputs is 5V. So the XOR output is 5V. Then when the other signal becomes more than zero, the other Op-Amp starts giving 5V to the other input of the XOR making the output of the XOR zero. Thus for the phase difference part, XOR gives a square pulse of 5V.

Finally, the XOR output is fed into the Arduino to then be used to measure the phase shift between voltage and current through a specific code.

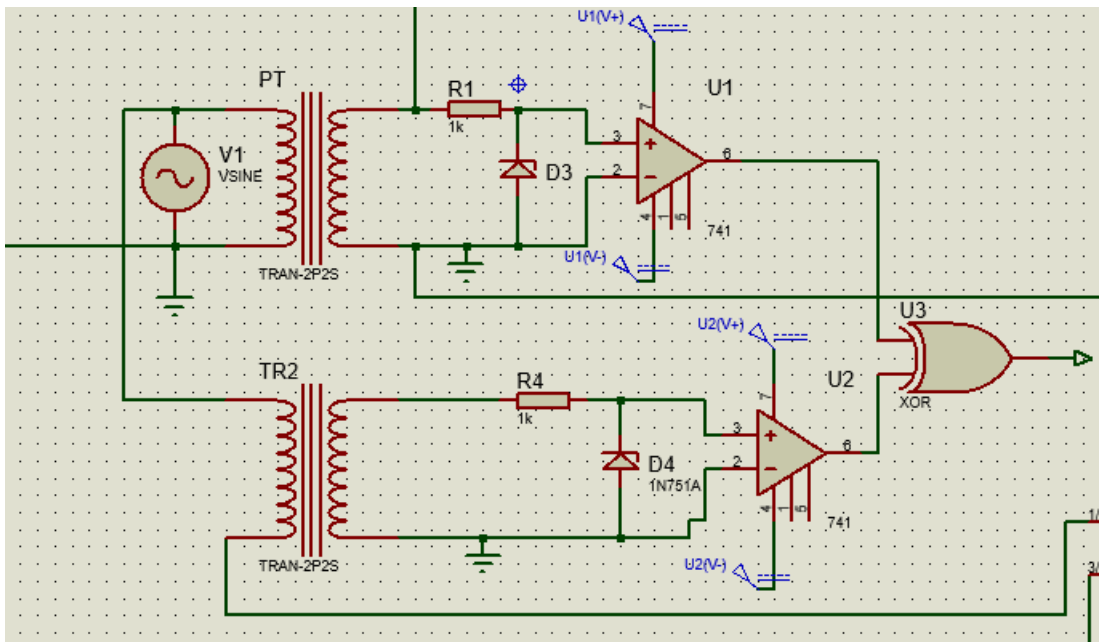

Figure 16: Phase shift display circle

### 3.4.3 Capacitor Banks Units

Here four capacitors are connected to the loads for power factor correction. Capacitors are operated by relays that are energized by transistors. All transistor collectors are connected to a 5V supply and the emitters are connected to the four relays. The base transistors (Q1, Q2, Q3, Q4) are connected to the Arduino pins D1, D2, D3, D4. When the Arduino supplies 5 volts to either pin, the transistor base connected to that opposite pin gets 5 volts. Thus the emitter and collector of that transistor are shorted and 5V is passed to the relay connected to that transistor. As a result, the relay is energized and the capacitor corresponding to that relay is connected to the circuit. In this way, all four capacitors are controlled.

The capacitor values are chosen as follows: C1=50uF, C2=25uF, C3=38.5uF, C4=44uF. These values are chosen to have the advantage of increasing the capacitance value by 10uF at each step. When power factor correction is not needed, pins D4, D3, D2, and D1 are set to 0000 and 0V is supplied to the base of the transistors. The transistor remains open-circuited and no current flows through the transistor to the relay. So the relay is not energized and the capacitors are disconnected. For D4 D3 D2 D1 = 0001, a 50uF capacitor is connected in parallel with the circuit. When D4 D3 D2 D1 = 0010, the 25uF capacitor is connected in parallel with the circuit. For D4 D3 D2 D1 = 0011, 50uF and 25uF capacitors are connected in parallel with the circuit. In this way, there are 16 different groups starting from 0000 to 1111.

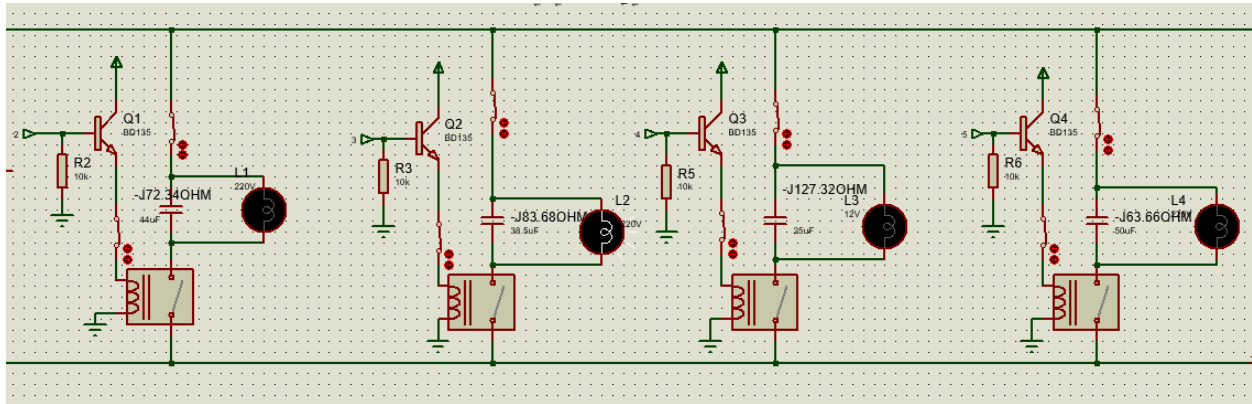

Figure 17: Capacitor Units.

In addition to placing lamps parallel to the capacitors, the lamps operate when the capacitor connected to them operates, and thus it is distinguished which of the capacitors is active.

### 3.4.4 Current and Voltage Measurement Circuit

- Voltage is measured by using resistors with specific values, as in picture No. 14, in order for the voltage to decrease and the microprocessor to be able to read it and then display it on the LCD screen with the original voltage value before placing the resistors via a specific code for that.
- The current is also measured through the current sensor ACS712ELCTR-30A-T, where the sensor is connected to 5 volts in order for it to work, and the inputs and outputs to be measured are connected through the designated paths on the sensor. The microcontroller works to convert the sensor's output from voltage to current so that every 185mV represents one ampere, and Then display the current value on the LCD screen.

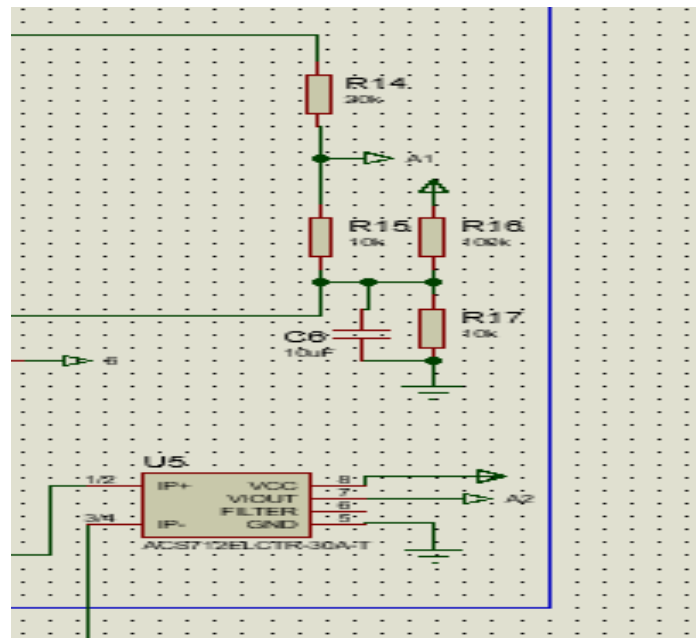

Figure 18: Current and voltage measurement circuit.

### 3.4.5 Arduino Connection

This project used “Arduino Uno” to measure the phase difference between current and voltage, to measure the power factor from the phase angle, to display the power factor value, and to decide which combination of the capacitors should be used to improve the power factor if it falls below a preset value. To do all these things, the Arduino needs to collect data from the circuit and send data to the LCD and capacitor banks.

The measuring and decision-making procedures will be discussed in the coding part. Here we will explain the hardware connections only. The connection of different pins of the Arduino is as follows:

**Pin 0:** The output of the XOR gate is connected to this pin. This pin measures the duration of the output pulse of the XOR gate and then converts it to phase angle.

**Pin 1-4:** These 4 pins are connected to the base of 4 transistors. These pins are used to turn on the capacitors.

**Pin 8-13:** These pins are connected to the LCD and are used to control the LCD.

**Pin A0:** This pin is used to measure the current in the circuit. Pin A0 is an analog input pin. It can measure values starting from 0 to 1023. The voltage from the CT is divided using a voltage divider and then passed to the pin A0. If there's any change in the current, the voltage will change. Thus the change in current can be detected using this pin. This pin is mainly used to sense the open circuit situation. Whenever the circuit has no load, there will be no current flow. Thus voltage at pin A0 will be zero. Thus the Arduino can know about the open circuit situation.

**Pin A1:** This pin is special for reading the load voltage value.

**Pin A2:** This pin is special for reading the current consumed by loads when they operate.

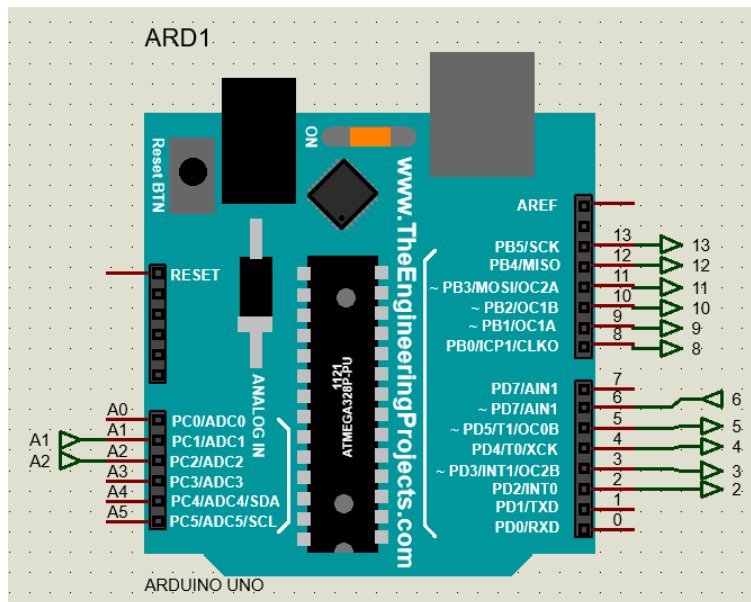

Figure 19: Arduino circuit.

### 3.5 Project code:

```
//-----decalre Voids for measuring
and calculating parameters

void Measure_Current();//I

void Measure_Voltage();//V

void Measure_Power_Factor();//PF

void Calculate_Apearent_power();//S

void Calculate_Reactive_power();//Q

void Calculate_Active_power();//P

void Check ();

//-----decalre Voids for No load
detect

void No_Load_Check ();

void Only_Capacitive_Print();

void Only_Inductive_Print();

void No_Load_Print();

//-----decalre Void for Over or
Low Voltage or Over Current

void Over_Voltage ();

void Over_Current ();

//-----decalre Voids for
Monotoring

void Print();

void print_power();

void print_Start();

void print_unity();

//-----decalre Voids for correction
power factor

void CB_Print();

void Correction(int x);

//-----include libraries

#include "EmonLib.h" // Include Emon Library

#include<LiquidCrystal.h>

//-----LCD Pins
```

```
LiquidCrystal LCD(13,12,11,10,9,8);

//_____
__power factor, Angle, Phase Shift

int dur = 0;//to measure phase shift

float pfavg =0.0 ;//to Calculate power factor avarage

float PF, Angle;//to calculate power factor & Angle

int ReadDur = 6;//Connect Phase Shift sensor with pin
6 of Arduino to Calculate Power Factor

//_____
__Voltage

float Voltage; //to measure AC Voltage

const int volt = A1;//Connect Voltage sensor with pin
A1 of Arduino

EnergyMonitor emon1; //Create an instance

int offsetvoltage = 2500; //no of samples

//_____
__Current

float AC_Current;//to measure AC Curenre

const int Sensor_Pin = A2; //Connect current sensor
with pin A2 of Arduino

int sensitivity = 66; // Calbration for Current (use 100
for 20A Module and 66 for 30A Module)

//_____
__Power

float S; //to calculate aparent power VA

float Power;///to calculate active power W

float Reactive_Power; //to calculate Reactive Power
(Q)VAR

//_____
__Energy

float accumulated_active_Energy = 0;//to calculate
Active Energy W.h

float accumulated_Reactive_Energy = 0;//to calculate
Reactive Energy VAR.h
```

```

//float timeElapsed = 0; //to Calculate Runing time
//long previousMillis = 0;//to Calculate Runing time
//_____
__No Load
int Out_No_Load=0;//to detect No load state
//_____
__Power Factor Correction
int Case = 0;//for capacitor to change from case to
case
int R1 = 2;//Connect Relay with pin 2 of Arduino to
add or remove Capacitor
int R2 = 3;//Connect Relay with pin 3 of Arduino to
add or remove Capacitor
int R3 = 4;//Connect Relay with pin 4 of Arduino to
add or remove Capacitor
int R4 = 5;//Connect Relay with pin 5 of Arduino to
add or remove Capacitor
//float Time = 0.0;
unsigned long start_Time;
unsigned long end_Time;
unsigned long elapsed_Time;
void setup()
{
Serial.begin(9600);
start_Time = millis(); // Record start time in
milliseconds
emon1.voltage(volt, 166, 1.7);
LCD.begin(20, 4);
pinMode(volt, INPUT);
pinMode(Sensor_Pin, INPUT);
pinMode(ReadDur, INPUT);
pinMode(R1, OUTPUT);
pinMode(R2, OUTPUT);
pinMode(R3, OUTPUT);
pinMode(R4, OUTPUT);
digitalWrite(R1, LOW);

```

```

digitalWrite(R2, LOW);
digitalWrite(R3, LOW);
digitalWrite(R4, LOW);
}
void loop()
{
Out_No_Load=0;
Case=0;
Correction(Case);
Check ();
Over_Voltage ();
Over_Current ();
No_Load_Check ();
print_Start();
delay (1000);
LCD.clear ();
while(Angle<-24 && Angle>-80)//this for Correction if
PF less than 0.92 laging or angle <-24
{
while (1)
{
Case++;
if (Case>15)
{
Case=0;
break;
}
Print ();
CB_Print ();
LCD.setCursor(0,3);
LCD.print(" ");
LCD.setCursor(0,3);
LCD.print("Correcting~PF");

```

```

Correction(Case);
delay (100);
Check ();
Over_Voltage ();
Over_Current ();
No_Load_Check ();
if((Angle>=-24) && (Angle<=-18))
{
break;
}
while(Angle>-18 && Angle<0)
{
Print ();
CB_Print ();
LCD.setCursor(0,3);
LCD.print("      ");
LCD.setCursor(0,3);
LCD.print("Correcting~PF");
Case++;
if (Case>15)
{
Case=0;
break;
}
Correction(Case);
delay (100);
Check ();
Over_Voltage ();
Over_Current ();
No_Load_Check ();
if((Angle>=-24) && (Angle<=-18))
{
break;
}
}

}
if((Angle>=-24) && (Angle<=-18))
{
break;
}
if (Case==0 || (Angle>=-24) && (Angle<=-18))
{
break;
}
while (Angle>-18 && Angle <=0)
{
LCD.clear ();
Print();
LCD.setCursor (0,3);
LCD.print (" PF Close1 lag");
delay (500);
print_unity();
Check ();
Over_Voltage ();
Over_Current ();
No_Load_Check ();
if((Angle<=-24) && (Angle>=-18))
{
break;
}
}
while (Angle<18 && Angle >=0)
{
LCD.clear ();
Print();
}
}

```

```

delay (500);
LCD.setCursor (0,3);
LCD.print (" PF Close1 lead");
delay (500);
print_unity();
Check ();
Over_Voltage ();
Over_Current ();
No_Load_Check ();
if((Angle<=-24) && (Angle>=-18))
{
break;
}
while((Angle>=-24) && (Angle<=-18))
{
print_power();
Check ();
Over_Voltage ();
Over_Current ();
No_Load_Check ();
if(Angle<-24 || Angle>-18)
{
break;
}
Serial.println("after finished (1) loop ");
}
Serial.println("after finished main loop ");
}
void Measure_Voltage ()
{
// Measure Voltage
for (int i =0 ; i<5 ;i++)
{
emon1.calcVI(20, 2000); // Calculate all. No.of half
wavelengths (crossings), time-out
Voltage = emon1.Vrms; //extract Vrms into Variable
}
}
void Measure_Current()
// Measure Current
unsigned int temp = 0;
float maxpoint = 0;
for (int i = 0; i < 500; i++)
{
if (temp = analogRead(Sensor_Pin), temp > maxpoint)
{
maxpoint = temp;
}
}
float ADCvalue = maxpoint;
double eVoltage = (ADCvalue / 1024.0) * 5000; //
Gets you mV
double Current = ((eVoltage - offsetvoltage) /
sensitivity);
AC_Current = (Current) / (sqrt(2));
}
void Measure_Power_Factor()
{
//Measure instantaneous Power factor
dur = pulseIn(ReadDur, HIGH);
Angle = dur * 0.018; //time to angle (in degree)
convert
Angle = Angle-90; // (-90) is for offsetting the angle
PF = cos(Angle*0.0174533); //angle conversion from
degree to radian, then PF calculation
//Measure Power factor avarage

```

```

pfavg = cos(atan
(accumulated_Reactive_Energy/accumulated_active_
Energy) );
}

void Calculate_Aparent_power()
{
// Measure Aparent Power (p)
S = Voltage * AC_Current;
}

void Calculate_Active_power()
{
// Measure Active Power (p)
Power = S*PF;
// Measure Energy (W.h meter)
//long currentMillis = millis();

//timeElapsed = ((currentMillis - previousMillis) /
1000.0); // Time in seconds

unsigned long Loop_Time=millis();

end_Time = millis();

elapsed_Time = (end_Time - start_Time);

accumulated_active_Energy += (Power *
(elapsed_Time/1000)*10) / 3600.0; // Watt-hours

//previousMillis = currentMillis;
Serial.print("Elapsed time: ");
Serial.print((elapsed_Time/1000)*10);
Serial.println(" Seconds");
Serial.print("Time = ");
Serial.print((Loop_Time/1000)*10);
Serial.println(" Seconds");
start_Time = millis();
}

void Calculate_Reactive_power()
{
// Measure Reactive Power (Q)

```

```

Reactive_Power = S*sin(acos(PF));
if (Angle>0)
{
Reactive_Power =Reactive_Power *-1;
}
// Measure Energy (VAR.h meter)
accumulated_Reactive_Energy += (Reactive_Power
*(elapsed_Time/1000)*10) / 3600.0; // VAR-hours
}

void Check ()
{
Measure_Current();
Measure_Voltage ();
Measure_Power_Factor();
Calculate_Aparent_power();
Calculate_Reactive_power();
Calculate_Active_power();
}

void print_power()
{
LCD.setCursor(0,0);
LCD.print("      ");
LCD.setCursor(0,0);
LCD.print("V = ");
LCD.print(Voltage);
LCD.setCursor(9,0);
LCD.print(" V");
LCD.setCursor(12,0);
LCD.print("|");
LCD.setCursor(13,0);
LCD.print("Correct");
LCD.setCursor(0,1);
LCD.print("      ");

```

```

LCD.setCursor(0,1);
LCD.print("I = ");
LCD.print(AC_Current);
LCD.setCursor(9,1);
LCD.print(" A");
LCD.setCursor(12,1);
LCD.print("|");
LCD.setCursor(13,1);
LCD.print(" Done");
LCD.setCursor(0,2);
LCD.print("      ");
LCD.setCursor(0,2);
LCD.print("PF= ");
LCD.print(PF,2);
if (Angle>5)
{
LCD.print("lead");
}
else if (Angle<-5)
{
LCD.print("lag");
}
else
{
LCD.print("unity");
}
LCD.setCursor(12,2);
LCD.print("|");
LCD.setCursor(13,2);
LCD.print("in Case");
LCD.setCursor(0,3);
LCD.print("      ");
LCD.setCursor(0,3);

LCD.setCursor(0,1);
LCD.print("PFavg= ");
LCD.print(pfavg,2);
LCD.setCursor(12,3);
LCD.print("|");
LCD.setCursor(13,3);
LCD.print("  ");
LCD.setCursor(13,3);
LCD.print("  ");
LCD.print (Case);
delay (500);
LCD.clear ();
LCD.setCursor(0,0);
LCD.print("      ");
LCD.setCursor(0,0);
LCD.print("P = ");
LCD.print(Power);
LCD.setCursor(14,0);
LCD.print("W "); //unit for the power to be measured
long Time = ((millis()*4.7966)/1000);
LCD.print (Time);
LCD.setCursor(0,1);
LCD.print("      ");
LCD.setCursor(0,1);
LCD.print("PE = ");
LCD.print(accumulated_active_Energy, 1);
LCD.setCursor(14,1);
LCD.print("Wh "); //unit for the energy to be
measured
LCD.setCursor(0, 2);//-----
-----
LCD.print("      ");
LCD.setCursor(0,2);
LCD.print("Q = ");

```

```

LCD.print(Reactive_Power);
LCD.setCursor(14,2);
LCD.print("VAR");
LCD.setCursor(0,3);
LCD.print(" ");
LCD.setCursor(0,3);
LCD.print("QE = ");//-----
-----
LCD.print(accumulated_Reactive_Energy, 2);
LCD.setCursor(14,3);
LCD.print("VAR.h");
}
void print_Start()
{
LCD.setCursor(0,0);
LCD.print(" ");
LCD.setCursor(0,0);
LCD.print("V = ");
LCD.print(Voltage);
LCD.setCursor(9,0);
LCD.print(" V");
LCD.setCursor(12,0);
LCD.print("|");
LCD.setCursor(0,1);
LCD.print(" ");
LCD.setCursor(0,1);
LCD.print("I = ");
LCD.print(AC_Current);
LCD.setCursor(9,1);
LCD.print(" A");
LCD.setCursor(12,1);
LCD.print("|");
LCD.setCursor(13,1);

```

```

LCD.print("Start");
LCD.setCursor(0,2);
LCD.print(" ");
LCD.setCursor(0,2);
LCD.print("PF= ");
LCD.print(PF,2);
if (Angle>5)
{
LCD.print("lead");
}
else if (Angle<-5)
{
LCD.print("lag");
}
else
{
LCD.print("unity");
}
LCD.setCursor(12,2);
LCD.print("|");
LCD.setCursor(0,3);
LCD.print(" ");
LCD.setCursor(0,3);
LCD.print("PFavg= ");
LCD.print(pfavg,2);
LCD.setCursor(12,3);
LCD.print("|");
LCD.setCursor(13,3);
LCD.print(" ");
delay (500);
LCD.clear ();
LCD.setCursor(0,0);
LCD.print(" ");

```

```

LCD.setCursor(0,0);
LCD.print("P = ");
LCD.print(Power);
LCD.setCursor(14,0);
LCD.print("W "); //unit for the power to be measured
LCD.setCursor(0,1);
LCD.print("      ");
LCD.setCursor(0,1);
LCD.print("PE = ");
LCD.print(accumulated_active_Energy, 1);
LCD.setCursor(14,1);
LCD.print("Wh "); //unit for the energy to be
measured
LCD.setCursor(0, 2);//-----
-----
LCD.print("      ");
LCD.setCursor(0,2);
LCD.print("Q = ");
LCD.print(Reactive_Power);
LCD.setCursor(14,2);
LCD.print("VAR");
LCD.setCursor(0,3);
LCD.print("      ");
LCD.setCursor(0,3);
LCD.print("QE = ");//-----
-----
LCD.print(accumulated_Reactive_Energy, 2);
LCD.setCursor(14,3);
LCD.print("VAR.h");
}
void print_unity()
{
LCD.setCursor(0,0);
LCD.print("      ");

```

```

LCD.setCursor(0,0);
LCD.print("V = ");
LCD.print(Voltage);
LCD.setCursor(9,0);
LCD.print(" V");
LCD.setCursor(12,0);
LCD.print("|");
LCD.setCursor(0,1);
LCD.print("      ");
LCD.setCursor(0,1);
LCD.print("I = ");
LCD.print(AC_Current);
LCD.setCursor(9,1);
LCD.print(" A");
LCD.setCursor(12,1);
LCD.print("|");
LCD.setCursor(13,1);
LCD.print("Unity");
LCD.setCursor(0,2);
LCD.print("      ");
LCD.setCursor(0,2);
LCD.print("PF= ");
LCD.print(PF,2);
if (Angle>5)
{
LCD.print("lead");
}
else if (Angle<-5)
{
LCD.print("lag");
}
else
{

```

```

LCD.print("unity");
}
LCD.setCursor(12,2);
LCD.print("|");
LCD.setCursor(0,3);
LCD.print(" ");
LCD.setCursor(0,3);
LCD.print("PFavg= ");
LCD.print(pfavg,2);
LCD.setCursor(12,3);
LCD.print("|");
LCD.setCursor(13,3);
LCD.print(" ");
delay (500);
LCD.clear ();
LCD.setCursor(0,0);
LCD.print(" ");
LCD.setCursor(0,0);
LCD.print("P = ");
LCD.print(Power);
LCD.setCursor(14,0);
LCD.print("W "); //unit for the power to be measured
LCD.setCursor(0,1);
LCD.print(" ");
LCD.setCursor(0,1);
LCD.print("PE = ");
LCD.print(accumulated_active_Energy, 1);
LCD.setCursor(14,1);
LCD.print("Wh "); //unit for the energy to be
measured
LCD.setCursor(0, 2);//-----
-----
LCD.print(" ");

```

```

LCD.setCursor(0,2);
LCD.print("Q = ");
LCD.print(Reactive_Power);
LCD.setCursor(14,2);
LCD.print("VAR");
LCD.setCursor(0,3);
LCD.print(" ");
LCD.setCursor(0,3);
LCD.print("QE = ");//-----
-----
LCD.print(accumulated_Reactive_Energy, 2);
LCD.setCursor(14,3);
LCD.print("VAR.h");
}
void Print()
{
LCD.clear ();
LCD.print(" ");
LCD.setCursor(0,0); //setCursor(x,y) x=column
y=row
LCD.print(" ");
LCD.setCursor(0,0);
LCD.print("I=");
LCD.print(AC_Current);
LCD.print("A ");
LCD.print("<"); //unit for the current to be measured
LCD.print(Angle,2);
if (Angle>5)
{
LCD.print("lead");
}
else if (Angle<-5)
{

```

```

LCD.print("lag");
}
else
{
LCD.print("unity");
}
LCD.setCursor(0,1);
LCD.print("      ");
LCD.setCursor(0,1);
LCD.print("PF= ");
LCD.print(PF,2);
LCD.setCursor(0,2);
LCD.print("      ");
LCD.setCursor(0,2);
LCD.print("PFavg= ");
LCD.print(pfavg,2);
}
void CB_Print()
{
LCD.setCursor(17,3);
LCD.print("C");
LCD.print(Case);
}
void No_Load_Check ()
{
while(AC_Current<0.20 && Power<35 &&
Reactive_Power<35)
{
Case=0;
Correction(Case);
LCD.clear();
No_Load_Print();
delay(500);
}
}

```

```

Check ();
if (AC_Current>=0.20 || Power>=35 ||
Reactive_Power>=35)
{
Out_No_Load++;
break;
}
}
while((Angle<-80 && Angle>-90) && (Power<70 &&
Reactive_Power>70))//work Q-----
{
Case=0;
Correction(Case);
LCD.clear();
Only_Inductive_Print();
delay (500);
Check ();
if (Angle<=80 && Angle>=-80)
{
Out_No_Load++;
break;
}
}
while ((Angle>80 && Angle<90) && (Power<70 &&
Reactive_Power>70))//work Q-----
{
Case=0;
Correction(Case);
LCD.clear();
Only_Capacitive_Print();
delay (500);
Check ();
if (Angle<=80 && Angle>=-80)
{

```

```

Out_No_Load++;

break;

}

}

if ((AC_Current<0.20 && Power<35 &&
Reactive_Power<35)

|| ((Angle>80 && Angle<90) && (Power<70 &&
Reactive_Power>70))

|| ((Angle<-80 && Angle>-90) && (Power<70 &&
Reactive_Power>70)))

{

No_Load_Check ();

}

}

void No_Load_Print()

{

LCD.clear();

Print ();

LCD.setCursor(0,3);

LCD.print("          ");

LCD.setCursor(0,3);

LCD.print(" NO LOAD CONNECTED ");

}

void Only_Inductive_Print()

{

LCD.clear();

Print();

LCD.setCursor(0,3);

LCD.print("          ");

LCD.setCursor(0,3);

LCD.print(" Warning  ");

}

void Only_Capacitive_Print()

{

LCD.clear();

Print();

LCD.setCursor(0,3);

LCD.print("          ");

LCD.setCursor(0,3);

LCD.print(" Warning  ");

}

void Correction(int x)

{

if(x==1)

{

digitalWrite(R1, HIGH);

digitalWrite(R2, LOW);

digitalWrite(R3, LOW);

digitalWrite(R4, LOW);

}

else if(x==2)

{

digitalWrite(R1, LOW);

digitalWrite(R2, HIGH);

digitalWrite(R3, LOW);

digitalWrite(R4, LOW);

}

else if(x==3)

{

digitalWrite(R1, HIGH);

digitalWrite(R2, HIGH);

digitalWrite(R3, LOW);

digitalWrite(R4, LOW);

}

else if(x==4)

{

digitalWrite(R1, LOW);

```

```

digitalWrite(R2, LOW);
digitalWrite(R3, HIGH);
digitalWrite(R4, LOW);
}
else if(x==5)
{
digitalWrite(R1, HIGH);
digitalWrite(R2, LOW);
digitalWrite(R3, HIGH);
digitalWrite(R4, LOW);
}
else if(x==6)
{
digitalWrite(R1, LOW);
digitalWrite(R2, HIGH);
digitalWrite(R3, HIGH);
digitalWrite(R4, LOW);
}
else if(x==7)
{
digitalWrite(R1, HIGH);
digitalWrite(R2, HIGH);
digitalWrite(R3, HIGH);
digitalWrite(R4, LOW);
}
else if(x==8)
{
digitalWrite(R1, LOW);
digitalWrite(R2, LOW);
digitalWrite(R3, LOW);
digitalWrite(R4, HIGH);
}
else if(x==9)

```

```

{
digitalWrite(R1, HIGH);
digitalWrite(R2, LOW);
digitalWrite(R3, LOW);
digitalWrite(R4, HIGH);
}
else if(x==10)
{
digitalWrite(R1, LOW);
digitalWrite(R2, HIGH);
digitalWrite(R3, LOW);
digitalWrite(R4, HIGH);
}
else if(x==11)
{
digitalWrite(R1, HIGH);
digitalWrite(R2, HIGH);
digitalWrite(R3, LOW);
digitalWrite(R4, HIGH);
}
else if(x==12)
{
digitalWrite(R1, LOW);
digitalWrite(R2, LOW);
digitalWrite(R3, HIGH);
digitalWrite(R4, HIGH);
}
else if(x==13)
{
digitalWrite(R1, HIGH);
digitalWrite(R2, LOW);
digitalWrite(R3, HIGH);
digitalWrite(R4, HIGH);
}

```

```

}
else if(x==14)
{
digitalWrite(R1, LOW);
digitalWrite(R2, HIGH);
digitalWrite(R3, HIGH);
digitalWrite(R4, HIGH);
}
else if(x==15)
{
digitalWrite(R1, HIGH);
digitalWrite(R2, HIGH);
digitalWrite(R3, HIGH);
digitalWrite(R4, HIGH);
}
else
{
digitalWrite(R1, LOW);
digitalWrite(R2, LOW);
digitalWrite(R3, LOW);
digitalWrite(R4, LOW);
}
}

void Over_Voltage ()
{
while (Voltage>230 || Voltage<210)
{
Case =0;
Correction(Case);
LCD.clear();
Print();
if (Voltage > 230)
{
LCD.setCursor(0,3);
LCD.print("      ");
LCD.setCursor(0,3);
LCD.print(" Over Voltage ");
}
else if (Voltage<210)
{
LCD.setCursor(0,3);
LCD.print("      ");
LCD.setCursor(0,3);
LCD.print(" Under Voltage ");
}
delay (500);
Check ();
if (Voltage>230 || Voltage<210)
{
Over_Voltage ();
}
if (Voltage<230 && Voltage>210)
{
break;
}
}
}

void Over_Current ()
{
while (AC_Current>25 )
{
Case =0;
Correction(Case);
LCD.clear();
Print();
LCD.setCursor(0,3);

```

```
LCD.print("      ");          break;
LCD.setCursor(0,3);          }
LCD.print(" Over Current ");  }
delay (500);                 }
Check ();
if (AC_Current<=25)
{
```

## CH 4 Results and Analysis

In this project, a complete design for the process of improving the PF was made, and the values of the angle between the voltage and the current at all existing loads were obtained and displayed on the LCD screen, in addition to the PF value. The value of the currents consumed by the loads was also obtained, and the voltage value was also displayed for them, all types of power and energy were also produced, including real power, reactive power, real energy, and reactive energy, also, of course, this project showed how the optimization process proceeds precisely, as the capacitor bank works on adding each capacitor separately until the PF value is improved to become 0.95 and above in order to obtain the best results, here it is presented in the form of tables how the PF and phase shift change before and after the optimization process with the change of loads, in addition to comparing the values of both real power and reactive power before and after the optimization process.

In this stage, the loads were connected in several ways, as follows:

**Case 1:** A resistive load has been connected with a value of  $(100 \Omega)$ .

**Case 2:** Are inductive load with the value of  $(27.5 + j 47.5) \Omega$ .

**Case 3:** It is a load equivalent to two loads  $(27.5 + j 47.5)$ ,  $(30.8 + j31.4)$  connected in parallel with the value of  $(15.17 + j 19.396) \Omega$ .

**Case 4:** It is a load equivalent to three loads  $(27.5 + j 47.5)$ ,  $(30.8 + j31.4)$ ,  $(62.33+j38.64)$  connected in parallel with the value of  $(12.73 + j 13.6266) \Omega$ .

**Case 5:** It is a load equivalent to four loads  $(27.5 + j 47.5)$ ,  $(30.8 + j31.4)$ ,  $(62.33+j38.64)$   $(28.6 + j 33.4)$  connected in parallel with value of  $(8.82 + j 9.685) \Omega$ .

**Case 6:** It is a load equivalent to five loads  $(27.5 + j 47.5)$ ,  $(30.8 + j31.4)$ ,  $(62.33+j38.64)$   $(28.6 + j 33.4)$ ,  $(33+ j 29.09)$  connected in parallel with value of  $(6.99 + j 7.297) \Omega$ .

#### 4.1 Phase shift value and power factor before the optimization process

➤ The result was obtained as in the following table:

Table 3: Phase shift value and power factor before the optimization process.

# Case	Resistance( $\Omega$ )	Inductor(mH)	phase shift( $\theta^\circ$ )	Power Factor	Capacitor Bank
1	100	0	-0.95	1	0000
2	27.5	151.5	-60.35	0.49	0000
3	15.17	61.74	-52.51	0.61	0000
4	12.73	43.37	-47.72	0.67	0000
5	8.82	30.83	-48.87	0.66	0000
6	6.99	23.23	-47.48	0.68	0000

In this table, the result shows before power factor improvement to notice the change in the power factor value., it was clearly observed that when the load increased, the power factor decreased.

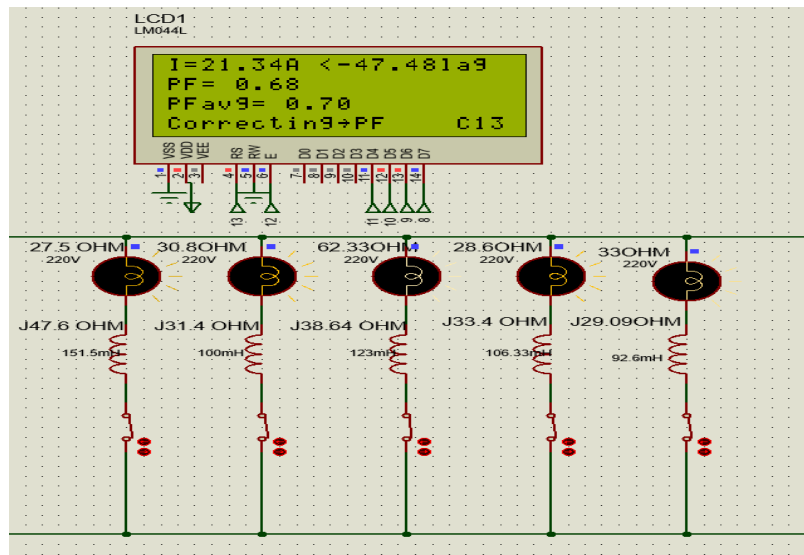

Figure 20: Phase shift value and power factor before the optimization process at case 6

In this picture, all loads were operated within case number six without activating the capacitors, and we notice that the power factor value is low by 0.68.

## 4.2 Phase shift value and power factor after the optimization process

➤ The result was obtained as in the following table:

Table 4: Phase shift value and power factor after the Correction process.

# Case	Resistance( $\Omega$ )	Inductor(mH)	phase shift( $\theta^\circ$ )	Power Factor	Capacitor Bank
1	100	0	-0.95	1	0000
2	27.5	151.5	-23.07	0.92	0100
3	15.17	61.74	-23.06	0.92	1010
4	12.73	43.37	-21.57	0.93	1100
5	8.82	30.83	-21.56	0.93	1011
6	6.99	23.23	-19.95	0.94	1111

At this stage, the capacitor bank was activated, and it was noted that when the load was gradually increased, the power factor value began to decrease, but the capacitor bank worked to raise the power factor value until it reached this range (0.92 - 0.95). From here we conclude the importance of connecting the capacitor in parallel with the load in order to improve the power factor.

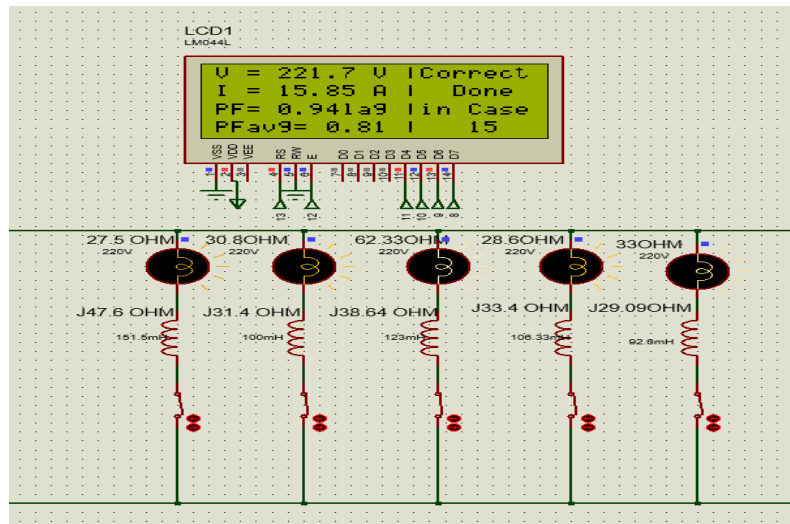

Figure 21: Phase shift value and power factor after the Correction process at case 6

In this picture, all loads were operated within case number six, in addition to activating the capacitors, so the power factor value was improved from 0.68 to 0.94.

### 4.3 The value of real power, reactive power, real energy, and reactive energy before the optimization process

➤ The result was obtained as in the following table:

Table 5: The value of real power, reactive power, real energy, and reactive energy before the Correction process.

# Case	V(V)	I(A)	real power(W)	reactive power(VAR)	real energy(W.h)	reactive energy(VAR.h)
1	221.8	2.2	487.24	0	48.7	0
2	221.8	3.98	449.05	766.63	42.4	72.44
3	221.8	8.84	1227.34	1559.19	105.9	147.13
4	221.8	11.67	1773.47	1914.68	150.0	181.08
5	221.8	16.53	2491.79	2756.6	221.2	260.31
6	221.8	21.34	3193.2	3496.02	310.6	330.2

In this table, the result before improving the power factor shows the value of P and Q according to the following equations that explain the relationship of the phase shift with the change in the values of both P and Q.

$$P = V \cdot I \cdot \cos(\text{phase shift}).$$

$$x = V \cdot I \cdot \sin(\text{phase shift}).$$

It turns out at this stage that the angle value is relatively large at each load, which results in a large increase in the Q value.

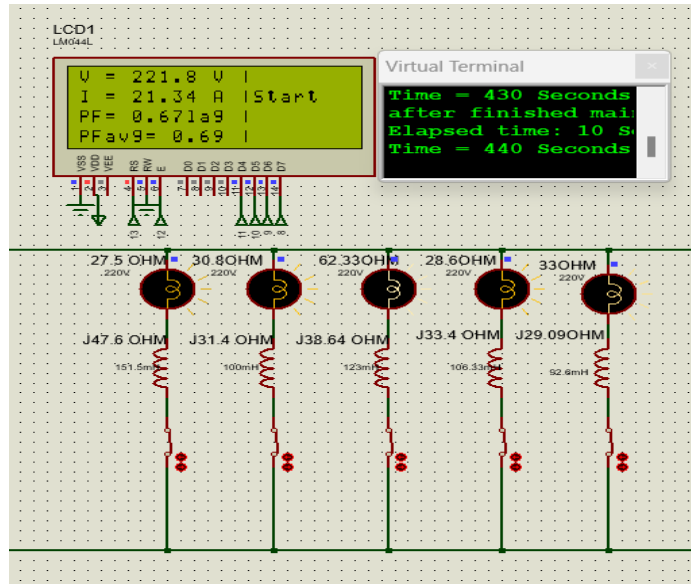

Figure 22: Value the current, power factor, and voltage before setting the capacitor bank to case 6

In this picture, the capacitors were disconnected, all loads were operated in case number six, and the current, power factor and voltage values were displayed.

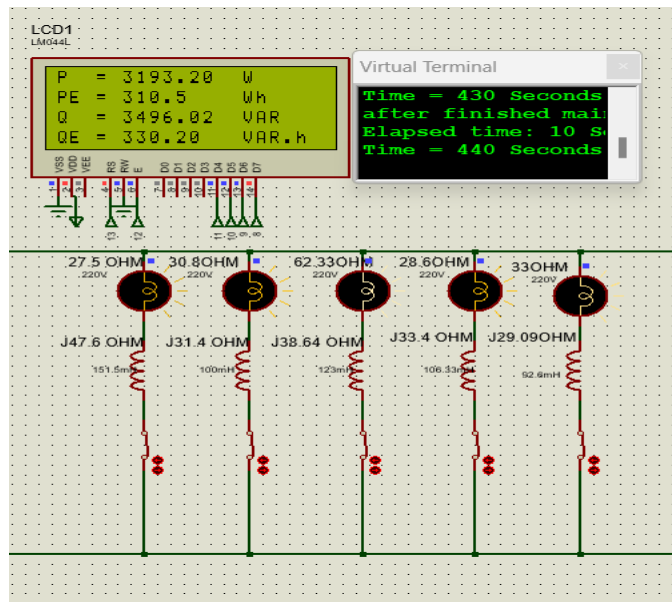

Figure 23: Real energy and reactive energy before activating the capacitor bank for case 6

In this picture, the capacitors were disconnected from the system, and all loads were also turned on, as in case number six. We ran the system for 7 minutes, after which the values of both the real energy and the reactive energy were taken. There is also a screen to display the time in seconds and another screen to display the rest of the values.

#### 4.4 The value of real power, reactive power, real energy, and reactive energy after the optimization process

➤ The result was obtained as in the following table:

Table 6: The value of real power, reactive power, real energy, and reactive energy after the optimization process.

# Case	V(V)	I(A)	real power(W)	reactive power(VAR)	real energy(W.h)	reactive energy(VAR.h)
1	221.8	2.2	487.24	0	48.7	0
2	221.8	2.2	449.05	189.15	38.6	13.5
3	221.8	6.2	1227.34	523.81	97.5	43.07
4	221.8	8.58	1773.47	690.59	140.0	52.63
5	221.8	12.08	2491.79	990.19	208.8	140.09
6	221.8	15.85	3306.73	1192.85	291.8	150.81

We note in this table, with the capacitor bank in particular, the value of P and Q, and according to the following equations that explain the relationship of the phase shift with the change in the values of both P and Q

$$P = V \cdot I \cdot \cos(\text{phase shift}).$$

$$Q = V \cdot I \cdot \sin(\text{phase shift}).$$

We notice at this stage that the value of the angle becomes relatively lower with each load, and after adding a capacitor in parallel with the load, this leads to a clear decrease in the value of Q, and this matter is taken into account after the optimization process.

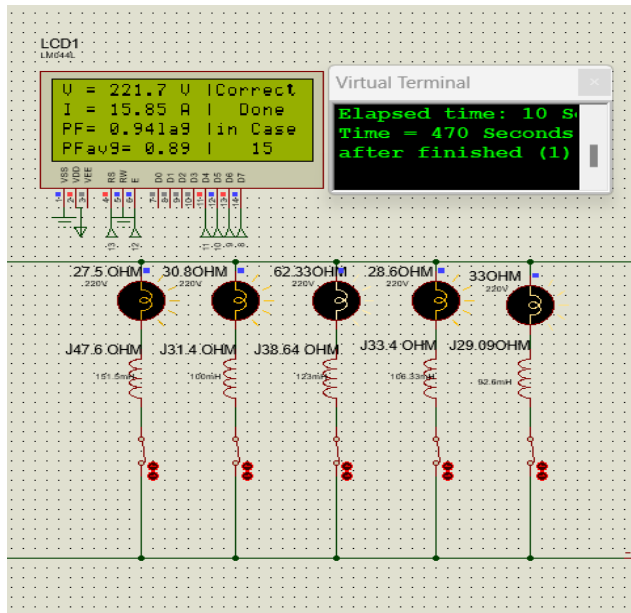

Figure 24: Value the current, power factor, and voltage after setting the capacitor bank to case 6

In this picture, the capacitors are activated and all loads are operating in state number six, and the current, power factor, and voltage values are displayed.

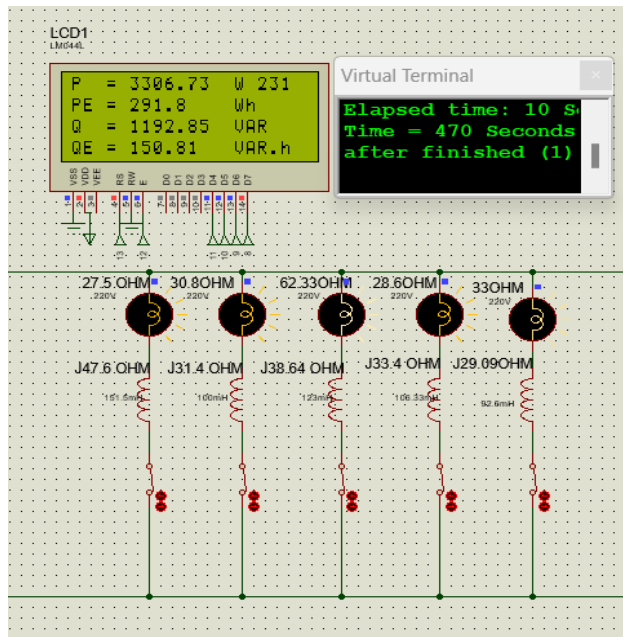

Figure 25: Real energy and reactive energy after activating the capacitor bank for case 6

In this picture, the capacitors in the system were activated and all loads were turned on, as in case number six. We ran the system for 7 minutes, after which the values of both real energy and reactive energy were taken. There is also a screen to display the time in seconds and another screen to display the rest of the values.

The average power factor is considered one of the most important elements within any industrial facility. In this project, it was calculated by taking all the power factor values when operating each load and taking the average of these values, so the average power factor is taken after a long period of time, as it depends on the amount of real energy and reactive energy, it can be calculated through the following equation:

$$PF_{avg} = \cos(\tan^{-1}(\frac{\text{reactive energy}}{\text{real energy}}))$$

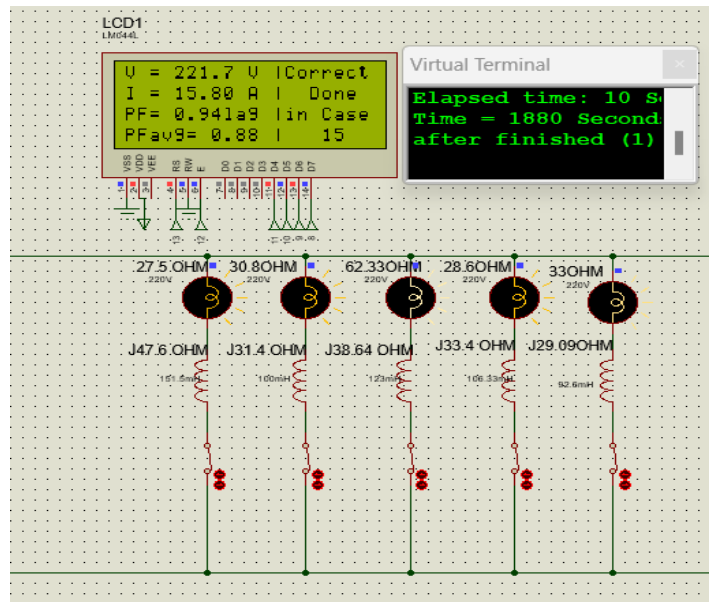

Figure 26:  $PF_{avg}$  a period of time of 30 minutes

In this picture, the first load, which represents case No. 2, was operated for five minutes, after which the load was gradually increased every five minutes until it reached case No. 6. In total, a period of time of 30 minutes was waited, and an average power factor value of 0.88 was produced.

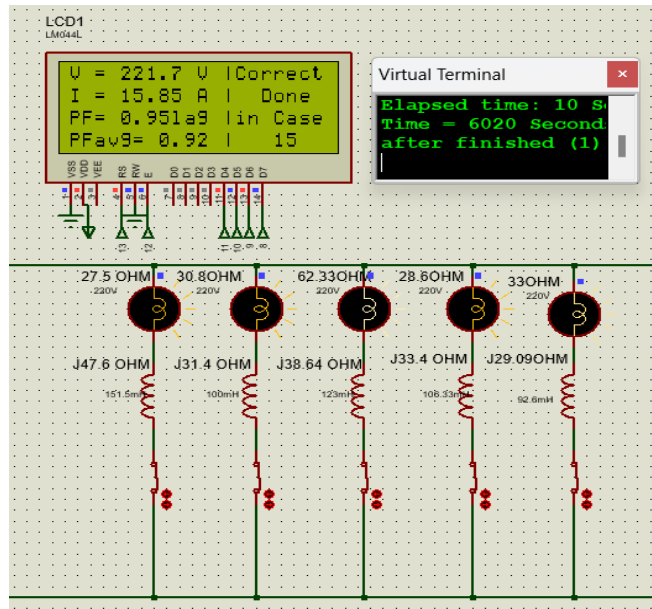

Figure 27: PF.avg a period of time of 100 minutes

In this picture, an excellent average power factor value of 0.92 was obtained. All loads were operated in case No. 6 for 100 minutes, which is equivalent to 6020 seconds, as displayed on the time screen.

#### 4.5 Waveforms of voltage and current and the time difference between them

In this part, we have four cases in which the voltage waveform is displayed, which represents the yellow color, the current waveform, which represents the blue color, and the form of the time difference signal between the voltage and current, which represents the red color, and it expresses the phase shift. The first case shows the shapes of these waves without operating any load, while the second case shows the shapes of the waves with a 100-ohm load operating, which represents Case 1 of the load operating cases. The third case, shows the waveforms of five loads together, which falls within Case 6 of the load operating cases, but with separation operation of the capacitors finally, the fourth case, which is the same as the third case, but in which the waveforms are displayed while the operation of the capacitors is activated.

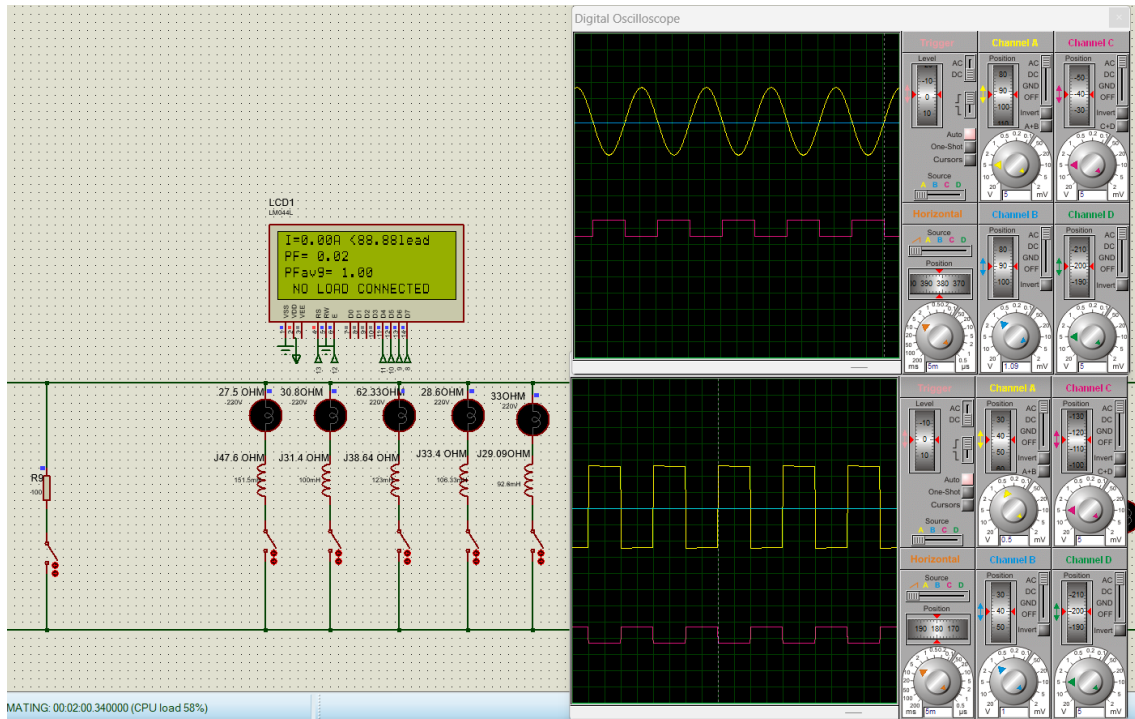

Figure 28: Waveforms with all loads separated.

In this picture, all loads have been disconnected, as shown, the current is zero compared to the voltage as shown on the oscilloscope screen.

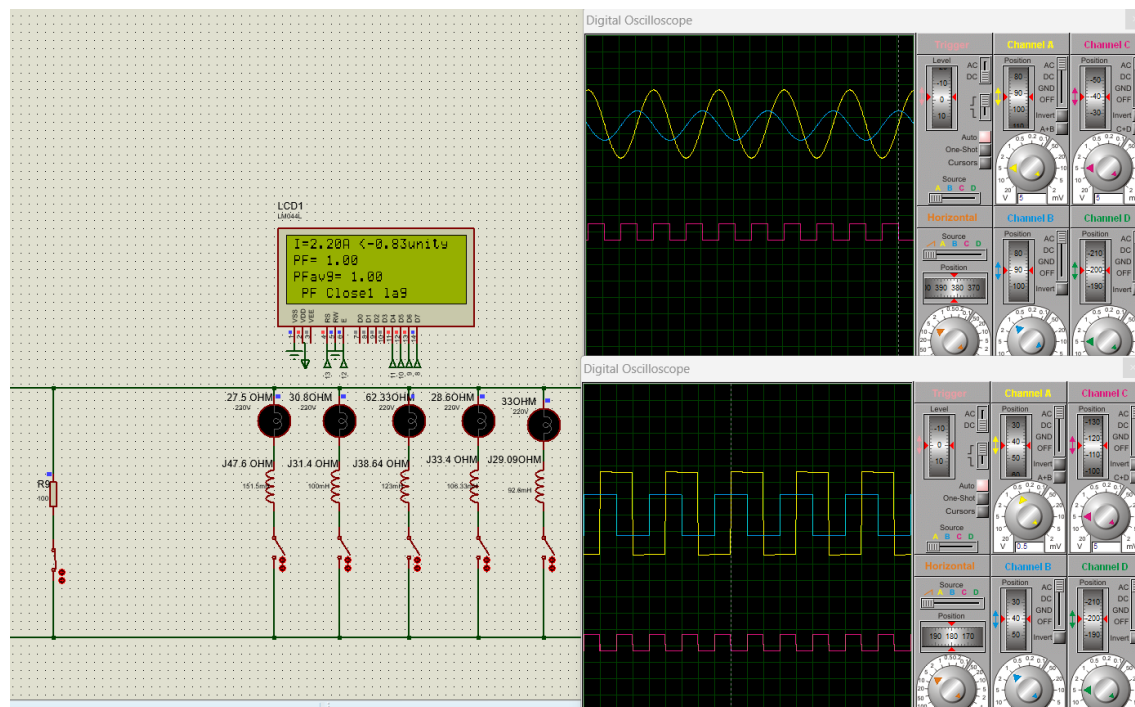

Figure 29: Waveforms with 100-ohm operation.

In this picture, the 100-ohm resistor was turned on alone, so the power factor value should be 1, and the phase shift between the voltage signal and the current signal should be zero, but it turns out in this picture that there is a difference of 90 degrees, and this difference is the result of the transformer files for measuring the current. This problem has been modified in the code inside the Arduino, the phase shift became almost zero, as shown on the LCD screen

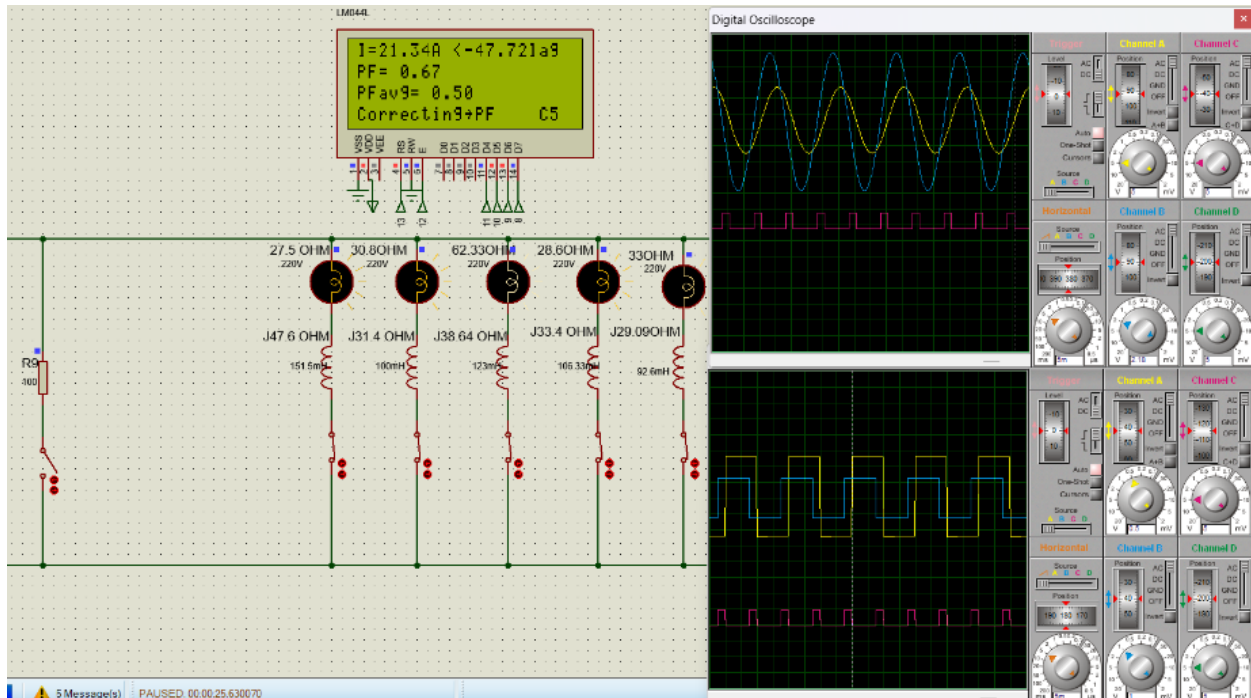

Figure 30: Waveforms with five loads running and capacitors disconnected.

In this picture, five loads were turned on with the capacitors disconnected, and we notice the formation of a small time difference between the voltage wave and the current, which creates a high phase shift, which leads to a small power factor, as shown in the picture on the LCD screen.

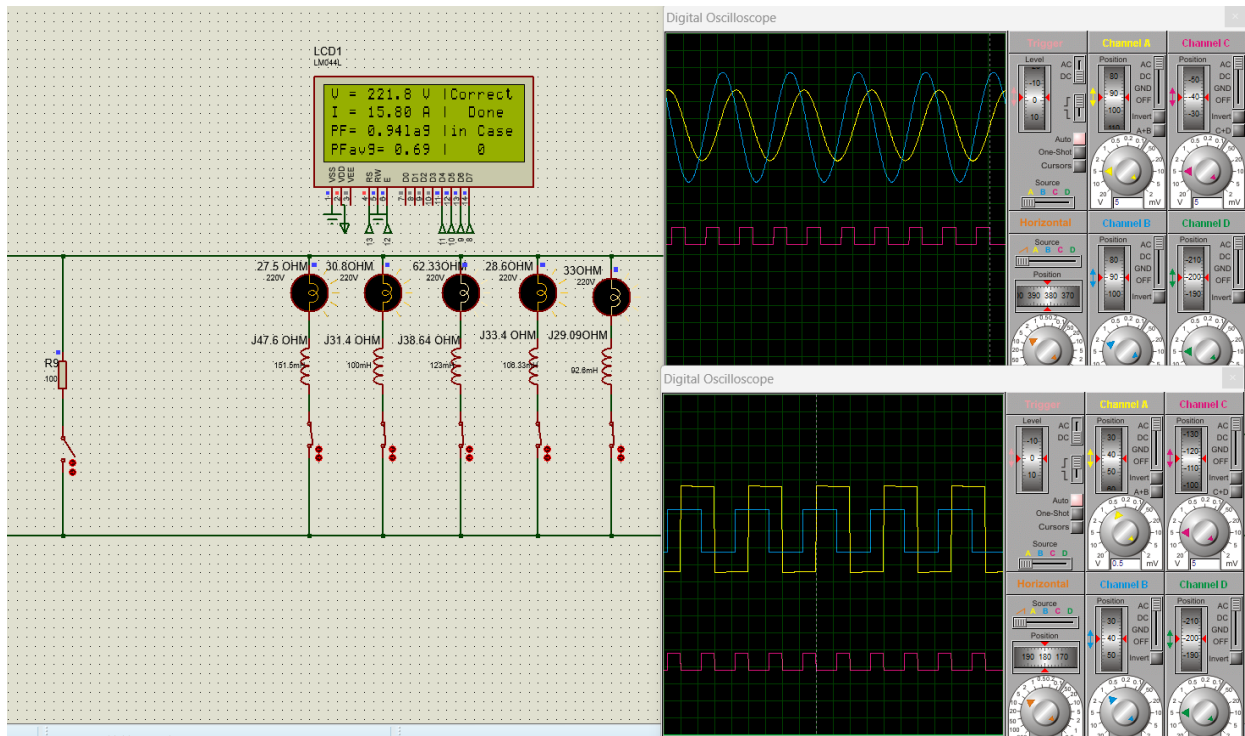

Figure 31: Waveforms with five loads on and capacitors activated.

In this case, the five loads were turned on and the capacitors were activated. We notice in this image that the time difference between the voltage and the current in this case is greater than in the previous case, resulting in a lower phase shift and a higher power factor, as displayed on the LCD screen.

## CH 5 Conclusions and Recommendation

### 5.1 Conclusion

In conclusion, a circuit was designed to measure the phase shift between voltage and current. Artificial intelligence was used to automatically improve the power factor by utilizing capacitor banks and monitoring the improvement process through Simulink, which was implemented using Proteus software. This setup allows us to display readings and results on the screen, showing the capacitors involved in the improvement process clearly.

In this work, reactive power was reduced, which in turn reduces the current, while maintaining a constant value for real power. This work demonstrated real energy, reactive energy, and the average power factor, which is an important measure of energy efficiency in electrical systems.

Improving the power factor plays a crucial role in energy conservation. After reviewing the simulation results using Proteus software, the power factor was enhanced to (0.92-0.95) by adding capacitor banks as needed. After testing the existing capacitor banks, the appropriate bank is selected for optimization, which is reflected on the screen.

This intelligent power factor control system has numerous features, including an accurate measurement system for voltage, current, real, reactive, and apparent power, providing essential data for analyzing and improving system performance. Additionally, it includes an automatic control system that adapts to changes in electrical loads to maintain optimal energy efficiency. The improvement sequence is visually displayed, allowing us to monitor the system's status by showing the results on the screen.

Furthermore, this system reduces the reliance on importing devices, thereby lowering costs since local production is cheaper than importing.

This project incorporates artificial intelligence, which is a key driver for development and competition in a rapidly changing world. It opens new horizons for success and innovation in various fields of life. We see this system as an important step toward achieving sustainability goals and improving energy efficiency across different sectors.

## **5.2 Recommendation**

When using this project or completing it to benefit from it in an industrial facility, contactors must be placed instead of existing relays because relays do not operate under high loads and are easily damaged. Also, improve measurement accuracy by adding filters to get rid of harmonics, in addition to establishing a periodic maintenance system to improve the reliability of the system. It is possible to continue development by researching the latest technologies in the field of artificial intelligence and power factor control.

## **5.3 Future Work**

Work on Project 2 will involve completing various tasks not completed in Project 1, starting with the selection and purchase of each of the following parts (Source, Transformers, Zener Diodes, Op-Amps, XOR Gate, Transistors, Capacitor Banks, Relays, ACS712ELCTR-30A -T, 20x4 LCD, Arduino Uno) and design a board on which the parts of the entire project will be mounted.

In addition, the project can be developed to automatically detect and identify expected faults during system operation without the need to disconnect any loads or shut down the system such as a defect in one of the capacitors. This enhances the reliability of the system and thus increases efficiency. We will use special loads found in university laboratories under the supervision of our professor so that we can display the best results.

And it also works to predict the maintenance date for each capacitor bank by analyzing data previously stored in the system in addition to the ability of artificial intelligence to know the age of the capacitor bank, which helps it give a warning that the capacitor has reached the time to change it, to avoid extinguishing it.

Artificial intelligence also provides the ability to improve the distribution of capacitor banks in an effective manner in a faster time based on the load curve information that is stored in the system's

memory and its prediction of the nature of the load and the appropriate capacitors to activate, thus further enhancing the system's performance.

Using artificial intelligence also enables efficient improvement of capacitor bank distribution based on load curve information stored in the system's memory and its prediction of the load nature and suitable capacitors for activation, thereby enhancing system performance significantly.

Accurately measuring electrical parameters such as voltage (V), current (I), power factor (PF), calculating power (P, Q, S), and energy (E) using appropriate formulas, along with mastering communication skills to clearly and concisely transmit results to stakeholders, are essential aspects.

## References

- Mane, S., et al. (2020). Microcontroller-based automatic power factor correction system for power quality improvement. 2020 International Conference for Emerging Technology (INCET), IEEE.
- TAYE, A. 2018. Design and simulation of automatic power factor correction for industry application. international journal of engineering technologies and management research, 5, 10-21.
- ISHAK, N. H., ZAINODIN, M. N., SALIM, N. A., TWON TAWI, F. M. & MOHD SAOD, A. H. 2015. A design of an automatic single-phase power factor controller by using Arduino uno Rev-3. Applied Mechanics and Materials, 785, 419-423.
- BAYINDIR, R., SAGIROGLU, S. & COLAK, I. J. E. P. S. R. 2009. An intelligent power factor corrector for a power system using artificial neural networks. 79, 152-160.
- WANG, Y., IONEL, D., DORRELL, D. G. & STRETZ, S. J. I. T. O. M. 2015. Establishing the power factor limitations for synchronous reluctance machines. 51, 1-4.
- WEI, H. & BATARSEH, I. Comparison of basic converter topologies for power factor correction. Proceedings IEEE Southeastcon'98'Engineering for a New Era', 1998. IEEE, 348-353.
- DHAMELIYA, R., DOMADIYA, K., MIYANI, P., SAVALIYA, H., JARIWALA, P. J. I. J. O. A. E. & DEVELOPMENT, R. 2017. Automatic power factor control using Arduino Uno. 4.
- AL RAKIB, M.A., NAZMI, S., IMAM, M.H., UDDIN, M.N. 2021. Arduino-based automatic power factor control. INTERNATIONAL JOURNAL OF SMART GRID, 5.
- <https://www.helioselectric.net/blog/power-factor-efficiency-costs>
- <https://automation-electric.com/product/automatic-capacitor-bank-for-power-factor-correction-50-kvar/>
- <https://circuitdigest.com/tutorial/what-is-power-factor-and-how-it-affects-your-energy-bills>