

An-Najah National University



Faculty of Engineering & Information Technology

Computer of Engineering Department

Graduation Project 2

ArtiMixer

Groub members

Ethar Suwan & Shahd Lubbadeh

Supervised by:

Dr Aladdin Masri

Presented in partial fulfilment of the requirements for

Bachelor degree in Computer Engineering.

July/2023

Contents

Acknowledgment:.....	4
DISCLAIMER	4
Abstract:.....	5
Chapter 1: Introduction.....	6
1.1 Statement of the problem:	6
1.2 Project Objective:	6
1.3 Scope of the work:.....	7
1.4 Significance or importance of your work	8
Chapter 2:	9
Constraints, Standards and Earlier course work.....	9
2.1 Constraints	9
2.2 Earlier coursework.....	10
Chapter 3: Literature Review.....	11
Chapter 4: Methodology	13
4.1 Overview of The System.....	13
4.2 Hardware Components and Implementation:.....	14
4.3 Software:	22
Chapter 5: Results and Analysis	24
Chapter 6: Conclusions and Recommendations.....	26
References	27

Table of Figures:

Figure 1 Arduino Mega.....	15
Figure 2 Arduino Uno	15
Figure 3 L298N Driver.....	17
Figure 4 Dc gear motor	17
Figure 5 10ml syringe.....	18
Figure 6 LCD 16*2	18
Figure 7 Keypad 4*4	19
Figure 8 Esp 8266 Wi-Fi Module	19
Figure 9 DC Gear Motor 25GA370.....	20
Figure 10 Ultrasonic Sensor.....	19
Figure 11 IR Obstacle Avoidance Sensor Module	21
Figure 12 Mixing Arm	20
Figure 13 application,1	23
Figure 14 application,2.....	23
Figure 15 application, 3.....	24
Figure 16 machin photo	25

Acknowledgment:

We would like to express our gratitude to our families, Dr. Alaa Masri, and our instructors for their unwavering support and guidance throughout this project. Their belief in us and their valuable input were instrumental in our success. We also appreciate the contributions of our peers and the resources we consulted. Thank you all for being part of this journey

DISCLAIMER

This report was written by Ethar Suwan and Shahd Lubbadah at the Computer Engineering Department, Faculty of Engineering, An-Najah National University. It has not been altered or corrected, other than editorial corrections, as a result of assessment and it may contain language as well as content errors. The views expressed in it together with any outcomes and recommendations are solely those of the student(s). An-Najah National University accepts no responsibility or liability for the consequences of this report being used for a purpose other than the purpose for which it was commissioned.

Abstract

A color mixer device that allows users to enter RGB (Red, green, blue) values of their desired color via a keypad or mobile application. The mobile app will enable users to take a picture of the color or upload an image from their gallery and scan the color needed. Arduino Mega and UNO will be used as the microcontrollers of this mixing device, the two microcontrollers will communicate serially, Arduino Mega will be the master one which will receive the commands from the user and orchestrate the different parts of the device, the Arduino UNO will be responsible of controlling the motors that are used to pull the colors depending on the commands that it receives from the Mega.

When a command of mixing with the RGB values as parameters is received by the Mega microcontroller will convert the RGB values to CMYK (Cyan, Magenta, Yellow, Black) values and calculate the right amount of each color to produce the desired color, then checking if there is enough amount of color in each cup also it will check if a cup is inserted to generate the output color in, if the checks are passed, Arduino Mega will send command to the Arduino UNO to control the dc gear motors that is attached to syringe using Hbridge to pull the required amount from every color and then emptying the syringe in the output cup. A motor will then mix the CMYK colors to produce the desired result.

This device will benefit artists and art students by reducing the time and cost of color mixing. Additionally, it will eliminate the need to mix multiple shades of a color to achieve the right hue. Unlike existing paint-mixing machines that are expensive and often lack mixing features, this device will be designed specifically for artists and art students, providing a cost-effective alternative to traditional paint-mixing machines.

Chapter 1: Introduction

1.1 Statement of the problem

The problem is the time-consuming and costly process of color mixing for artist and art students. existing paint-mixig machines are often expensive and lake the necessary features for artistic color mixing.

In this project we aim to develop a color mixer device that is affordable, user-friendly, and designed specifically for artistic uses.

The device will allow users to input RGB Values through keypad or mobile application then a series of actions will occur from converting the RGB to CMYK and then calculate the appropriate amount of each color required to produce the desired color.

and then each syring (Cyan syring, yellow syring, Magenta syringe, and Black syring) will be filled with the calcualted amount of color and then emptying these syring into the output cup and mixing it with the mixing feature.

So this project focused on these problem:

- Time-Consuming color mixing: Traditional methods of color mixing for artist anf art students can be a time-consuming process.
- Costly color mixing: Existing paint-mixing machines can be expensive, making them unaffordable for artists and art students.
- Lake of mixing feature: Many existing color mixing machine only produced the colors needed for the desired color without providing mixing these produced color together.
- The waste of color shades: Many artists and art student had to try multiple time and wast paint in order to get to the right shade.

Overall, this project aims to provide a more efficient and cost-effective solution for artists and art students.

1.2 Project Objective

This project aims to develop a color mixer device that specifically targets the needs :of artists and art students. And it aims to achieve the following

1. Time-saving color mixing: The device should significantly reduce the time required to get the color needed compared to traditional methods and even other devices it aimes to enhanced the throughput of the time. By automating

the process of calculating, filling, emptying then mixing the color that will make achieving the desired color more efficiently.

2. Cost-effective solution: The project aims to provide an affordable alternative to the expensive paint-mixing machines currently available in the market. By utilizing to available components such as arduino mega, H-bridge, Dc gear .motors, syringes, etc. And they are all cost-effective and accessible
3. Enhanced mixing features: Unlike existing machine that lack the mixer feature where most of the existing machines depends on manual mixing of the color, in this project we provided a mixer that mix the CMYK colors after being produced.
4. Accurate color calculation: The device accurately calculate the right amounts of Cyan, Magenta, Yellow, and Black colors required to achieve the desired color. And control the syringes to fill the right amount of color and then emptying it on the output cub.
5. Improve user experience: The device aims to provide a user-friendly interface, whether through keypad or a mobile application by choosing the image from gallery or take a picture and then using the cursor choose the color the user want, which make it easy for the user to input the desired color.

With these objectives the device reduced the time and cost associated with color mixing, providing accurate representation, and offering a user-friendly device for the users.

1.3 Scope of the work

The color mixing device project include the following:

1. Design and development of the color mixer device: The project involve designing and developing a functional color mixer device that allows users to input RGB values, scan the color on image through the mobile application, converting RGB to CMYK values, and accurately calculate and produce the right amount of cyan, magenta, yellow, and black to get the desired shade.
2. Integration with Arduino mega microcontroller: The device utilize arduino mega as the microcontroller to receive the Rgb value, converting it to CMYK, then controlling the dc motor to fill and empty the syringe, and there is a motors to make a up/down movement and rotating movement (more on that through the report).

3. Mobile application development: The project include the development of a mobile application that enables users to choose an image through gallery or take a picture, then choose the spot they want its color and the CMYK value will be sen through esp 8266 wifi module to the arduino.

The project dose not deal with:

1. Detailed mechanical design of the motors or microcontroller, etc: While the project involves the utilization of dc motor to control filling and emptying the syringe, rotate and up/down movement, it dose not go in details into the design of the motors. The focus is on the overall functionality and integration of the device rather than the specific mechanical engineering aspects.
2. Economic analysis: While the project may consider the cost-effectiveness of the device to mach the targeted users budget, it dose not undertake an extensive economic analysis or cost estimation beyond using affordable components.

1.4 Significance or importance of your work

1. Customized Color Production: The device allow the user to easily reproduce specific color by simply enter the RGB value.
2. Cost saving: The automated color mixing process can save time and color waste comparing with manual mixing methods.
3. Accessibility and Convenience: The mobile application enables users to easily select colors from images using their smartphones. This feature makes the device accessible to more users artist, student, and individuals who wants to experiment with color mixing.

Chapter 2: Constraints, Standards and Earlier course work

2.1 Constraints

During the design and testing of the device, several constraints were encountered, which influenced the decision-making process. The following constraints were identified:

1. **Cost:** the idea is based on implementing an affordable machine for students and artist, and in order to make this a reality we have to go through a lot of challenges to find an affordable tool and supplement. The initial design of the machine was based on using pumps for color dispensing. So after testing several affordable pumps, it was found that they either lacked sufficient pulling power to draw the color and there was leakage when the pumps are not connected to the power because of their centrifugal force. So finally we decided to switch to motors and syringes.
2. **Size and Design:** since the device aims to help artists and students who probably have limited working space, the device was designed with the smallest possible size (32 cm x 32 cm x 50 cm) which puts some challenges on syringes and other parts setup, also the syringes base rotation movement forced us to use another microcontroller in addition to the master one to reduce the number of wires that will be moved from the top rotating base to the stable base.
3. **Communication Channel with the Mobile Application:** for the communication with the mobile the Wi-Fi protocol was asked to be used.

These constraints played a crucial role in shaping the design choices and the overall development process of the color mixing device. By addressing these constraints effectively, we were able to devise a functional and affordable solution that met the desired objectives.

2.2 Earlier coursework

The successful completion of this project relied upon the knowledge and skills acquired through various coursework undertaken by the team. Key coursework that directly contributed to the project includes:

1. **Electronics and Circuit Design:** This course provided a solid understanding of electronic components, circuit analysis, and the principles of analog and digital electronics. The knowledge gained in this course was crucial for designing and implementing the circuitry of the color mixing device, including the motor control circuits, sensor interfaces, and power supply.
2. **Micro-Processor:** Through this course, we acquired knowledge in programming microcontrollers and interfacing them with peripheral devices. It covered topics such as input/output (I/O) operations, sensor integration, and communication protocols. The skills acquired in this course were vital for programming and integrating the Arduino Mega microcontroller, LCD, Keypad, and other modules into the color mixing device.
3. **Micro Controllers:** : The Microcontrollers course focused on concepts such as system modeling and controller design. It provided us with a solid foundation in understanding and implementing control algorithms for motor movements and syringe operations in the color mixing device. The knowledge gained from this course helped us design and implement precise and efficient control mechanisms for achieving accurate color mixing and dispensing.

By leveraging the knowledge and skills acquired from these earlier coursework, we were able to apply theoretical concepts to practical engineering challenges encountered during the development of the color mixing device.

Chapter 3: Literature Review

In this chapter, we provide a review of relevant literature and works that have contributed to the understanding and development of automated color mixing devices. This review demonstrates our familiarity with the topic and provides a background understanding of the subject matter.

Color mixing devices have been widely studied and developed for various applications, ranging from simple devices like mixing lights to more complex machines used for paint mixing in the automotive and home paint industries.

We found some implementation of our project and we proceed to find ways how we can improve them. reducing the time needed to produce a color, increasing accuracy, add mixing feature that we noticed its missing on the previous implementation, increase the number of syringes and motors, and alot more that we'll discuss through the report.

During our research, we came across the MESOMIX Automated Paint Mixing Machine on Instructables [1]. This project presented an automated paint mixing machine that served as an inspiration for our own project especially at with our initial design to use pumps before switch to motors and syringes. We also came across a video of a graduation project from our university in 2021 [2]. The video showcased a color mixer that featured a single syringe but lacked a mixing feature, requiring the sequential filling and emptying of each color. This inspired us to make significant improvements to the performance and design of our automated color mixing device.

To further enhance our understanding of motor control using Arduino, we consulted a tutorial titled "Arduino DC Motor Control Tutorial - L298N | PWM | H-Bridge" on the HowToMechatronics website [3]. This tutorial provided a comprehensive guide on controlling DC motors with Arduino using the L298N motor driver module. It covered topics such as motor connections, PWM control, and H-bridge configuration. The knowledge gained from this tutorial was instrumental in implementing the motor control functionality in our color mixing device.

Additionally, we referred to a research paper titled "Automated Color Mixing Machine using Arduino" published in the International Journal of Engineering Research and Technology [4]. This paper presented a detailed study on the design and implementation of an automated color mixing machine using Arduino microcontroller. It discussed the hardware setup, control algorithms, and user interface for the device. The insights provided in this research paper have informed our own approach to designing and implementing the color mixing device.

To ensure accurate color conversion, we relied on a resource titled "RGB to CMYK Conversion" on the website GoodConverters [5]. This resource provided an explanation of the RGB and CMYK color models, along with the conversion formulas and algorithms required to convert RGB values to CMYK values. It assisted us in implementing the color conversion functionality in our device.

By incorporating the knowledge and insights gained from the literature review, including the MESOMIX project [1], the graduation project video [2], tutorial [3] research paper [4] and online resource [5], we have enhanced our understanding of the subject matter and applied relevant techniques and methodologies to the design and development of our automated color mixing device.

Chapter 4: Methodology

In this chapter, we discuss the design of our automated color mixing system, the components utilized to achieve its functionality, and the development process leading to the final outcome.

4.1 Overview of The System

The system we have developed is an automated color mixing device that enables users to input RGB values and obtain accurate color mixtures. The device consists of several key components and subsystems that work together to achieve the desired functionality.

1. Input Module:
 - a. Users interact with the system through an input module where they enter the RGB values of the desired color.
 - b. The input module is designed to be user-friendly and intuitive, providing a convenient interface for color selection.
 - c. There is two ways to input color data either by enter it on the keypad or through the mobile application.

2. :Color Conversion
 - a. Once the RGB values are inputted, the system employs algorithms and calculations to convert them into CMYK values.
 - b. The color conversion process ensures accurate representation and compatibility of colors across different color models.

3. : Pre-Mixing Checks
 - a. Once a command of mixing arrives to the device, it will check the amount of colors in each cup to ensure there is sufficient amount, using ultrasonic sensor.
 - b. Another check is for the existence of the output cup in its right place using IR module.

4. Syringe and Motor Control
 - a. The system utilizes motors and syringes to precisely measure and dispense the required amounts of colors (Cyan, Magenta, Yellow, and Black) and there is a sensor to make sure that there is an output cub.
 - b. Each syringe is controlled by a dedicated motor, allowing for controlled and accurate colorant dispensing.

5. : Mixing and Blending
 - a. After the colors are dispensed, a mixing mechanism is activated to thoroughly blend the colors and create the final mixture.
 - b. The mixing process ensures a well-integrated color output.

6. :Cleaning and Maintenance

After each color mixture, the system initiates a cleaning procedure to flush the syringes and proper maintenance and prevent color contamination.

4.2 Hardware Components and Implementation

In order to demonstrate the process of ArtiMixer development and its component and design:

1. :Arduino Mega

The Arduino Mega acts as the main controller, overseeing the overall operation of the device. It receives the RGB values from the user input module and performs the necessary calculations and algorithms to convert them into CMYK values. This process ensures accurate color representation and compatibility with the color mixing system. Once the CMYK values are obtained, the Arduino Mega sends them to the Arduino Uno for further processing.

Moreover, the Arduino Mega also handles the rotational movement of the upper part of the device, where the syringes and the mixer are located. It controls the rotation mechanism, enabling proper positioning and alignment of the syringes during the dispensing process. Additionally, it manages the up and down movement of the color cups and water cups, facilitating the filling and emptying processes.

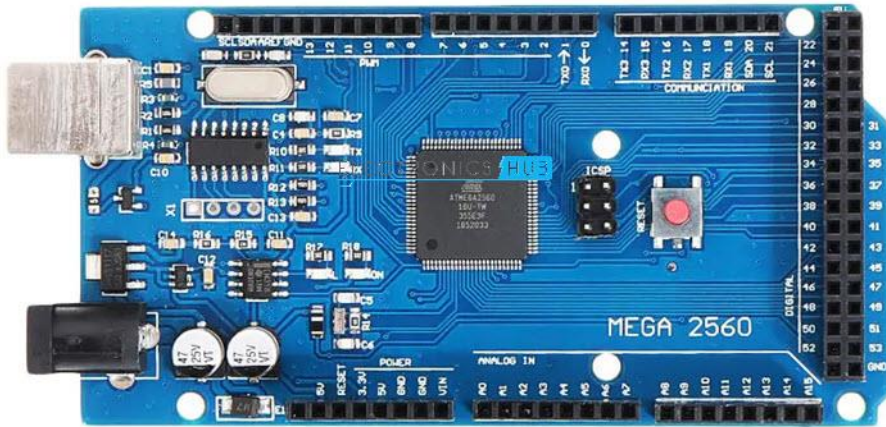

Figure 1 Arduino Mega

2. Arduino UNO

The Arduino Uno is dedicated to motor control and operates the syringe motors responsible for dispensing the desired amounts of colorants. It receives the CMYK values from the Arduino Mega and translates them into appropriate motor movements. Each syringe is controlled independently, allowing precise measurement and dispensing of the required colorant quantities. Additionally, the Arduino Uno controls the operation of the mixer, ensuring thorough blending of the colors to achieve a well-mixed final color output.



Figure 2 Arduino Uno

3. DC gear motor and L298N Driver:

A DC gear motor is a type of motor that combines a direct current (DC) motor with a gearbox. The gearbox is designed to reduce the motor's speed and increase its torque output. This allows the motor to provide higher torque and better control for applications requiring precise movement.

The L298N(H-bridge) is a popular motor driver module commonly used to control DC motors. It is specifically designed to control the direction and speed of DC motors using pulse-width modulation (PWM) signals .

To control the movement of the syringes, water cups, color cups, and the mixer, we have employed DC gear motors in conjunction with H-bridge motor driver modules. The H-bridge configuration allows for bi-directional control of the motors, enabling precise positioning and movement.

Each syringe is equipped with a DC gear motor connected to an H-bridge motor driver module. The Arduino Uno, which serves as the controller for motor operations, sends signals to the motor driver modules to control the rotation and speed of the motors. By varying the voltage and polarity applied to the motors through the H-bridge, we can control the forward and backward movement of the syringes, accurately dispensing the desired amounts of colorants.

Similarly, the up and down movement of the water cups, color cups, and the mixer is facilitated by DC gear motors controlled by H-bridge motor driver modules. The Arduino Mega, acting as the main controller, sends signals to the respective motor driver modules to control the rotation and speed of these motors. This allows for smooth and precise vertical movement of the components, ensuring proper positioning for filling, emptying, and mixing operations.

The combination of DC gear motors and H-bridge motor driver modules offers a reliable and versatile solution for controlling the various movements within the color mixing device. The precise motor control provided by the H-bridge allows for accurate positioning and smooth operation, enhancing the overall functionality and performance of the system.

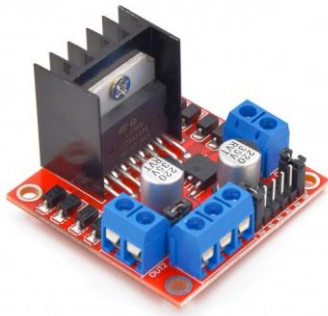

Figure 3 L298N Driver



Figure 4 Dc gear motor

4. Syringes

The syringes play a critical role in our automated mixing device, enabling precise measurement and dispensing of the calculated CMYK colors. We used a 10ml syringes, which offer an ideal capacity for accurately filling and emptying the required amount of each color component. By utilizing the syringes, we ensure that the device delivers the precise quantities needed to achieve the desired color shade, enhancing the accuracy and reliability of our color mixing process.



Figure 5 10ml syringe

5. :LCD

The LCD (Liquid Crystal Display) plays a crucial role in our system by providing visual feedback to the user. It serves as a display interface that shows the RGB value entered by the user, allowing them to verify the accuracy of their input. Once the RGB value is converted to CMYK, the LCD displays the resulting CMYK value. This real-time display on the LCD enhances user interaction and provides immediate feedback, ensuring transparency and clarity throughout the color mixing process.

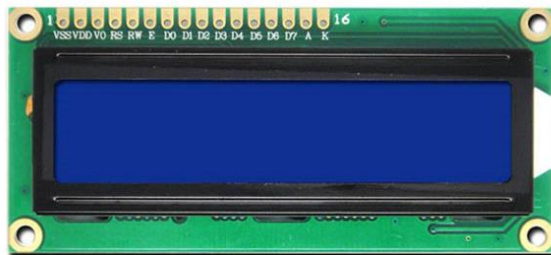

Figure 6 LCD 16*2

6. :Keypad

The keypad serves as one of the primary input methods in our system, allowing users to input the desired RGB value they wish to produce. By using the keypad, users can conveniently enter the specific RGB values they desire. The entered RGB value is then converted and processed accordingly to generate the corresponding color output. The keypad provides a user-friendly interface for interacting with the color mixing device, enabling precise and customized color selection.

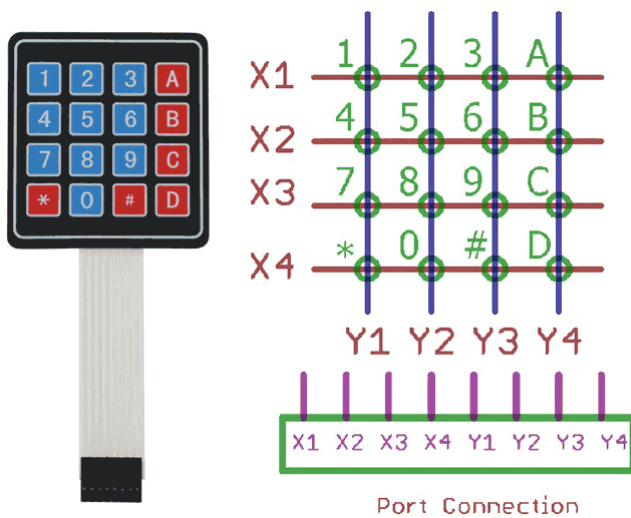

Figure 7 Keypad 4*4

7. Esp 8266 Wi-Fi Module

The ESP8266 Wi-Fi module, integrated into our development board, played a crucial role in our project. Based on the WiFi-SoC ESP8266, this module is specifically designed for rapid prototyping in the Internet of Things (IoT) domain. In our implementation, we utilized the ESP8266 module to receive data from the secondary input, which was connected to a mobile application. The received data was then transmitted through serial communication to facilitate the color conversion process and generate the desired color output. By leveraging the capabilities of the ESP8266 module, we achieved seamless integration between our color mixing device and the mobile application, enabling efficient data transfer and control.



dispensed. Furthermore, the motors facilitate the rotation required for mixing the colors effectively.

Once the color mixing process is complete, the motors rotate the upper part to position the syringes above the cleaning area. This allows for the syringes to be cleaned with water, ensuring that any remaining color is removed. After cleaning, the motors move the upper part back to its initial location, ready for the next color mixing operation.



Figure 9 DC Gear Motor 25GA370

9. Ultrasonic Sensor

Ultrasonic sensor is used to measure distance using ultrasound waves, in our device it was used before the colors are pulled from the cups to ensure that there is enough amount of color in every cup, if this check was passed the device can continue on the process of generating the requested color, the distance which is measured by this sensor is also used to decide how much to lift the color cups base to pull the required amount of colors.



Figure 10 ultrasonic sensor

10. IR Obstacle Avoidance Module

IR module contains both infrared emitter, infrared sensor, and a potentiometer to adjust the detection range, the emitter will emit radiation and if there is no obstacles to reflect this radiation the infrared sensor won't detect any infrared signals, but when an obstacle is inserted to reflect the radiations the sensor will detect the signals and though detect the presence of the object.

This module was put below the output cup to ensure the cup is inserted at its right place to be the output color cup.



Figure 11 IR Obstacle Avoidance Sensor Module

11. Mixing Arm

To ensure the generating of a homogenous output color, we add this mixing arm which was connected to motor to mix the colors after the syringes put them in the final cup.



Figure 12 Mixing Arm

4.3 Software

In our color mixing application, we provide users with a convenient and intuitive way to input colors through the use of image selection. By incorporating this functionality, users have the option to either capture a new image or choose an existing one from their gallery. Once an image is selected, users can interact with the image by using their finger to select any desired part of the picture. The chosen area is then processed to extract its color, which is subsequently converted to CMYK values. Finally, users can apply the selected color by pressing the "Apply Color" button, which sends the converted CMYK values to the ESP8266 Wi-Fi module for further processing and color production. This image-based input method adds versatility and creativity to our color mixing device, allowing users to explore a wide range of colors from various sources and apply them effortlessly.

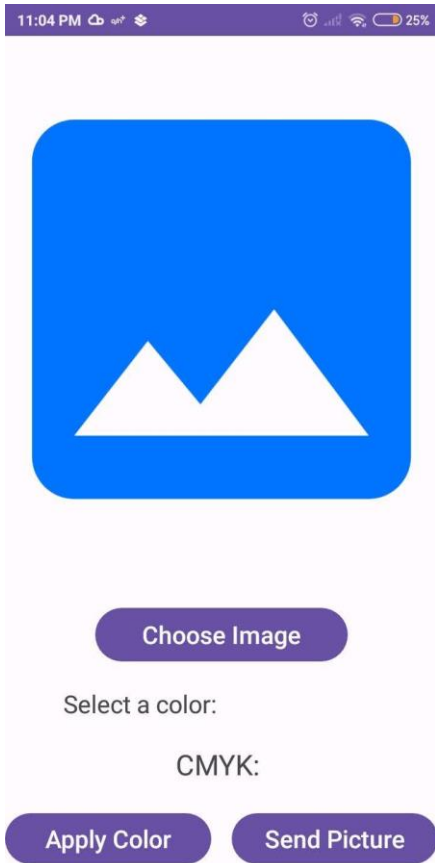

Figure 10 application, 1

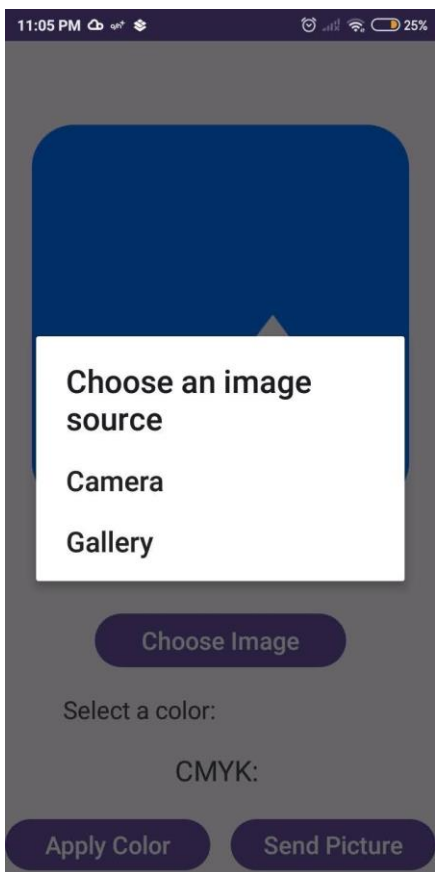

Figure 11 application, 2

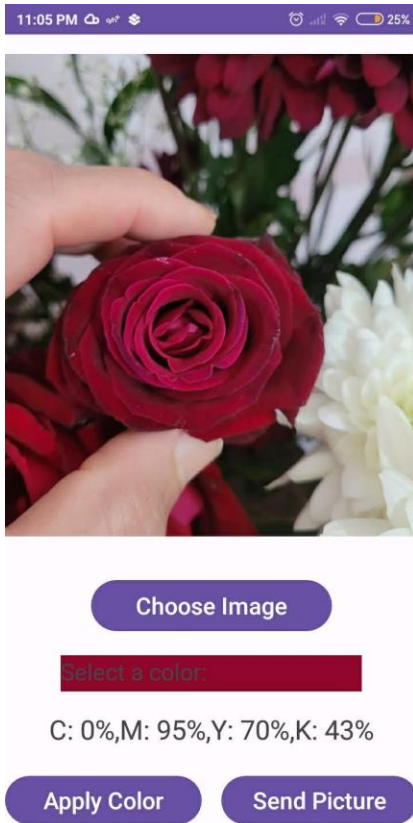

Figure 12 application, 3

Chapter 5: Results and Analysis

Throughout the course of the project, we have successfully implemented all the intended features as previously outlined. Each feature has been designed and integrated to function as expected, demonstrating the effective execution of our project goals. However, it is important to acknowledge that a few challenges were encountered along the way, resulting in some inevitable errors.

During the course of our project, we encountered a significant challenge related to the variations in speed among the DC gear motors used for filling color. Each motor had its own unique characteristics and took a different amount of time to fill a specific amount of color. To address this issue, we implemented a time calculation mechanism for each motor individually.

By carefully observing and measuring the time required for each motor to fill a predetermined volume of color, we were able to determine the specific time duration needed for each motor to achieve the desired filling level accurately. This approach allowed us to compensate for the variations in motor speed and ensure consistent and precise color measurements.

Through this adaptation, we successfully overcame the challenge posed by the discrepancies in the DC gear motors' speeds, enabling us to achieve accurate and synchronized color filling across the system.

In conclusion, our color mixing project has successfully achieved all the predetermined objectives and features. Despite encountering certain challenges and errors, our meticulous problem-solving and innovative approaches have enabled us to overcome these obstacles.

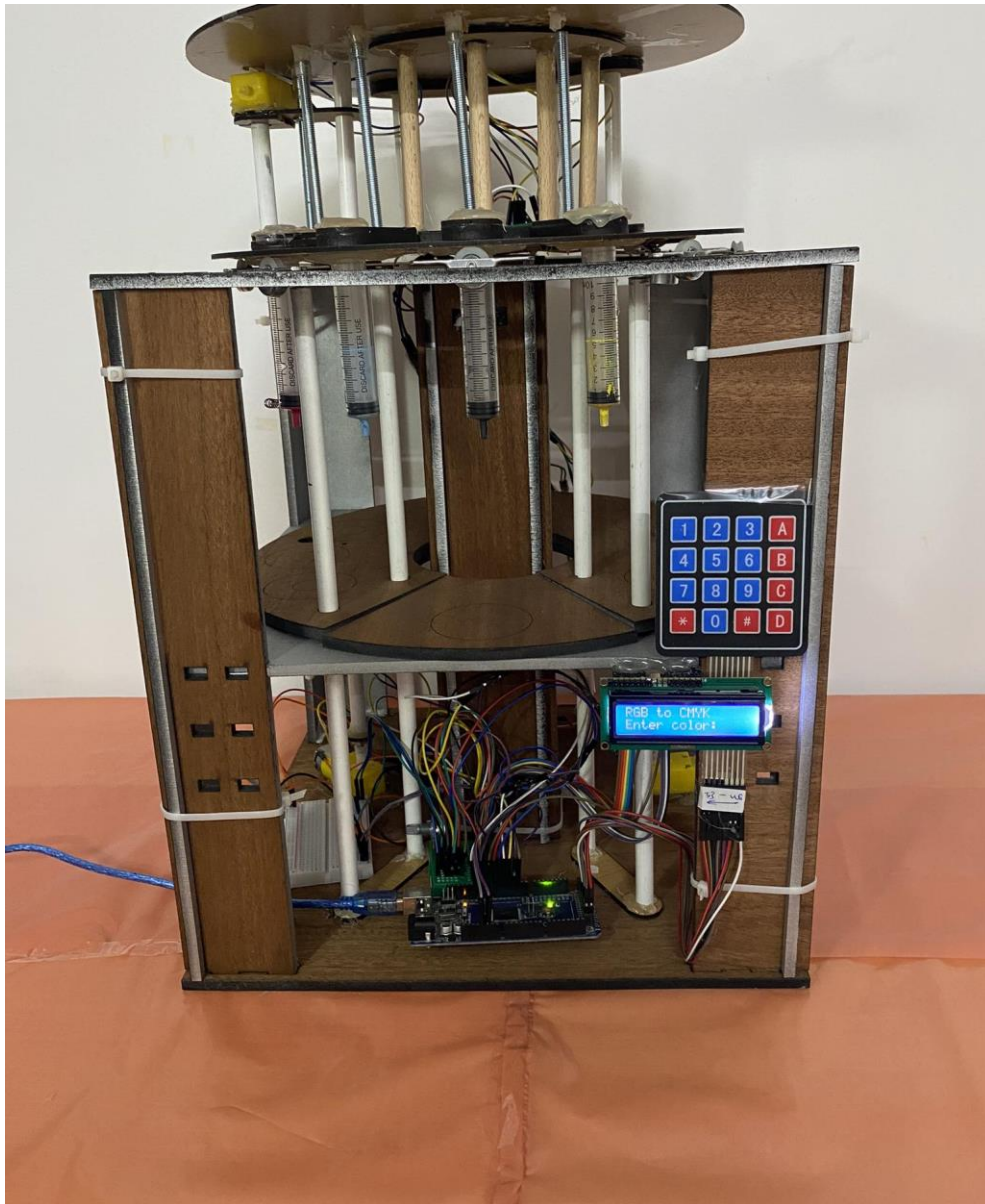

Figure 13 Device photo

Chapter 6: Conclusions and Recommendations

Based on our analysis and evaluation of the results, we draw the following conclusions:

1. Our automated color mixing device successfully achieves its intended objectives of accurately mixing colors based on user-entered RGB values and converting them to CMYK. The device demonstrates efficiency, precision, and reliability in the color mixing process.
2. The improvements and enhancements we implemented, such as reducing color production time, use a syringe for each color, increasing accuracy, and incorporating a mixing feature, have significantly enhanced the functionality and performance of the device compared to existing implementations.
3. The utilization of Arduino microcontroller and motor control techniques proved to be effective in achieving precise control over the syringe movements, allowing for accurate color dispensing and mixing.
4. The incorporation of RGB-to-CMYK conversion algorithms has enabled seamless color transformation, ensuring accurate color representation and compatibility with various printing and color reproduction systems.

Based on our findings and the identified areas for improvement, we recommend the following cost-effective and feasible ways to further enhance the performance of the color mixing device:

1. Explore the integration of advanced sensors and feedback mechanisms to enhance color measurement accuracy and ensure precise color reproduction.
2. Conduct further research to optimize the speed and efficiency of the color mixing process, allowing for faster production and improved productivity.

In conclusion, our project has successfully developed an automated color mixing device that achieves accurate color mixing and conversion. This project serves as a stepping stone for future research and development in automated color mixing devices, and we encourage further exploration in the following areas:

1. Investigation of alternative color models and conversion algorithms to cater to different color spaces and industry requirements.
2. Exploration of real-time color monitoring and adjustment mechanisms to ensure continuous color consistency during extended production runs.

3. Integration of machine learning techniques to optimize color mixing algorithms and enhance the device's adaptability to varying color requirements.

In conclusion, our project has not only achieved its objectives but also opened up new avenues for future research and innovation in the field of automated color mixing devices.

References:

MESOMIX Automated Paint Mixing Machine. Instructables. Available online: [1]
<https://www.instructables.com/MESOMIX-Automated-Paint-Mixing-Machine>

Graduation Project Video (2021). [P-Mix || Hardware Graduation Project || 2021]. [2]
Retrieved from [https://www.youtube.com/watch?v=Dm_vltHpvcv]

Tutorial: "Arduino DC Motor Control Tutorial - L298N | PWM | H-Bridge." [3]
HowToMechatronics. Available online:
<https://howtomechatronics.com/tutorials/arduino/arduino-dc-motor-control-tutorial-/l298n-pwm-h-bridge>

Research Paper: "Automated Color Mixing Machine using Arduino." International [4]
Journal of Engineering Research and Technology. Available online:
<https://www.ijert.org/research/automated-color-mixing-machine-using-arduino-IJERTCONV6IS04081.pdf>

Online Resource: "RGB to CMYK Conversion." GoodConverters. Available [5]
/online: <https://www.goodconverters.com/rgb-to-cmyk>