

An-Najah National University

Faculty of Engineering and

Information Technology

Technology Center

By

Alia Qasim Donbok

Supervisor

Dr.

Sameh Mona

This Thesis is Submitted in Partial Fulfillment of the Requirements for the Degree of Bachelors of Engineering Architectural, Faculty of Engineering and Information Technology, An-Najah National University, Nablus, Palestine.

2022

الإقرار

أنا الموقع أدناه، مقدم الرسالة التي تحمل العنوان:
مركز تكنولوجيا
أقر بأن ما شملته هذه الرسالة إنما هو نتاج جهدي الخاص، باستثناء ما تمت الإشارة إليه حيثما
ورد، وأن هذه الرسالة ككل، أو أي جزء منها لم يقدم من قبل لنيل أيّ درجة أو لقب علمي لدى
أيّ مؤسسة تعليمية أو بحثية أخرى.

Declaration

The work provided in this thesis, unless otherwise referenced, is the researcher's own work, and has not been submitted elsewhere for any other degree or qualification.

Student's Name: Alia Donbok

اسم الطالب: علياء الدنبك

Signature:

التوقيع:

Date: 5th. Jan. 2023

<u>Abstract</u>	1
<u>Chapter One: Introduction</u>	2
1.1. History of technology.....	3
1.1.1. General information about technology.....	3
1.1.2. History of technological companies.....	3
1.1.3. History of technological companies in Palestine.....	7
1.2. The importance of the headquarter	8
1.3. The need of the headquarter	10
1.4. The main functions	11
1.4.1. Software Department.....	11
1.4.2. Hardware Department.....	12
1.4.3. Training center.....	12
1.4.4. Shared spaces.....	13
1.4.5. Gallery.....	13
<u>Chapter Two: Case Study</u>	15
2.1. Airbnb Headquarter.	16
2.1.1. Concept	16
2.1.2. Site location.	17
2.1.3. Drawings.....	19
2.2. Apple Park Headquarter.	21
2.2.1. Concept.....	21
2.2.2. Designer Vision.	22
2.2.3. Site location	24
2.2.4. Plans	26
2.2.5. Project Structure and Construction.....	31
2.2.6. Project's importance for the city.....	32
<u>Chapter Three: Project Program</u>	33
3.1. Functions.....	34
3.2. Departments and their Functional Requirements.....	34
3.2.1. Administration.....	34
3.2.2. Hardware department.....	35
3.2.3. Software department	37
3.2.4. Training center.....	41
3.2.5. Cafeteria.....	42
3.2.6. Shared spaces.....	44
3.2.7. Services	47
3.3. Operational Requirements	48
3.3.1. Security system.....	49
3.3.2. Energy system.....	50
3.3.3. Circulation system.....	51
3.3.4. Emergency system.....	53
3.3.5. Insulation system	57
3.3.6. Electricity distribution system.....	58
3.3.7. Lightening system.....	58
3.3.8. Ventilation system and Mixed-mode system	58
3.3.9. Strategies for building design and HVAC systems.....	58
3.3.10. Cleaning system	58
3.4. Project Program	59

<u>Chapter Four: Site Analysis</u>	66
4.1. Location	67
4.1.1. Regional location.....	68
4.1.2. City Selection.....	69
4.1.3. Site Location.....	72
4.2. Site Characteristics	73
<u>Chapter Five: Design</u>	79
5.1. 2D Drawings..	80
5.1.1. Site Plan.....	80
5.1.2. Basement Floor.....	80
5.1.3. Ground Floor.....	81
5.1.4. First Floor.....	82
5.1.5. Second Floor.....	82
5.1.6. Section.....	83
5.1.7. North Elevation.....	84
5.1.8. South Elevation.....	84
5.1.9. East Elevation.....	85
5.1.10. West Elevation.....	85
5.2. Exterior Shots	86
5.3. Interior Shots	89
<u>References</u>	91

List of Figures

NO.	Figure	Page
1.1	IBM Headquarters in New York year:1921	4
1.2	IBM Headquarters in Buenos Aires, 1979-1983	5
1.3	IBM headquarter in Amsterdam, 2023	6
1.4	Digital technologies for covid 19	9
1.5	The Biggest Companies in the World in 2021	9
1.6	Global distribution of digital companies and market capitalization	
1.7	Relaxation and breakout spaces most important for productivity	
2.1	Site Location	17
2.2	Site Accessibility	18
2.3	Ground floor plan	19
2.4	First floor plan	20
2.5	Interior spaces	20
2.6	Building Section	21
2.7	Site Trees before and after construction	22
2.8	Comparing site before and after construction	24
2.9	Apple's old campus site	24
2.10	Apple's new campus site	25
2.11	Site details	26

2.12	Site circulation	27
2.13	Ground Floor	28
2.14	Headquarters' Circulation	29
2.15	Campus Isometric	30
2.16	Horizontal shades	30
2.17	Ventilation	32
3.1	Reception counter dimensions	36
3.2	Seats dimensions	37
3.3	Smart desk	38
3.4	Software department plan	39
3.5	Desk dimensions	40
3.6	Meeting room dimension	40
3.7	Servers' floor	41
3.8	Conference hall dimension	42
3.9	The training center sample	43
3.10	Workstation	44
3.11	Office room types	46
3.12	kitchenette types	47
3.13	Dimensions of toilet units	48
3.14	Access control system	49
3.15	Proximity access control	49
3.16	Elevators dimensions	51
3.17	Stair	52
3.18	Stair dimension	52
3.19	Emergency escape route	53
3.20	Insulating glass	55
3.21	Insulating glass types	55
3.22	Natural light	56
3.23	Personal suspension systems	58
4.1	Regional location	67
4.2	Company Distrebution	67
4.3	Site location	68

4.4	Defined site	69
4.5	Site Surroundings	69
4.6	Site Population	70
4.7	Solid and void	70
4.8	Surrounding type buildings	71
4.9	Site's surrounding roadways	71
4.10	Site accessibility	72
4.11	City exit and the site	72
4.12	Site contour	73
4.13	City temperature	73
4.14	City humidity	74
4.15	City precipitation rate	74
4.16	City wind speed	75
4.17	Summer sun direction	75
4.18	Winter sun direction	76
4.19	Stream Line	77
4.20	Parcels	77
4.21	Classification	78
4.22	Site topography	78

List of Tables

No.	Table name	Page
1.1	Key segments of the global IT Market	10
2.1	Comparing percentage	23
3.1	Space requirements for workstation	45

Technology Center

**By
Alia Donbok**

Abstract

In this research, I intend to design a smart technological headquarters based on high international architectural standards, including a hardware sector, gallery, software sector, and training center that serves employees, visitors, instructors, and students.

In these days and age, every single field, no matter how large or little, requires the IT sector, considering the economy sector to be the most important in our world, the IT sector plays a significant role in it as well and helps to improve it, because production and the economy in current times and in the future rely around technology.

This company, which will be a worldwide competitive firm, will achieve the major aims for this building, which revolve on Palestine's economy, educational level, technological level, and architectural level. The presence of a corporation with advantages and developments would position Palestine as a worldwide competitor for technological companies, as well as many new job opportunities and high-efficiency graduates, improving Palestine's income and economic standing while lowering unemployment.

So, after studying several case studies and standards, the most effective facilities for achieving these goals are the shared spaces, creative ones, nature, vegetation, and green areas, as integration between nature and smart building with the concept of sustainability throughout using lights spaces and materials to reflect a suitable atmosphere for the employees, in addition to raising the ratio of the void spaces over the solid, which will lead to a growth in the level of architecture in Palestine with the intent of snooping into the future.

Chapter One

Introduction

1.1. Introduction

In a world where technology and virtual reality are prevalent, all juniors and human being are heading to be interested in this field, as well technology involved in all the specialties,

And it's controlling the world with all its aspects, so we cannot neglect its importance,

In this era every single field has a technology sector in it, and whenever technology exist it makes things easier and more advanced.

1.2. History of technology

Million years ago started the definition of technology by inovate new tools to evolve results and shorten procedure time.

Technology as a etymology, 'The word technology comes from two Greek words, transliterated techne and logos. Techne means art, skill, craft, or the way, manner, or means by which a thing is gained. Logos means word, the utterance by which inward thought is expressed, a saying, or an expression. So, literally, technology means words or discourse about the way things are gained.' (Ken Funk)

The definition of technology has changed recently. The definition above would include art or politics as means of earning, but even though those activities are now heavily influenced by technology, most of us would not regard them as examples or subsets of technology.

In this sense, the term has come to mean something more specific. In another sense, this definition is too limited because, when most of us talk about technology today, we're not just talking about discussing ways to make money.

Technology has multiple definitions, we can simplify it to five senses, First, technological process which means that technology is a methodical act of creating means to order and transform matter, energy, and information to realize certain valued ends.

Second, technological objects, which can be considered as that technology is the set of means (tools, devices, systems, methods, and procedures) produced by the technological process is known as technology, Technological objects range from using stone as a chopping tool to transportation systems.

Third, technological knowledge, Here in this definition we definite technology as the knowledge that enables technological processes, It includes of the facts and procedures needed to organize and control matter, energy, and information as well as how to discover new means for such transformations.

And the fourth definition becoming more close to our known expression technology and it's a subset of related technological objects and knowledge. Technologies include, for instance, computer and medical technology.

Finally we arrived to the point to explain the last definition of technology 'the technological system' which is the one we are using in these ages, it says that technology is a system includes technological process, technological objects, technological knowledge, developers of technological objects, users of technological objects, and the worldview, so its comprehensive.

1.2.1. History of Technological Companies

IBM, or International Business Machines, was founded in 1911. They were formerly known as the Computing-Tabulating-Recording Company. The C-T-R Company was not created by founder Charles Ranlett Flint out of nothing. It was founded instead via the merging of three enterprises that had operated since the late 1800s: the Computing Scale Company, the Tabulating Machine Company, and the Time Recording Company. The newly merged corporation had around 1,300 workers and was located in New York City. (Today, IBM employs around 350,000 workers.)

During its early years, the C-T-R Company concentrated on items such as accounting and calculating machines, business time recorders, and mechanical punch card systems. Rather than being the invention-driven corporation it subsequently became, it focused on typical office items.

In 1924, Thomas Watson took over as CEO and renamed the corporation International Business Machines, or IBM. In his early years, Watson based IBM's success on business and marketing methods, designing goods tailored to individual customers' requirements, and extensively investing in the company's sales staff.

IBM and the Computer:

The Vacuum Tube Multiplier, the first entirely electronic computing device, was created by the company in 1943. This resulted in the creation of the 1944 Automatic Sequence Controlled Calculator, or "Mark I," by IBM and Harvard. The first thing that we would recognize as a modern computer was this gadget. It was 50 feet long and 8 feet tall, and it automatically carried out electromechanical calculations. The Mark I was used by the U.S. Navy to determine the gun trajectories on its ships.

IBM developed many of the key technologies that allowed computers to become commonplace in business during the 1950s and 1960s. Up until the development of the microchip, it produced the working vacuum tube computer, which served as the foundation for all computers. IBM also developed the hard drive, which enabled it to build the first computer with spinning platters for data storage and a magnetic arm for data retrieval. It also produced FORTRAN, the forerunner of the majority of contemporary computer coding languages.

IBM Today:

The Personal Computer 5150, also known as the "PC," may have signaled the start of IBM's modern era in 1981. One of the first computers designed for home use as opposed to use by the government or business.

IBM's Timeline:

1911 - IBM is founded as the Computing-Tabulating-Recording Company. It was formed by the merger of three companies: Computing Scale Company, Tabulating Machine Company, and Time Recording Company.

1924-Thomas Watson buys the company and renames it International Business Machines, or IBM.

1935-IBM was chosen by the Social Security Administration to build data management machines for the new Social Security program.

1952-IBM begins to expand its computing business under the leadership of Thomas Watson Jr. It sells mainframe computers based on its vacuum tube design and quickly becomes the market leader.

1957-IBM creates FORTRAN, a computer coding language that would serve as the foundation for most other modern coding languages.

1991-IBM decides to focus on its business services division in the face of a declining mainframe market and intense competition in the personal computer market.

1996/1997-Deep Blue, IBM's artificial intelligence program, competes against world chess champion Garry Kasparov. The first match is won by Kasparov, but the second is lost by a computer—the first time a computer has ever defeated a world champion in a traditional match.

2005-IBM sells its personal computing division to Lenovo, refocusing on the business services model, which still accounts for the majority of the company's profits today.

IBM headquarters now and then:



(Figure 1.1: IBM Headquarters in New York year: 1921)

This is the IBM headquarters in New York in 1921, when it was only a floor in one of the city's buildings.

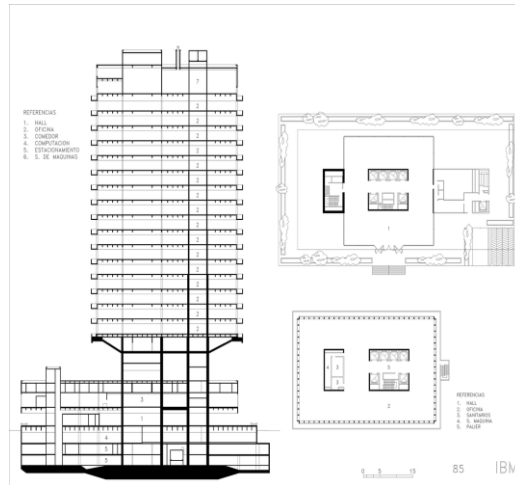

(Figure 1.2: IBM Headquarters in Buenos Aires, Argentina year :1979-1983)

This is the IBM headquarters, which was built in the late 1970s in Buenos Aires. We can see how it began to have its own building, but it only has floors for working offices and meeting rooms.



(Figure 1.3: IBM Headquarters in Amsterdam, year: 2023)

This is the most recent design for the new IBM headquarters in Amsterdam, which will build in 2023. In addition to fitness areas, restaurants, and lecture halls, the 35,000 square meter building will house startups.

1.2.2. History of Technological Companies in Palestine

There isn't much information regarding the first Technology Company in Palestine, but the oldest ones I could find were founded in the late 1980s, and they are 'Halli, Samcoo, and Turbo for computer and software.'

Because this sector was not popular among Palestinians at the time, the number of corporations and enterprises was small, and there isn't much to say about their activity.

So, when it comes to Samcoo, it began in the late 1980s as a small shop for calculator maintenance, then in 1981 they entered the first automatic telephone and phones in Nablus, by 1982 the first video machine had entered the city, and in 1984 the first computer was accessed to the city and sold to an insurance company. 1992 SAMCO's broad distribution. When personal computers first appeared, And they began to enter other branches of fire alarms and printers, opening a branch

in Jerusalem in Dahiyat al-Bareed, another in Ramallah in al-Irsal, and another in Gaza, and it had a wide spread and great success in Palestine, Specially in computer networks and telephones. (AbdelHadi, 2022).

1.3. The importance of the project:

Nowadays, in this day and age, every single field, no matter how large or little, requires the IT sector.

So, if we consider the economy sector to be the most important in our world, the IT sector plays a significant role in it as well and helps to improve it, because production and the economy in current times and in the future rely around technology.

Another important example is the health sector, where the IT business has a large impact.

New and emerging technologies have transformed healthcare in recent years. So large and small hospitals and physician offices have embraced new technology in response to a changing regulatory environment and to improve overall patient care quality.

And as we know today's medical facilities are high-tech operations that place cutting-edge technologies in the hands of skilled specialists.

The same goes to the transportation, business, schools and universities.

And we understood the importance of this sector during the most recent pandemic, when the entire world was quarantined and everyone had to work, study, and live virtually from home. And this was the role for the IT sector. So, if we imagine existence without it, the world would have come to a halt for two years in a row.

Also, programmers can work from home 'virtually,' but according to several surveys, programmers and employees' productivity is depending on the facilities that are provided for them, The word 'facilities' refers to taking into account the place, activities, and departments, so taking care of the smallest elements to ensure that employees are comfortable in their working environment can increase productivity and creativity.

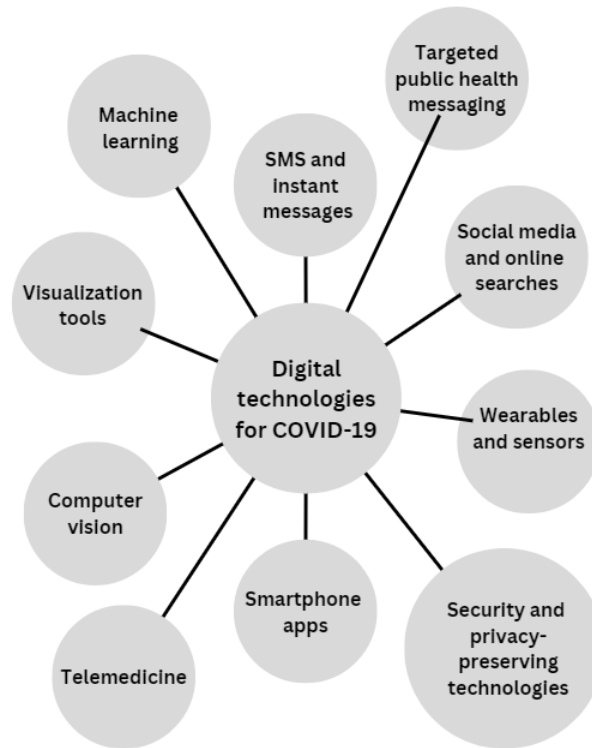

Figure1.4 (digital technologies for covid 19) (Nature Medicine, 2020)

This diagram depicts the kind of technology required throughout the covid-19 pandemic to allow life to continue as it had before covid-19, so we can discover from this figure how importance is the technology, and how it is including all aspects of life and keeping it continuing.

It is the interconnected digital technologies used in the public-health response to COVID-19, many approaches employ a mix of digital technology and may rely on telecommunications infrastructure and internet access. For clarity, machine learning is depicted as a distinct branch, despite the fact that it supports many of the other technologies. A large portion of the data collected by these technologies is sent into data dashboards. SMS stands for short message service.

Table 1.1 (The Biggest Companies in the World in 2021) (Jenna Ross, 2021)

Rank	Company name	Location	Sector	Market Capitalization
1	APPLE INC	 United States	Technology	\$2.1T
2	SAUDI ARAMCO	 Saudi Arabia	Energy	\$1.9T
3	MICROSOFT CORP	 United States	Technology	\$1.8T
4	AMAZON.COM INC	 United States	Consumer Discretionary	\$1.6T
5	ALPHABET INC	 United States	Technology	\$1.4T
6	FACEBOOK INC	 United States	Technology	\$839B
7	TENCENT	 China	Technology	\$753B
8	TESLA INC	 United States	Consumer Discretionary	\$641B
9	ALIBABA GRP	 China	Consumer Discretionary	\$615B
10	BERKSHIRE HATHAWAY	 United States	Financials	\$588B

This table ranks the world's largest corporations in order of the market capitalization, from largest to smallest. And it provides a clear picture of how the IT industry controls the global economy.

1.4. The need for the project:

By looking at the world's most powerful countries in terms of economics and information, we notice that the United States is the most powerful economically since it controls the software industry and technological breakthroughs.

Any country that has developed in software and technology, appears and is well-known around the world, and it significantly helps the economy. That is why the presence of a large technology company that includes hardware and software makes Palestine an independent and globally recognized country, providing many job opportunities for graduates, which helps and develops the country's economy, as well as the presence of a training center that supports students and programmers in terms of education, and in these ways to improve the economy.

The presence of a company that has advantages and developments will make Palestine a global competitor for the Technological Companies and this technological development attracts large technological companies and the possibility of opening branches in Palestine, such as Apple headquarter when they recognize the development of Rawabi city, so they open a branch in Palestine and employ a lot of employees.

And it provides many new job opportunities, and the salaries in these companies are comparable to worldwide salaries, which increasing Palestine's revenue and economic status while decreasing unemployment.



Figure 1.5 (Global distribution of digital companies and market capitalization)(Andrea Murphy,2018)

This graph displays the market capitalization (US \$billion) and distribution of the top 100 digital companies worldwide. It is clear from this graph that the Middle East lacks significant international technology enterprises.

1.5. The main functions:

1.5.1. Software Department:

A set of instructions, data, or programs used to run computers and carry out specified activities is referred to as software. It is the inverse of hardware, which describes a computer's physical components. Because software is a broad phrase that refers to apps, scripts, and programs that run on a device, the software department at our firm is the department in charge of designing, programming, and developing the software components of the company's goods.

Main sections of software department:

- Administration offices
- Developers offices
- Ui/Ux designers offices
- Activities room
- Shared working space

- Cafeteria
- Services
- Sitting areas

1.5.2. Hardware Department

Hardware is the physical components that a computer system requires to function. It encompasses everything with a circuit board that operates within a PC or laptop for example.

Main sections of hardware department

- Administration offices
- Hardware engineer offices
- Hardware parts designers offices
- Labs
- Shared working space
- Cafeteria
- Services
- Sittings areas

1.5.3. Training center

Since technology is always developing, trained workers are required to build, maintain, and upgrade systems. Typically, starting an information technology training firm entails analyzing your community's requirements and developing a business plan that specifies how your organization will deliver in-demand courses and services. A typical IT training company teaches topics such as operating system usage, office application recommendations, programming skills, network security, and database administration.

In terms of education, we may consider the training center to be an educational firm for undergraduate university students who are taking courses and upgrading their abilities.

1.5.4. Shared spaces

Considering shared spaces as a main function of a technology company, because, as previously mentioned, IT employees spend their entire day in front of screens, with no human interaction, no social life, and no healthy life, the presence of shared spaces motivates workers, breaks up the routine, and improves their social life while also increasing productivity.

1.5.5. Gallery

As a large technology firm with a large hardware sector, it creates items and should have a gallery to exhibit those products and, of course, to sell them to customers.

Key Segments of the Global IT Market

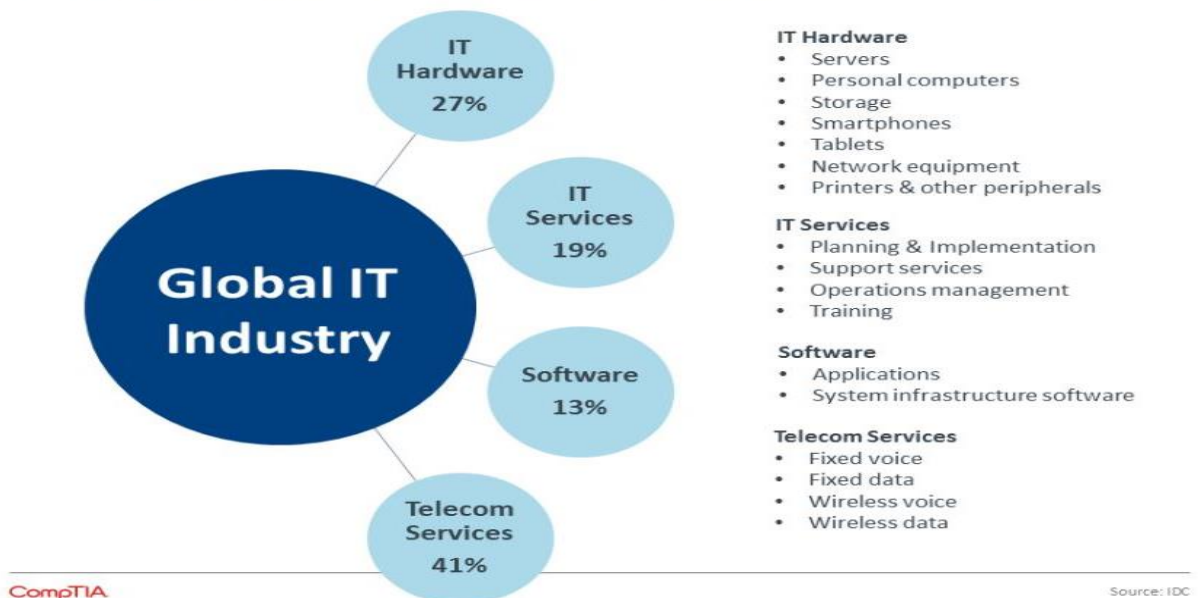

Figure 1.6 (Key segments of the global IT Market)(IDC)

This graph depicts the percentages of the sectors in the worldwide IT market, and my project focuses on developing a firm that includes IT hardware, IT services, and software, which accounts for 59% of what the global IT industry has to offer.

What do you think would improve your productivity levels at work in terms of office design?

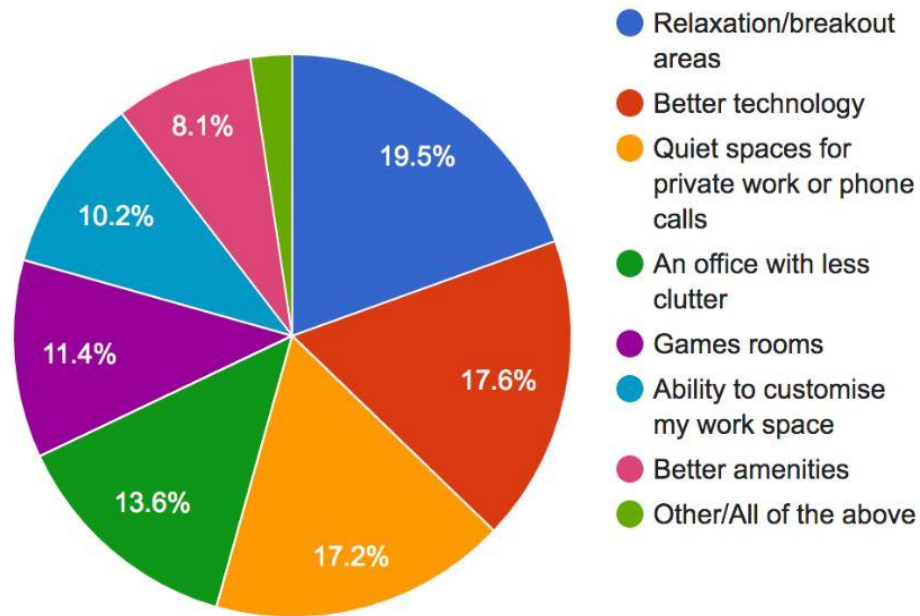

Figure 1.7 (Relaxation and breakout spaces most important for productivity) (Dale)

This figure shows how the productivity will be increased when the workers are surrounded by a healthy environment.

Chapter Two
Case Study

2. Case studies:

After researching various case studies, I figured out that the two cases I can take advantages from are: Apple Headquarter, and Airbnb Corporation.

Apple headquarters in Cupertino, California, is a case study from which I can discover how they improve the design to increase the employees' productivity in several ways such as: integrating the outside nature into the inside, increasing the number of trees even after construction, isolating the software sector and software's employees for the high privacy required but also gathering them with the people, so they interact and socialize with the hardware employees and visitors at the gallery by constructing only one restaurant and various shared spaces,

But as it is too big comparing to the area of my project I analyzed Airbnb Corporation to make sure about analyzing the spaces and the relations between them, specially the software sector.

2.1 Airbnb Headquarter

A corporation that maintains one of the Internet's largest and most significant websites, as it has a complicated software headquarters, many staff, and is present in several locations across the world. This case is now being investigated in Seattle, United states.

Airbnb, one of the world's largest marketplaces for unique, authentic places to stay and things to do, has grown to over 4 million Hosts who have welcomed over 1 billion guest arrivals to over 100,000 cities and towns in almost every country and region around the world, with 85% of Hosts located outside of the US. Once there were millions of homes on Airbnb, the firm discovered that Hosts could contribute not only their houses but also their hobbies and abilities. The US contributes for around half of the company's overall revenue.

2.1.1. Concept

To achieve its full potential, any technology requires the correct environment. In order for a firm to get the greatest benefits from technology, it must embrace and foster a strong digital culture - and a well-designed workplace is one such contributor.

This Company in Seattle, which was created with the modern workplace, ensuring that workers are in an atmosphere that genuinely brings out the best in them.

The emphasis of the office is on various personnel with varying demands and abilities. Each employee may choose how and where he or she wants to work at any time and on any day, from private quiet locations for serious concentrate to more open collaborative workstations that stimulate debate and creativity.

The office offers a work environment with state-of-the-art equipment throughout. There is various conference meeting rooms, cafes, and their workstations.

The conference rooms are of the highest technological level, all expressly built for a new era of networked collaboration, collaborative processes, and effective meetings.

The firm's is intended for teamwork, which the corporation likes to term "the new way of working".

The human factor is everything, Today's technology allows us to choose when and where we work. Those who can design their job flexibly and freely might attain not just a better work-life balance, but also greater motivation and a higher degree of.

Flexible kinds of employment improve and stimulate employee innovation and productivity. According to a research conducted by the Kiel Institute for the World Economy, firms that use flexibility have up to 14% more new or upgraded items on the market than those that use traditional working hour laws.

This shift in working culture might provide new issues for businesses in terms of office structure and headquarters design.

2.1.2. Site location

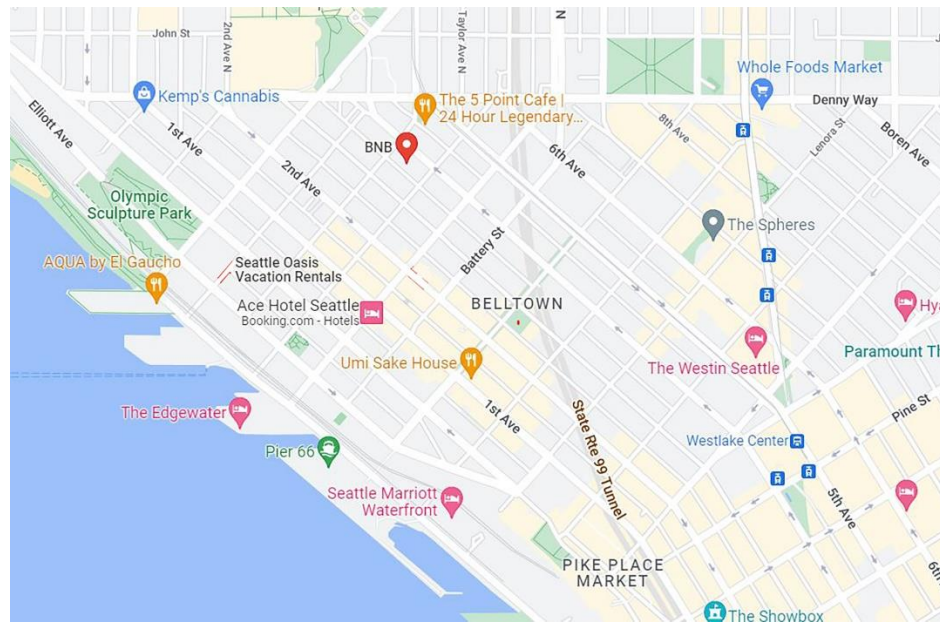

Figure2.1 (Site location) (Google maps)

This figure shows the location This Corporation located in Seattle, United states. In the north of the city center.

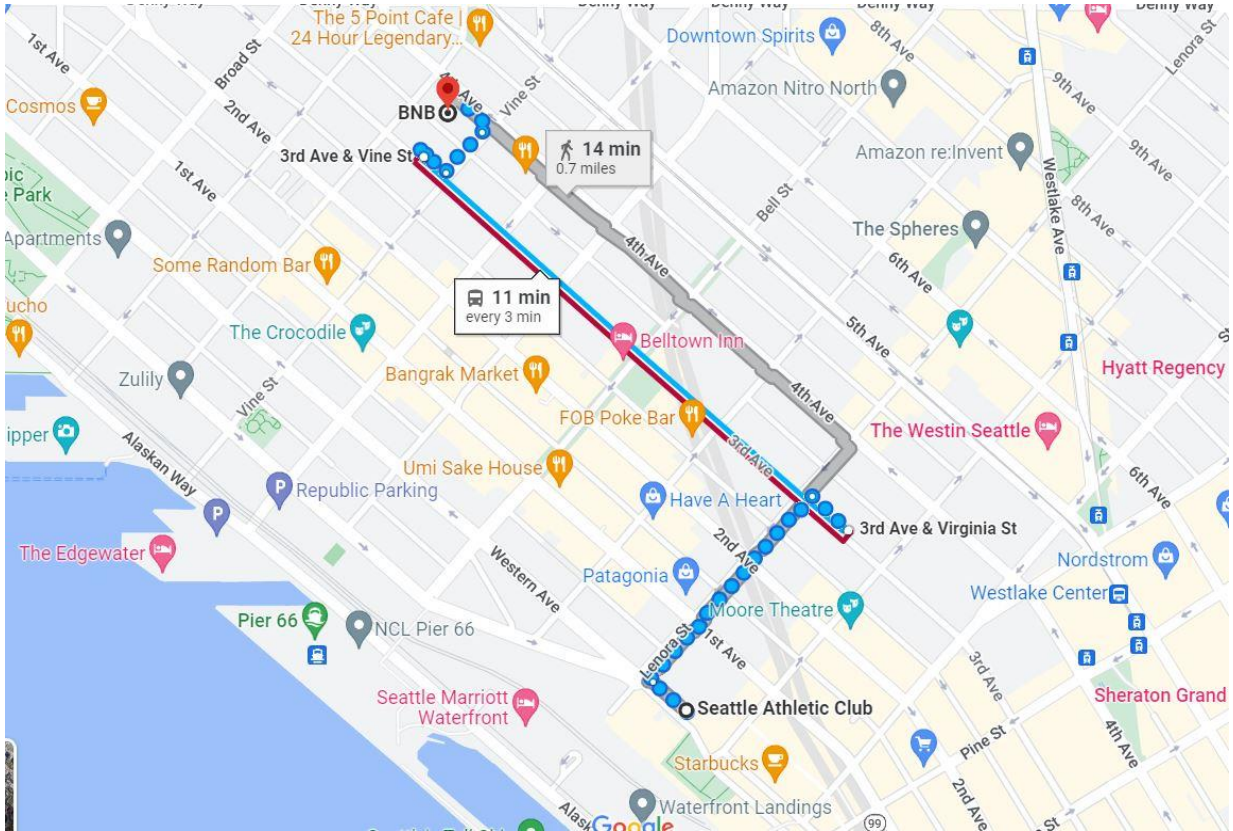

Figure2.2 (Site location) (Google maps)

This figure shows the accessibility 25 minutes far from the city center, Easy to arrive For the employees.

The Company is centrally positioned in the north of downtown. This building is 3716.12 msq it occupies two levels of a 1970s office building designed by Bora Architects and Airbnb Environments.

The challenge that the architects took was to reflect Airbnb's own culture while putting the previous aesthetic in line with the modern operational requirements of a global high-tech corporation.

2.1.3. Drawings



Figure2.3 (Ground floor plan) (Archdaily, 2019)

In this plan, we can recognize the relationship between the spaces, the emphasis on shared spaces and sitting places, the restricted number of private offices, and a spot for employees to take courses as they develop.

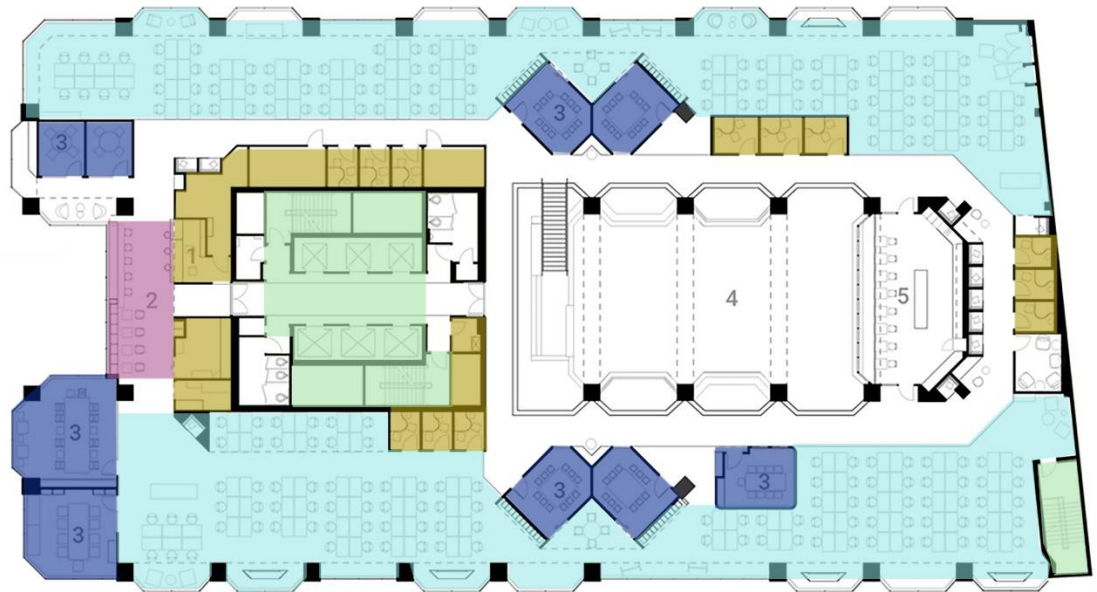

- 1 IT Help Desk offices
- 2 Lounge
- 3 Meeting Rooms
- 4 Atrium
- 5 Cafe
- Vertical Circulation
- Shared spaces-sitting areas

Figure2.4 (First floor plan) (Archdaily, 2019)

In this plan, we can recognize the High privacy in the private offices also the existence of the shared working places which develop the ideas and brainstorming with others. Also the spread of the meeting rooms and conference halls across the floor.



Figure2.5 (Interior spaces) (Archdaily, 2019)

This interior shots reflects the relaxed atmosphere which is suitable for working, sharing ideas and socialize.

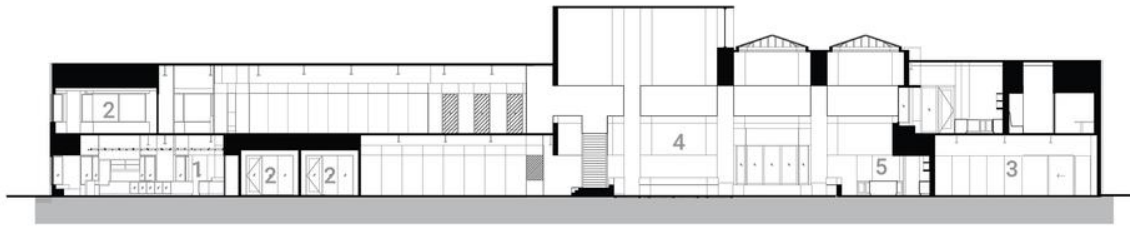

BUILDING SECTION

- 1 Reception / Teapoint
- 2 Meeting Room
- 3 Assembly
- 4 Atrium
- 5 Food Service Hub

Figure2.6 (Building Section) (Archdaily, 2019)

This section also explains the relationship between spaces and circulation.

Circulation and group activities are positioned in the double-height atrium, which is filled with a creative art piece, further activating this core area and allowing employees to observe and participate with the surrounding collaborative workplaces. Spaces grow progressively more private toward the periphery of the office floor to support the entire spectrum of professional activity.

So, because this company is in the software industry, visitors or people are not permitted to enter the building, and in addition to all of the security systems and security men, there is also privacy for the first floor because there are many private offices, and some of the tasks in this company require a high level of security.

2.2 Apple Headquarter

Apple Inc. (Apple) creates, manufactures, and sells smartphones, tablets, personal computers (PCs), portable devices, and wearable gadgets. Aside from software and related services, the firm also provides accessories, networking solutions, and third-party digital content and apps. Apple's product lineup consists of the portables. It provides a wide range of consumer and professional software programs, and accessories.

Apple sells and distributes digital material and apps through the Apple Store, App Store, among other channels. The corporation has operations in the Americas, Europe, the Middle East, Africa, and Asia-Pacific. (Apple Media Helpline, 2017)

2.2.1. Concept

When we talk about Apple headquarter in Cupertino-California, we're talking about the most expensive structure in the globe, which costs \$5 billion and took 8 years to complete, with 5 years just for construction.

It is a highly remarkable headquarters that is considered as a quantum leap in the information technology field since it has improved all elements that any firm, employee, or employer may confront.

Apple Park, envisioned by Steve Jobs as a hub for innovation and cooperation, is replacing miles of asphalt sprawl in the heart of the Santa Clara Valley into a refuge of green space. The campus' ring-shaped, 2.8 million-square-foot main structure is totally covered in the world's biggest curved glass panels.

It is a skyscraper with a very futuristic design. It is located in Cupertino, California, and is the tech giant's second campus.

Its form is a giant ring, demonstrating Apple's commitment to its groundbreaking design and the future of technology. And it is officially known as the ring it respects human scale since it is a four-story building.

As it is an infinite loop building, they took safety precautions, and it is also earthquake resistant. (Apple Media Helpline, 2017).

2.2.2. Designer Vision

Because Steve Jobs is concerned about sustainability and air quality, he created the headquarters as a park within a park, and he examined all things of this headquarter to fit the sustainability.

At first 20% of the site was landscape and the rest was asphalt parking, they changed it and make it 80% landscape, there was 3700 trees and they doubled it into 6000 trees and by asking how they did that and what was the solution for the parking which should fit for 12000 people. The solution was to put the parking underneath the main building. (Jobs, 2011)



Figure 2.7(Site Trees before and after construction) (archdaily, 2011)

This figure shows how the architect preserve and increase the number of the trees, and design the campus as a field.

Table 2.1 (Comparing percentage) (Steve Jobs conference, 2011)

Comparison element	Today	Tomorrow	Percentage
Employees	9500	13000	+40%
Space	2.6 M	3.1 M	+20%
Landscape	1.7 M	5.9 M	+350%
Trees	3700	6000	+60%
Surface Parking	9800	1200	-90%
Building Footprint	1.4 M	1 M	-30%

This table shows Steve Jobs' estimates for the future campus, comparing the old and new campuses, with percentages growing or decreasing.

According to Jobs' thinking and intentions, they will start to break ground in 2012, and they will move to the new campus in 2015. (Jobs, 2011)

But in 2017, the project completed construction and formally moved its staff into it.

Steve Jobs hired the greatest architects in the world to come up with a design to hold 12000 people in a building, and the aim was to break the monotony, and increase the employees' productivity. (Jobs, 2011)

It was designed by Foster and Partners which was created by Norman Foster in 1967 as a British architectural, engineering, and integrated design practice. It is the second largest architectural firm in the United Kingdom. (Hickman, 2020)

Norman Foster was the one who could translate Steve's ideas into a project,

The concept around this transformation that they did from the old site to the new one, was a very interesting transformation so it was an imposed site covered with asphalt with little landscape and they turned it into 80% of the site as a landscape with increasing the number of employees so its 30% more people on this site. (Foster, 2020)

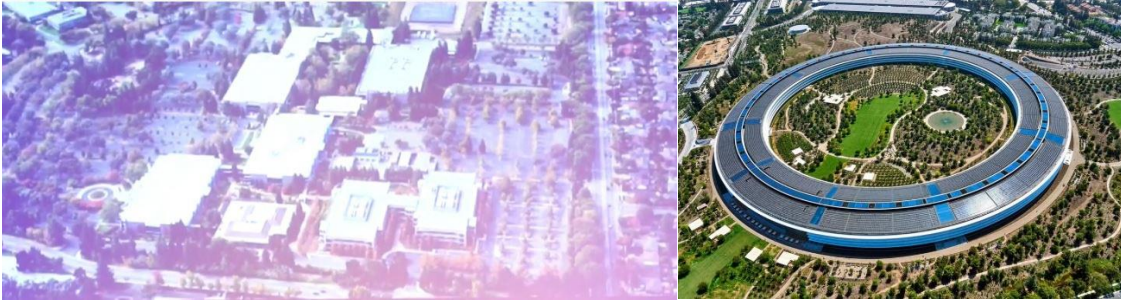

Figure 2.8 (Comparing site before and after construction) (Foster, 2020)

This figure compares the site before and after Apple park, and how it looks nowadays like a orchard.

Physically, it is a very large building, but you don't feel it when compared to the old individual buildings, where the human scale was not taken into consideration, but here in the new campus, which is the infinite loop, you don't feel it, so if you were in the heart of that circle, you can see the building as a horizon, and if you were outside the circle, the building will be incident to the landscape, and the number of stories and shape of the building plays a role in investigating this . (Foster, 2020)

2.2.3. Site Location

Project Location

Apple headquarter is located in Cupertino, California.

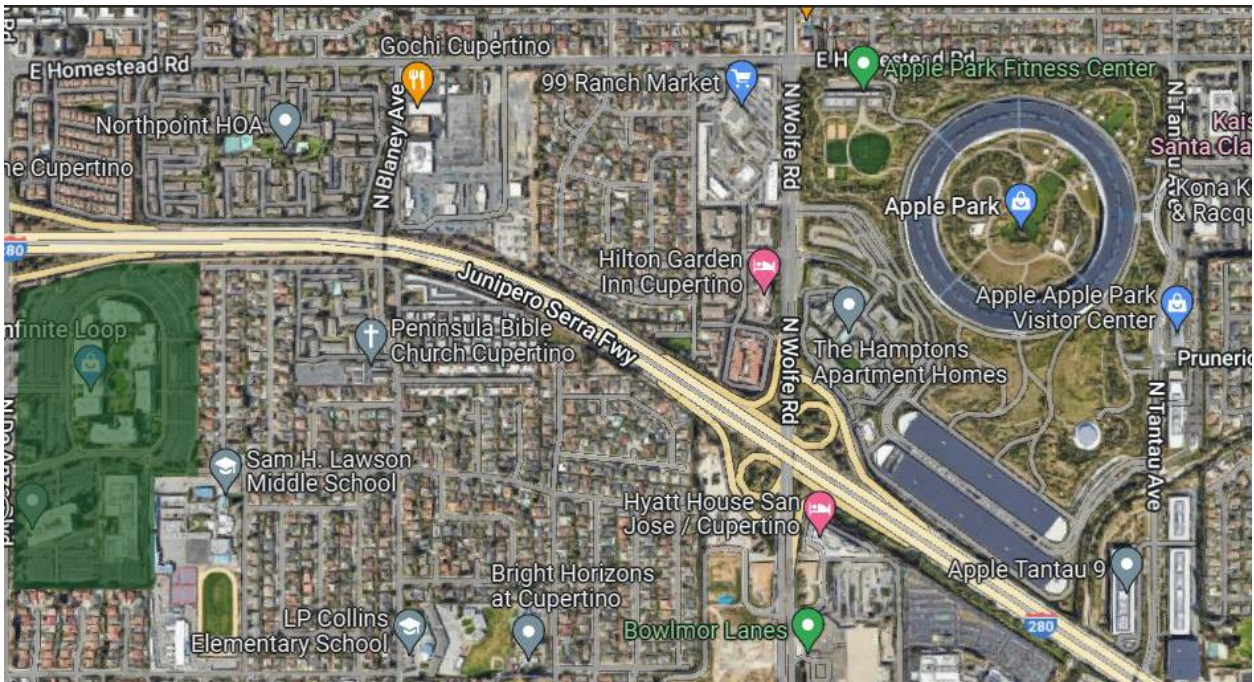

Figure 2.9 (Apple's old campus site) (Google maps, 2022)

In this figure we can determine the old campus location, choosing the city of California was a no-brainer because it is the origin of Steve Jobs, but choosing this plot had a lot of meanings for him.

According to Steve Jobs, Apple has always been located in Cupertino, California. It began in a small office park and later expanded to buildings in Danns-California that could hold 2600-2800 employees. As the firm grew and they ran out of space, they decided to establish a new campus to unite the company.

So Apple bought a land parcel to move to it and this land parcel was special to Steve Jobs because, as he stated when he was 13, Hewlett-Packard (HP Company) were his idols, and he was working as a summer intern at HP company, and at that time they were building their new campus in that land, and by then the Company started shrinking, so they chose to sell it, and Apple bought it, as well as adjacent property that used to be apricot trees and apricot orchards, the campus occupies an area. So they could stay in the city where they were founded in Cupertino. (Jobs, 2011).

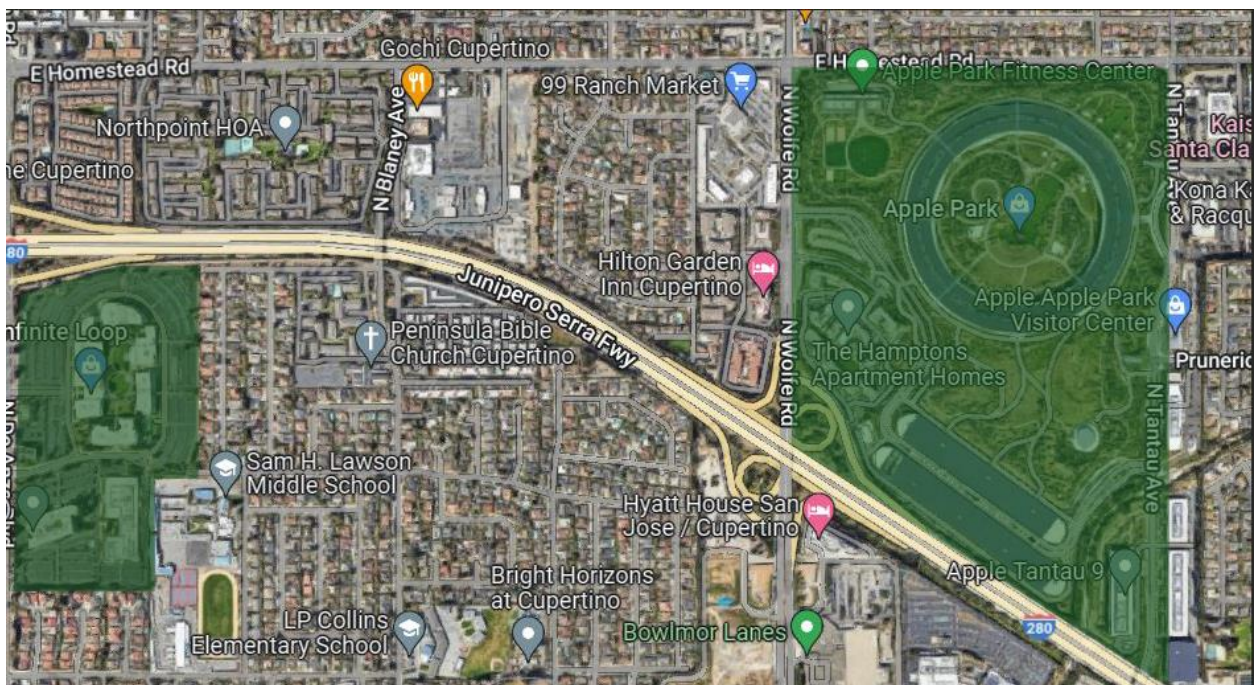

Figure 2.10 (Apple's new campus site) (Google maps, 2022)

In this figure we can see the old and new site for Apple headquarter.

2.2.4. Plans

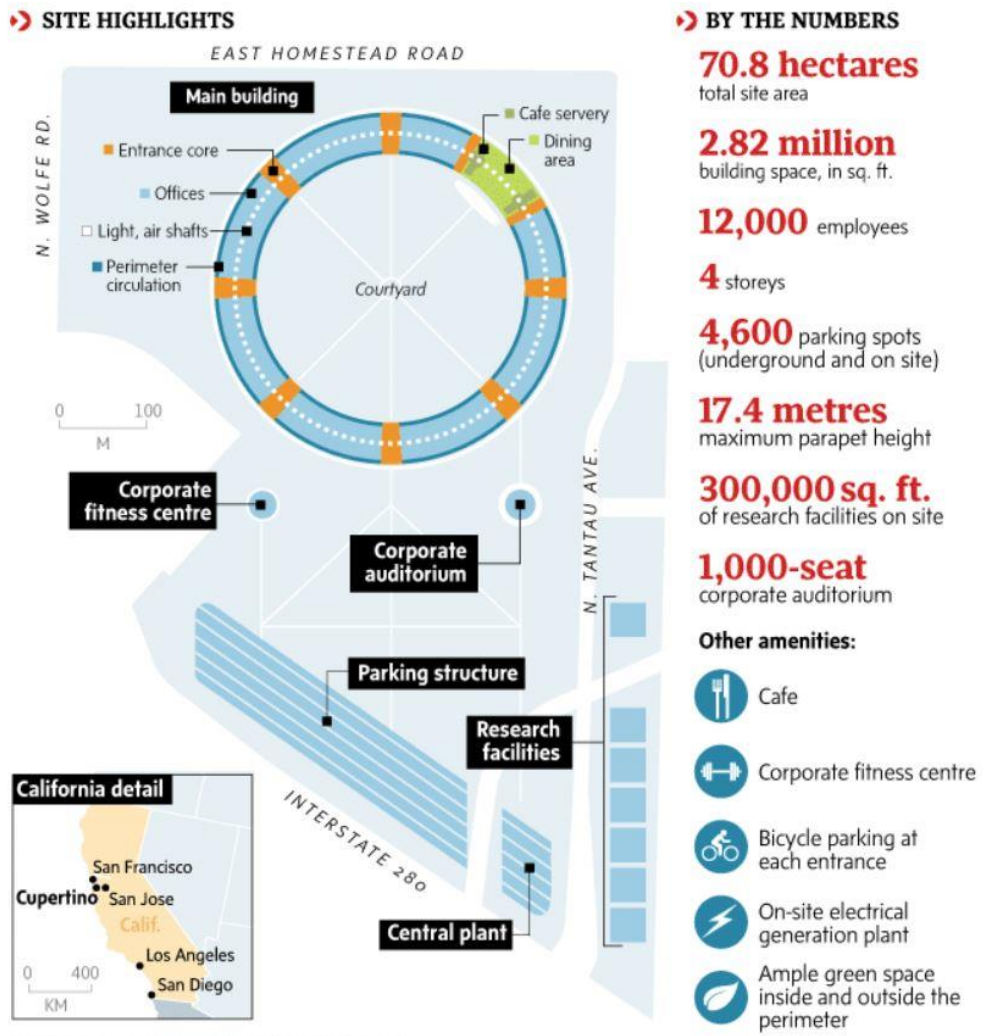

Figure 2.11 (Site details) (matthew bambach, the globe and mail, source: Apple, 2022)

This chart illustrates details about the site, including how the amenities are arranged.

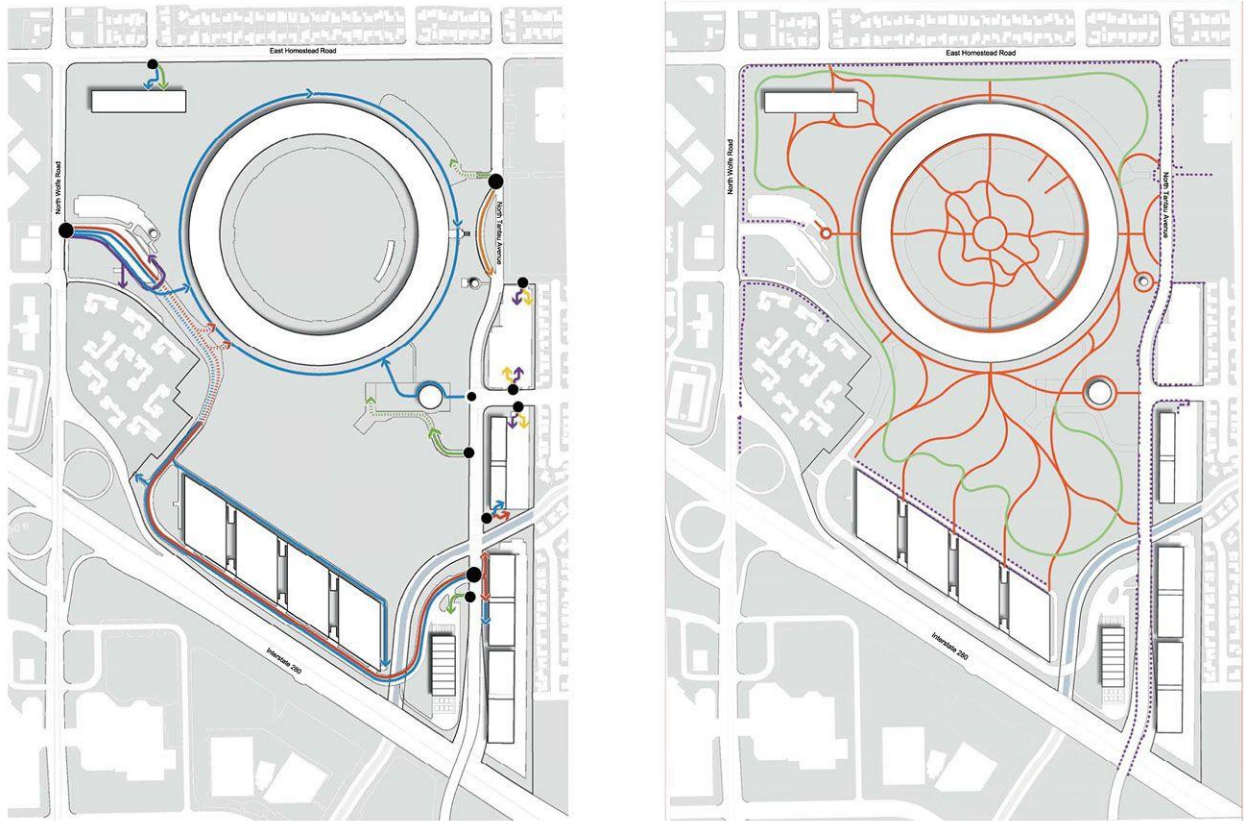

Figure 2.12 (Site circulation) (archdaily, 2011)

In this figure, the first image shows vehicle circulation, such as visitors' access in purple, Apple transit center access in orange, employee access above and below ground in red, emergency center access in light blue, service access in green, and theater visitors' parking access in yellow.

As we can see they separate the accesses so it will be more arranged and less imposed, so by being in the site you don't see a lot of vehicles.

On the right, this image depicts pedestrian circulation, with purple representing the public sidewalk, red representing private walkways, and green representing a private jogging route.

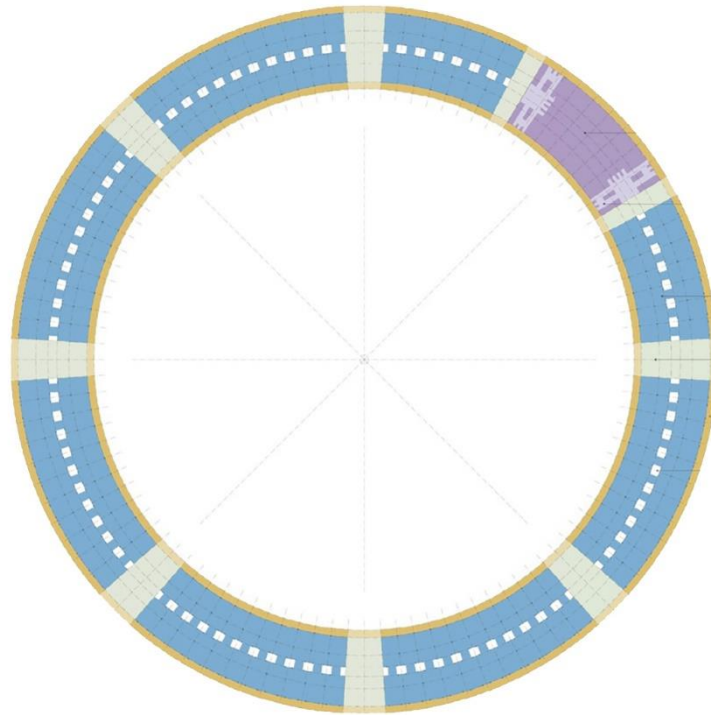

Figure 2.13 (Ground Floor) (Archdaily, 2011)

As we can see on the ground floor, leading to the entrance, services and horizontal circulation are in the green color, with a restaurant in the pink color, and the rest space is open working space to encourage free-fall ideas. This also allows employees to mingle and avoid burnout from working all day.

As shown in the references, the basements include the parking and services which are two floors, the ground floor contains: Shared Offices, entrance core, Dining area, and services.

The first, the second and the third contains: Private Offices, Shared Offices, kitchenette, storage and services.

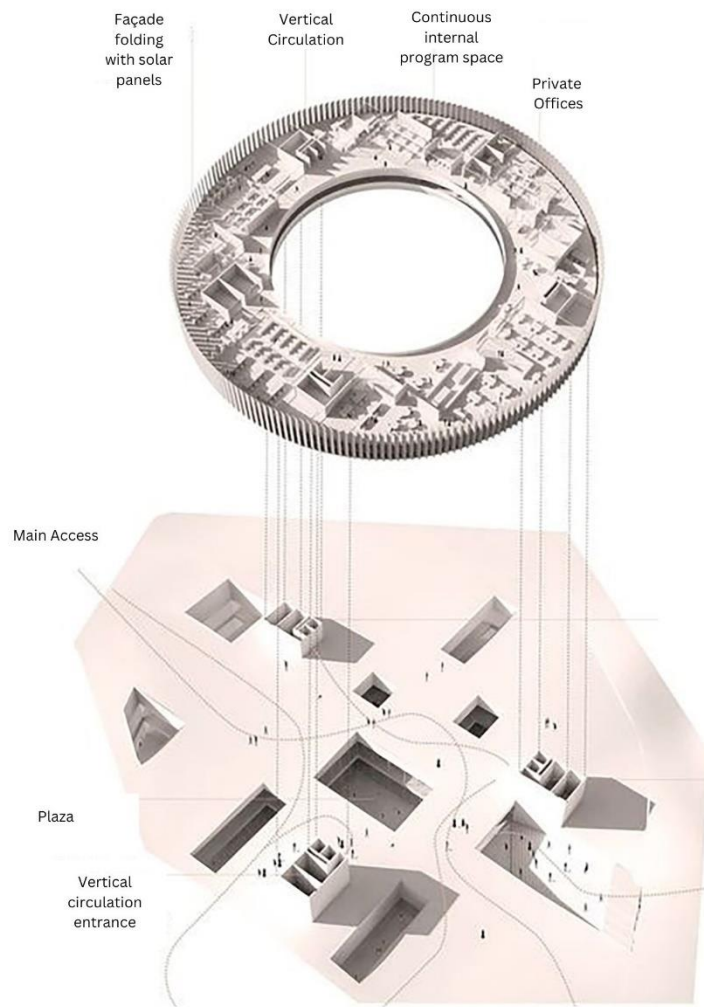

Figure2.14 (Headquarters' Circulation)(Archdaily, 2011)

This figure shows the Accesses to the building, plaza and the vertical circulation.

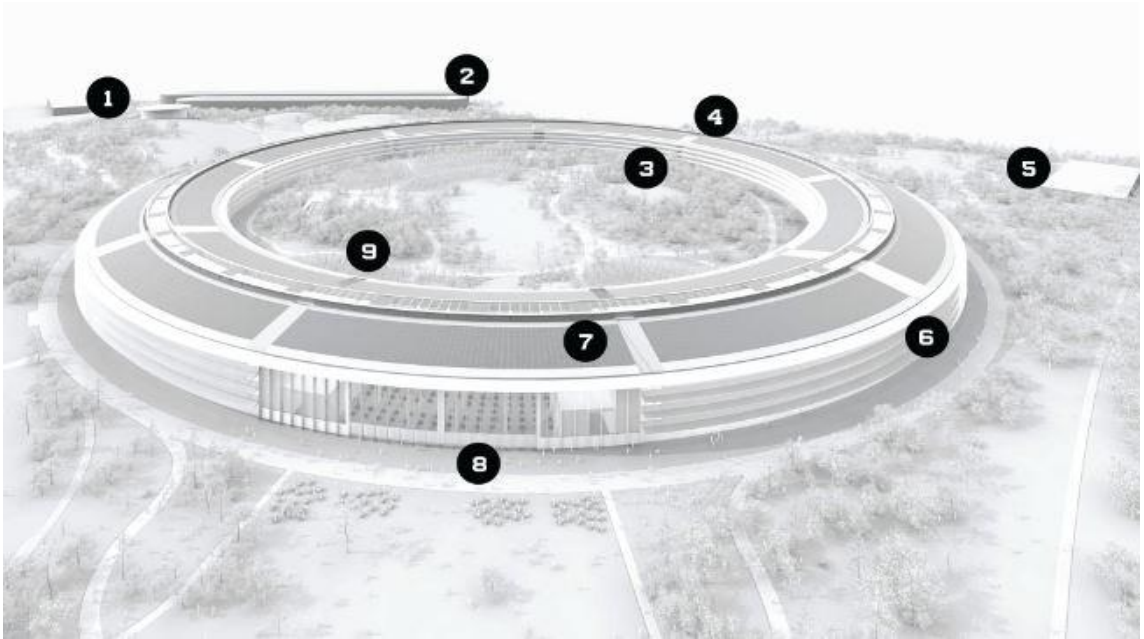

Figure 2.15 (Campus Isometric) (Matt Hickman, 2020)

As this figure shows the component of the Apple Park and below some important components will be explained.

6- Horizontal Shades:

'Eyebrows of the building' As Norman Foster called them.



Figure 2.16 (Horizontal shades) (Foster+Partners, 2018)

These photos show the component of the structure provides shading while also reflecting light deep within the building, so the external part virtually disappears, and you can see the underside of that which is reflecting the landscape and bringing it in. (Foster, 2020).

7- Solar system

As a technological company, all of the staff use computers rather than electricity; if the company is dependent on the grid and power goes out, the entire operation will come to a halt, including the Research and Development Building.

Their major source of energy was the energy center, which allows them to create power using natural gas and other cleaner and less expensive methods. To be more sustainable, the power from the solar panels accounts for 75% of the building's energy consumption, thus the 2.8 million square foot ring will run solely on sustainable energy, mostly from the 805,000 square foot solar arrays on campus. (Foster, 2020)

8- Café and restaurant

There is just one restaurant and multiple cafés. So staff have more opportunities to engage with one another and debate new ideas. (Jobs, 2017)

Visitors Center

The only building that visitors without a permit can enter, It is a single building divided into:

- 1- A 10,000-square-foot Apple store sells all items as well as souvenirs.
- 2- Another portion comprised a 23-hundred-square-foot bistro.
- 3- And augmented reality experience area where customers may virtually tour the whole facility (Tech Vision, 2020)

2.2.5. Project Structure and Construction

Glass Wall:

Because this building is a ring (circle) and is wrapped with glass, the glass bends all the way around the circle, and they benefit from their prior expertise from retail buildings across the world for an architectural function. (Jobs, 2011)

When it came to expenses, having curved glass was one of the most expensive since it was custom-made for this project, but it was also used as supporting beams, as in Steve Jobs theater, because there are no visible supporting beams in this construction, they used this glass as one, and that's one of the reasons that this Theater won the 'Structural Artistry' award in 2018. (Duncan Sinfield, 2020)

Having the glass wrapping the building was for creating a relationship with nature, having natural light, a good view, and changing climate that will be healthier. Also a way to mix individual workstations into larger social areas, so they can discuss ideas and be more creative and socialized. (Foster, 2020)

Ventilation:

while foster was talking about the fusion of social dimension and also technology and the quest for a healthier building then at the top of that sheet of glass there is a junction and there is a movement of air that controls the flow of air, there are also filters in terms of dust or insects although it is a glass building.

The electricity and the services are also supplied out invisibly through the joints between the glass. (Foster, 2020)

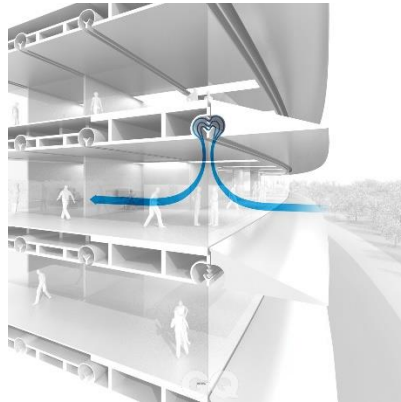

Figure 2.17 (Ventilation) (Foster, 2020)

In this figure the ventilation process is shown.

2.2.6. Apple's importance for the city (California)

As Steve Jobs mentioned, Apple pays the most taxes for the city, and secondly, Apple hires talented people of all ages: college students, graduates, and people in their 50s and 60s, so having a company to hire and practice people in it would be good for the city and its residents, and they go to work even by bikes or buses, which the company provides buses that run on biodiesel fuel so they are the cleanest buses plus a lot of trees, and they go to work even by bikes or buses. (Jobs,2011)

Chapter Three
Project Program

3.1 Functions

By talking about a technology corporation, the main activity there is working and the main spaces and facilities is for the employees.

The secondary activity is for the clients, customers, trainees, and maintenance workers.

Employees are becoming increasingly crucial in office job organization, and their performance is enhanced by factors such as the company's image (corporate identity), the design of facilities for breaks and relaxation, and the unique setup of workplaces. (Neufert Architects' Data, 4th Addition).

3.2 Departments and their Functional Requirements

3.2.1. Administration

In this sector it has the general management, and it's responsible on the administrations for every department as the manager of the software, hardware and the training center.

Functional requirements:

- Users:
 - Accountant
 - Marketing
 - HR
 - Security
 - Public relations
 - Secretary
 - Receptionist
 - And a general director that is responsible for software, hardware and the training center administrations.

The main physical spaces that the employees will use are:

- Reception
- Private Office
- Services
- Meeting rooms
- Security room
- Shared working space

- Equipment
 - For the reception and lobby the equipment are:
Reception counter, waiting area includes seats.
 - Offices:
Desks, computers, seats and cupboards.
- Vehicles
Cars & public transportation.

3.2.2. Hardware department

The hardware department in this project is responsible for product trade, maintenance, and exhibit.

Functional requirements:

- Users:
 - Here there is several users in this sector:
 - The costumers
 - The employees, whom are: the marketing manager, Accountant, HR employees, exhibition manager, services employees, maintenance workers and security.
 - The workers for transporting and loading.

As the activities for those users are various, so we need multiple spaces to complete these activities, which are for the costumers viewing the products, buying, or giving a product back to be maintained. And for the employees the activities are displaying, marketing the products, maintaining and receiving new products.

The main physical spaces that the costumers will use are:

- The reception and lobby
- The exhibition
- Cashier
- WCs

The main physical spaces that the employees will use are:

- Reception
- The exhibition
- Cashier
- Maintenance sector
- Offices
- Stores
- Services (WCS, and kitchenette)

- Equipment

-For the reception and lobby the equipment are:
Reception counter, waiting area includes seats.

-For the exhibition:
Tables for exhibit, screens, and projectors.

-For the cashier:
Cashier counter, computer, cash machine.

-Maintenance sector:
Desks, cupboards, and maintenance equipment.

-Offices:
Desks, computers, and cupboards.

-Stores:
Cupboards and spaces for the machines.

- Vehicles

This sector has three entrances, parking spaces: one for employees, one for guests, one for loading items into the stores and drop off area.

And for the vehicles' types, the ones that this sector need are: trucks, cars, taxi, public transportation and waste collector truck.

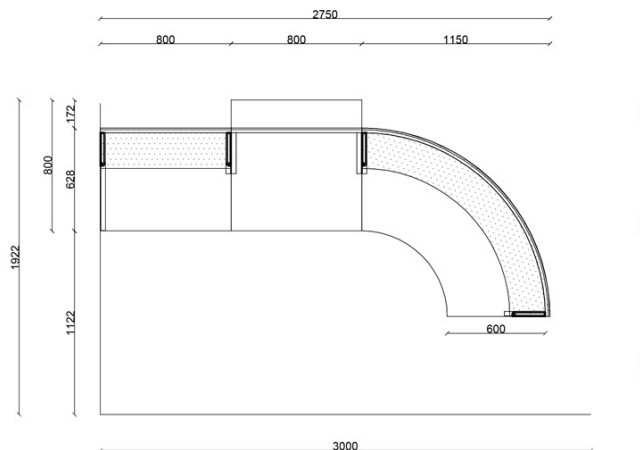

Figure3.1 (reception counter dimensions) (Neufert Architects' Data, 4th Addition)

This figure shows the standards of the reception counter dimensions

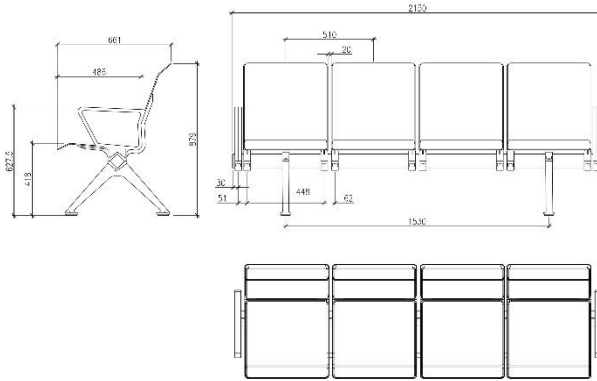

Figure3.2 (Seats dimensions) (Neufert Architects' Data, 4th Addition)

This figure shows the standards of the Seats dimensions.

3.2.3. Software department

A multiple important things should be taken into consideration, first the high privacy high security, as this department is so sensitive because of the costumers' private data inside this department. So no visitors are allowed to enter this sector.

Functional requirements:

- Users
The users of this department are confined to employees, and their main activity is working in an interesting atmosphere, as known the employees in this sectors mostly are the programmers, whom been the entire day in front of the screens doing codes and solving equations, so there should be a thoughtful design.

The main physical spaces that they will use are the offices, various types of offices:

- Private office
- Meeting rooms
- Conference hall
- Shared working areas
- Services
- Archive room
- Servers floor

And to complete this activity which is 'Working and focusing' they need some supportive functions, which are:

- Sitting areas/breakout area/shared places
- Activity rooms

By discovering how to provide a suitable atmosphere for the employees to increase their productivity, creativity, and to have a healthier life, I found out that some of the needs that should exist are these elements:

- relation with the nature
- green areas
- natural sun light
- calmness

- Equipment

Private offices:

The equipment needed for this department are mostly smart desks, cupboards and computers.

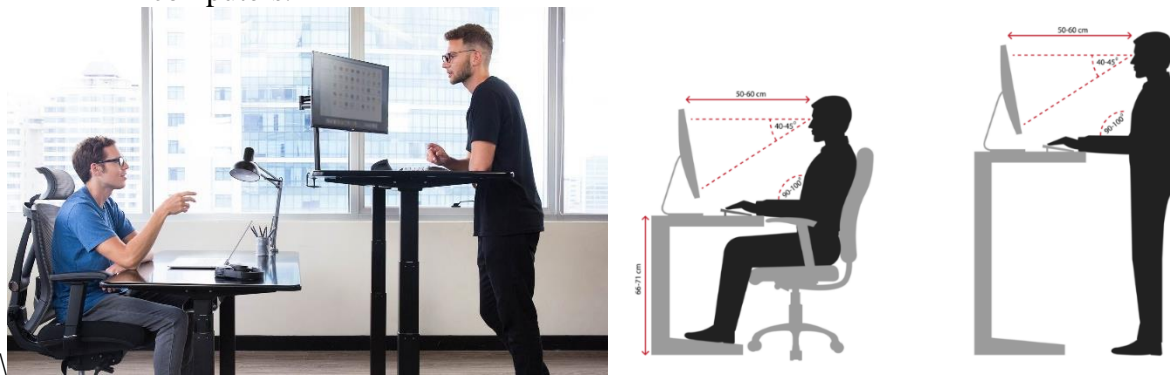

Figure 3.3 (Smart desk)(Mytechlogy)(cynthia2018)

This figure shows the smart desk in there two shapes and its dimensions.

Meeting rooms and conference halls:

Meeting table, projector and whiteboard.

Shared working areas:

Multiple shared desks and couches

- Vehicles:

For this department the only vehicles that used for it are the staff cars, taxis, public transportation and waste collector truck, so we need a staff parking, and a drop off area.

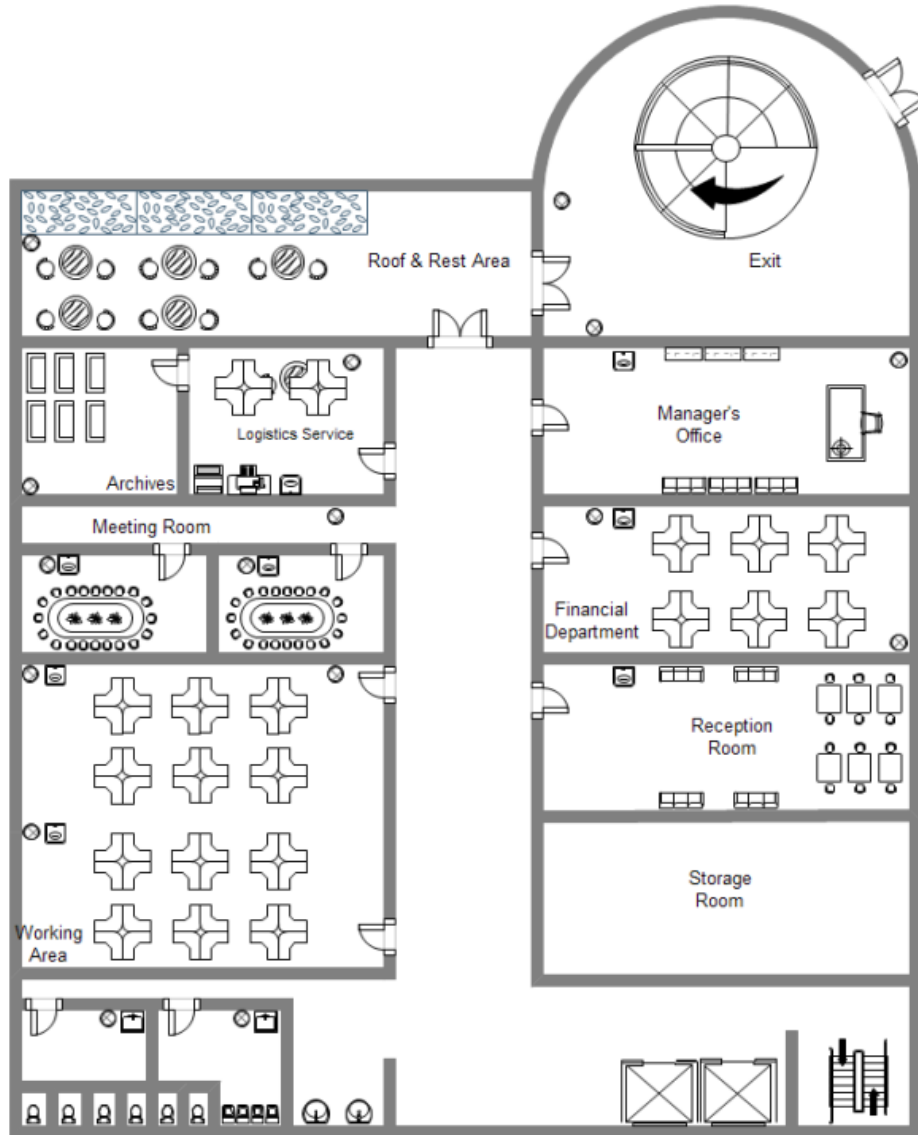

Figure3.4 (software department plan) (James, 2022)

This figure shows software department plan sample.

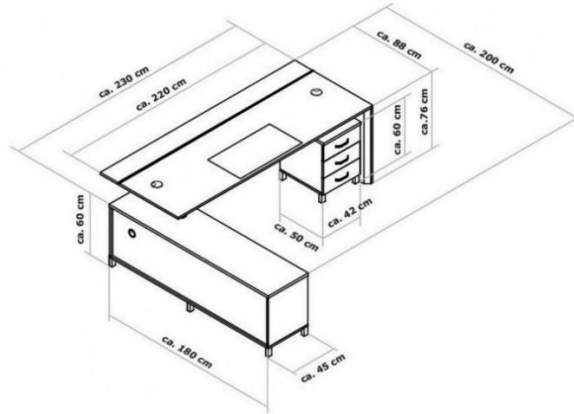

Figure3.5 (desk dimensions) (James, 2022)

This figure shows desk dimensions.

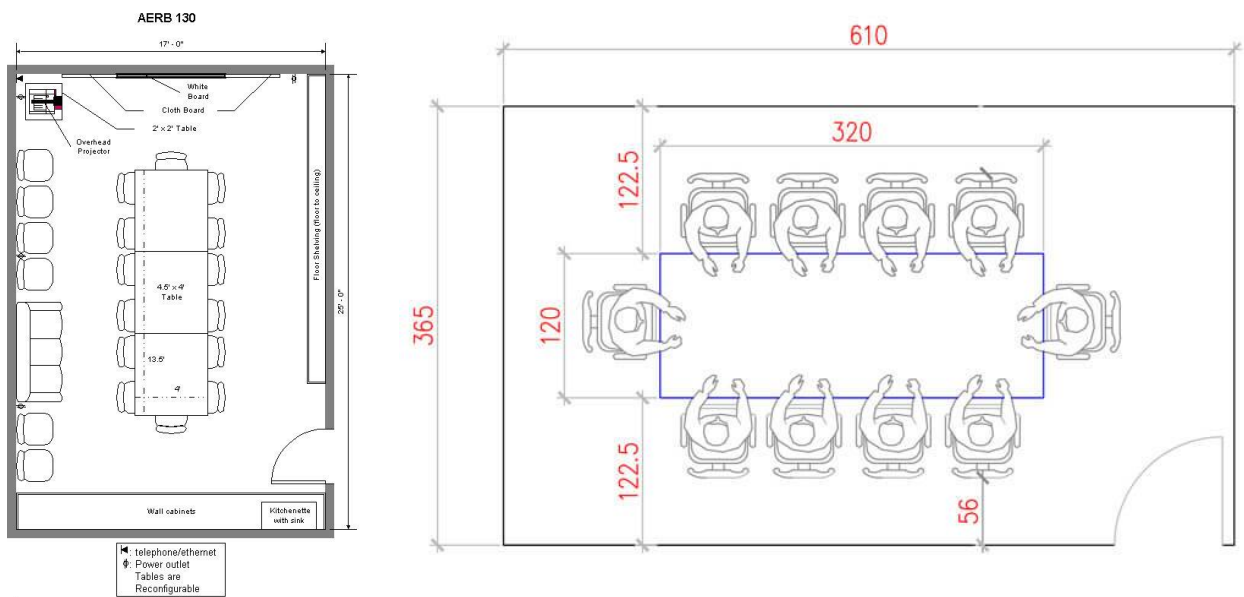

Figure3.6 (meeting room dimension) (James, 2022)

This figure shows meeting room dimension.

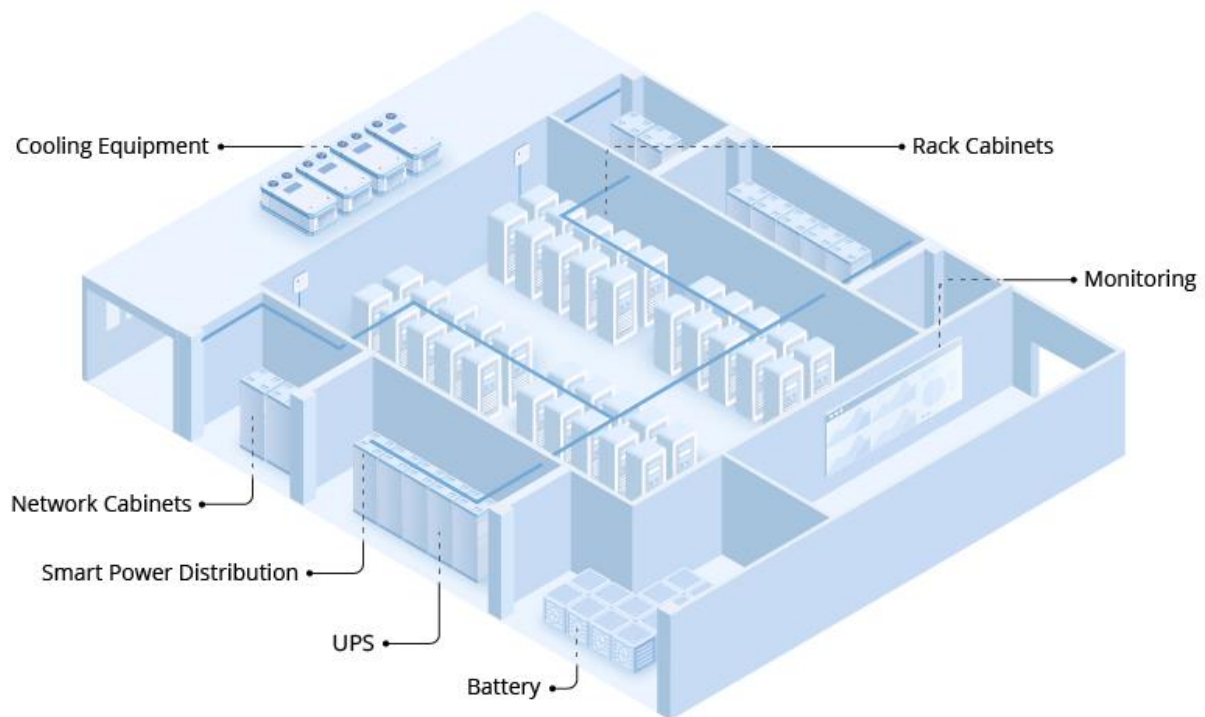

Figure3.7 (servers' floor) (Rameez Arif, 2022)

This figure shows a sample for the servers' floor.

3.2.4. Training center:

Functional Requirements:

- Users:
 - Trainees/Instructors
 - Trainers (students and employee)
 - Employees
 - Cleaners
 - Maintenance workers

The physical spaces that they will use are:

- Reception and waiting area
- Halls
- Computer Labs
- Offices
- Meetings room
- Services

- Equipment:
 - Computers
 - Desks
 - Tables
 - Cupboards
 - Screens and projectors
 - Chairs and seats
- Vehicles
 - Parking for the staff cars, for the trainers and for the waste collector truck.
 - Also a drop off for the taxis and the public transportation.

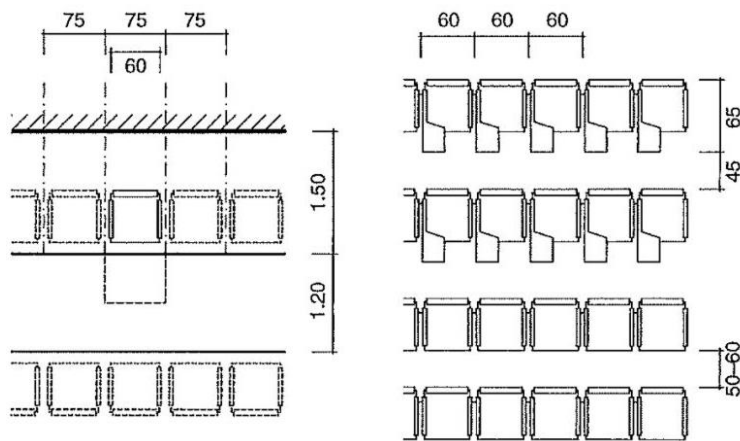

Figure 3.8 (conference hall dimension) (Neufert, 4th edition)

This photo provide conference hall in training center dimension.



Figure3.9 (the Training center sample)(Dimensions.com)

This figure shows a sample for the Training center sample.

3.2.5. Cafeteria:

Functional Requirements:

- Users:
 - Employees
 - Trainers

The physical spaces that it will contain:

- Eating Hall
- Kitchen
- Storage
- Services

- Equipment:
 - Tables
 - Food counter
 - Café corner
 - Oven
 - Fridges
 - Cupboards
 - Kitchen equipment

- Vehicles
This sector needs a parking for loading items into the stores.

3.2.6. Shared places: (Supportive function)

Functional Requirements:

- Users:
 - Employees
 - Trainers

The physical spaces that it will contain:

1. Interesting setting areas.



Figure3.10 (Workstation) (GURGAON,2018)

These photos shows some creative shared areas for working.

Table 3.1 (space requirements for workstation) (Neufert, 4th edition)

Area (m ²)		Range	Average	Total
Workstation	Immediate workstation	11–15	13	15.5
	Additional area (consulting, storage)	1.5–4.2	2.5	
Subsidiary areas	Sanitary facilities	0.6–0.8	0.7	9.0
	Conference/training	0.3–1.0	0.6	
	Archive	0.4–1.0	0.6	
	Stores	0.4–1.5	0.6	
	Canteen, cafeteria, tea kitchen	0.6–1.6	1.1	
	Entrance area	0.2–0.7	0.4	
	Supply and disposal	0.5–1.5	1.0	
	Post room	0.3–0.5	0.4	
	Server room	0.5–1.5	1.0	
Garage parking	0–13	2.6		
Building	Construction area	1.9–3.8	3.0	10.5
	Building services	2.4–4.6	3.0	
	Traffic area	2.2–6.0	4.5	

The previous table shows the Average gross space requirements for workstation.

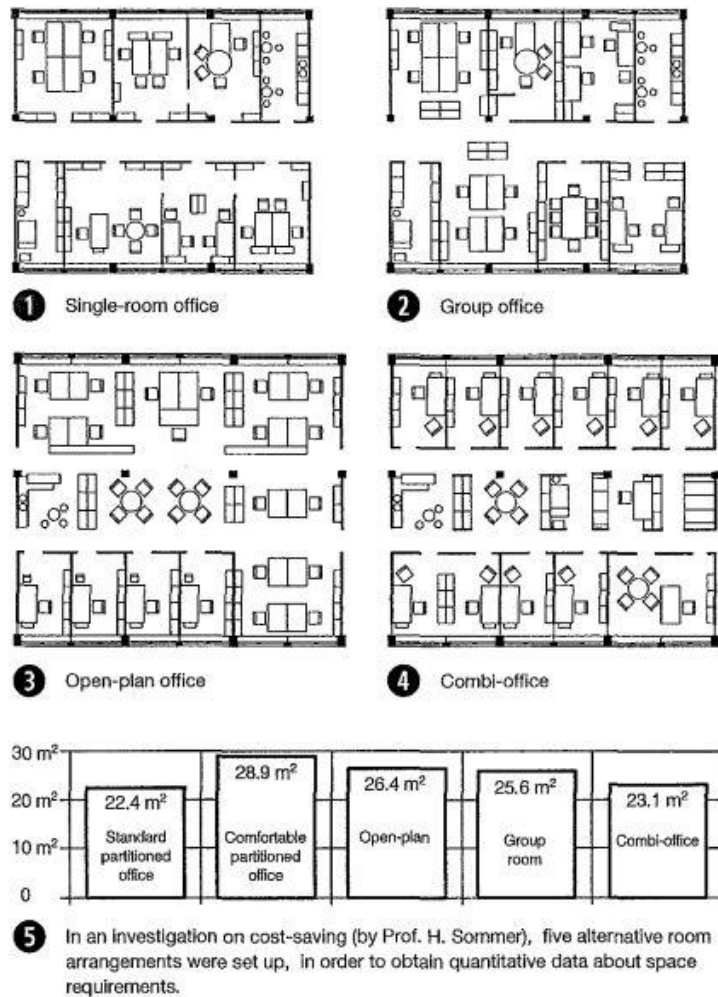

Figure 3.11 (office room types) (Neufert, 4th edition)

This figure shows some types of office room types.

2. Activity rooms:

Which includes instruments, boarding games, PlayStation, and any other games used to relieve energy.

- Equipment:
 - Instruments
 - Smart desks
 - Settings' cushions
 - Swings
 - Tables
 - Creative sitting blocks/steps

3.2.7. Services

Physical spaces that it will include:

- WCs
- Kitchenette
- Storage

Functional Requirements:

- Users for the WC:
 - Employees
 - Trainers
 - Costumers
 - All building's users

But for the kitchenette and storage the users are the employees

- Equipment:
 - Kitchen equipment
 - Cleaning equipment

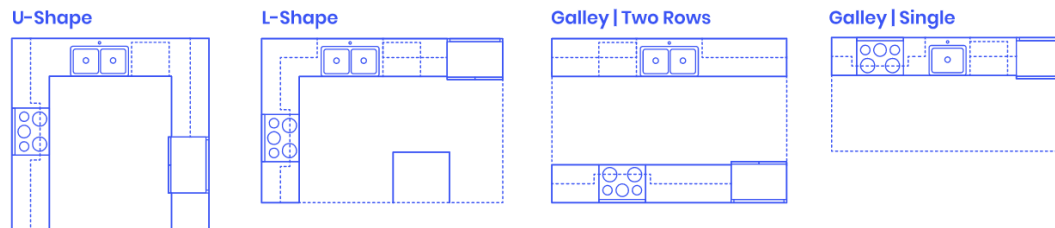

Figure3.12 (kitchenette types)(Dimensions.com)

The previous photo shows different shapes of the kitchenette types.

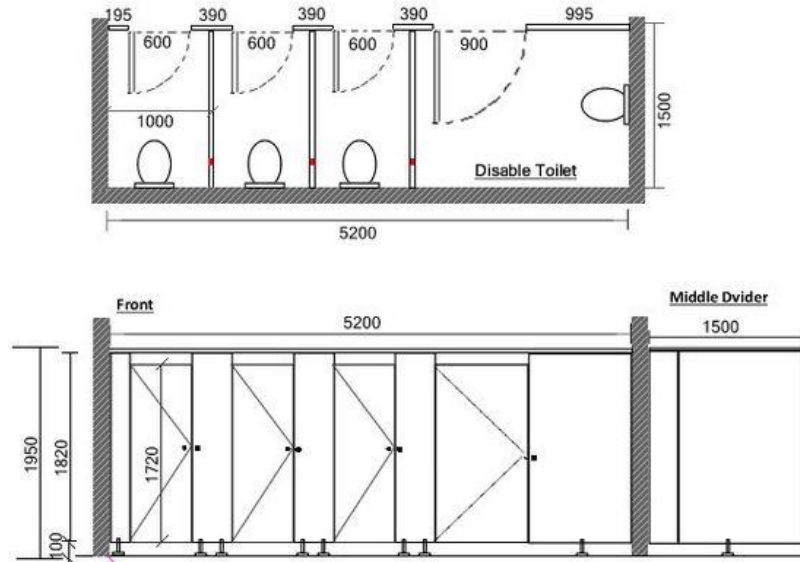

Figure 3.13 (Dimensions of toilet units) (Neufert, 4th edition)

This figure shows dimensions of toilet units.

3.3 Operational requirements:

3.3.1 Security system

In this project the security system is one of the most important systems. By enforcing a comprehensive security system you can rest assured that your property is safeguarded at various levels.

There are three types of security, which are: Data security system, building security system, and security workers.

Systems For the security:

- Access control system

Access control is the process of identifying a person and deciding their level of security access to electronic systems or physical facilities based on the organization's rules and procedures. Modern access control systems recognize a person, verify them by examining their identity, and then provide that person with only the key to the door or digital resource that they require.

Access is given through a series of processes to ensure that this user has access to the requested resources.

Access control types:

1. This sort of access control is very useful for time attendance and fingerprint identification.

Instead of a card system, the biometric system employs a fingerprint method. This kind not only allows input but also displays the data of the entering individuals. For their regulated zones, many companies, organizations, and private buildings utilize biometric access control. (Farquhar, 2022)



Figure3.14 (access control system) (ptraccess)

This photo contains the access control system.

2. Proximity access control

This kind is used in most offices, industries, banks, and commercial buildings since they demand a strong security system. It has 50 time zone options and 5 open door groupings. (Farquhar, 2022)



Figure3.15 (Proximity access control)(agtelecom)

This photo contains the Proximity access control.

- Video surveillance

Video surveillance protect the building against theft, incursion, fire, flood, or burglary. To transmit and store the footage captured by all security cameras in a particular system, a central video recorder is required. DVRs originated from previous VCR versions, but NVRs represent the next phase in video recording technology advancement. (Sean peak, 2022)

- Intrusion alarm
- Electronic sensors

3.3.2. Energy System

As this firm depends on energy, and it can't be able to use without electricity for the energy system, alternative energy should be taken into consideration.

So as an alternative source we can use solar panels system (PV),

1. Grid-tied Solar System

Grid-tied solar systems are linked to the electrical grid of the local utility company. Grid-tied solar owners get the benefits of a solar system while still having the security of their utility provider, because they can connect into the grid if solar energy output is low.

2. Off-Grid Solar System

Off-grid solar systems are not linked to the power grid and rely on battery storage devices to meet energy demands.

3. Hybrid Solar System

A hybrid solar system is one that is both grid-connected and off-grid. These systems are linked to the electricity grid and have their own battery storage system. Hybrid systems are the most adaptable choice, with the flexibility to draw energy from the grid or from the battery when energy demands exceed energy output. (ILLUMINATING THE PATH TO SOLAR, 2022)

3.3.3. Circulation system:

1. Elevators system:

One can be used by visitors and employees, and the other one is allowed to be used by the employees only.

Used by employees and visitors.

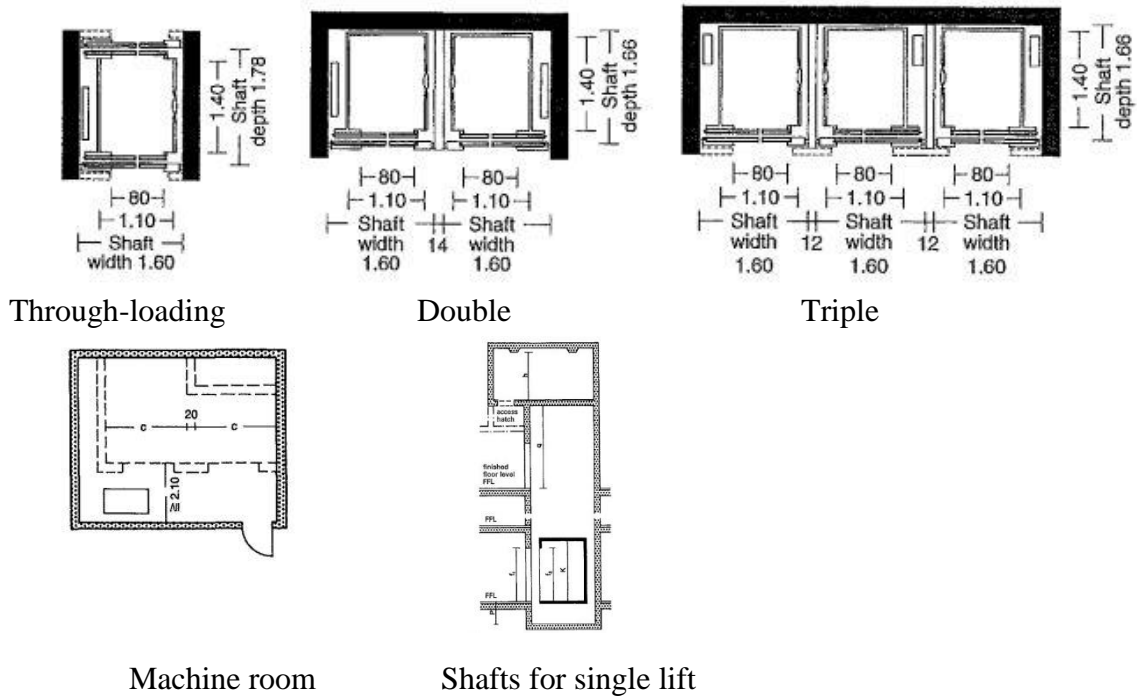

load capacity	kg	800				1000 (1250)				1600			
		0.63	1.0	1.6	2.5	0.63	1.0	1.6	2.5	0.63	1.0	1.6	2.5
min. shaft width	c	1900				2400 (2600)				2600			
min. shaft depth	d	2300				2300 (2600)				2600			
min. shaft pit depth	p	1400	1500	1700	2800	1400	1700	2800	1400	1900	2800		
min. shaft head height	q	3800		4000	5000	4200		5200	4400		5400		
shaft door width	c ₁	800; min. 900				1100				1100			
shaft door height	f ₁	2000				2100				2100			
min. area of machine room	m ²	15		18		20			25				
min. width of machine room	r	2500		2800		3200			3200				
min. depth of machine room	s	3700		4900		4900			5500				
min. height of machine room	h	2200		2800		2400	2800		2800				
car width	a	1350				1500			1950				
car depth	b	1400				1400			1750				
car height	k	2200				2300			2300				
car door width	e ₂	800; min. 900				1100			1100				
car door height	f ₂	2000				2100			2100				
permissible no. passengers		10				13 (16)			21				

Figure 3.16 (elevators dimensions) (Neufert, 4th edition)

This figure shows the types of the elevator with its dimension that suits the specific usage.

2. Stairs:

Particularly in the software sector, should be interestingly constructed to encourage employees to use them, as they sit at their desks all day.



Figure 3.17 (Archdaily)(Florian, 2022)

This photo shows how the stairs can encourage employees to use them.

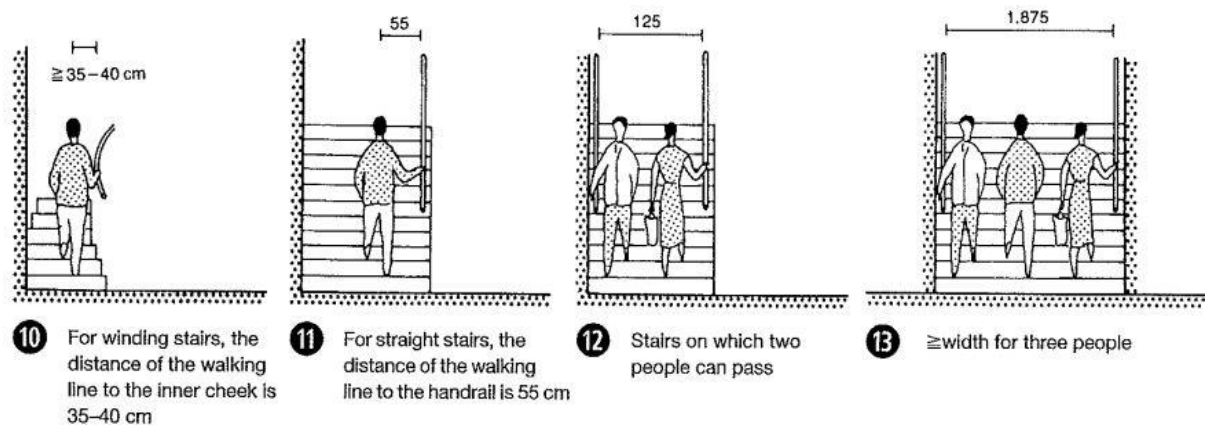

Figure 3.18 (stair dimension) (Neufert, 4th edition)

This figure shows the dimensions of the stairs' types.

3.3.4. Emergency system

Is very important as there is a lot of electricity, so emergency exit pathways are essential because they give a clear, safe path out of a building in the case of an emergency or crisis. During a catastrophe or crisis, first responders such as fire or police may also use emergency exits to access a building. Identifying and maintaining emergency exits and emergency escape routes is a critical aspect of workplace safety.

Emergency Response Plan (EAP). To assist in keeping workers safe, the U.S. The Occupational Safety and Health Administration (OSHA) prepared an information sheet regarding these critical escape routes.

An emergency exit contain three parts:

1. Exit access - The section of the road leading to an exit. OSHA mandates that exits be at least 28 inches wide at all times.
2. Exit - The exit is usually separated from other areas to provide a safe path to the exit discharge.
3. Exit discharge - Directly outside or to a street, walkway, refuge area, public way, or open space with outside access.

OSHA highly advises that all organizations with more than ten workers prepare a documented Emergency Action Plan (EAP) to describe the processes and actions that employees will need in the event of a disaster or crisis.

And requires that at least two emergency exits be provided. However, depending on the number of employees and the size of the facility, more may be necessary.(Vectorsolutions, EHS Management, 2013)

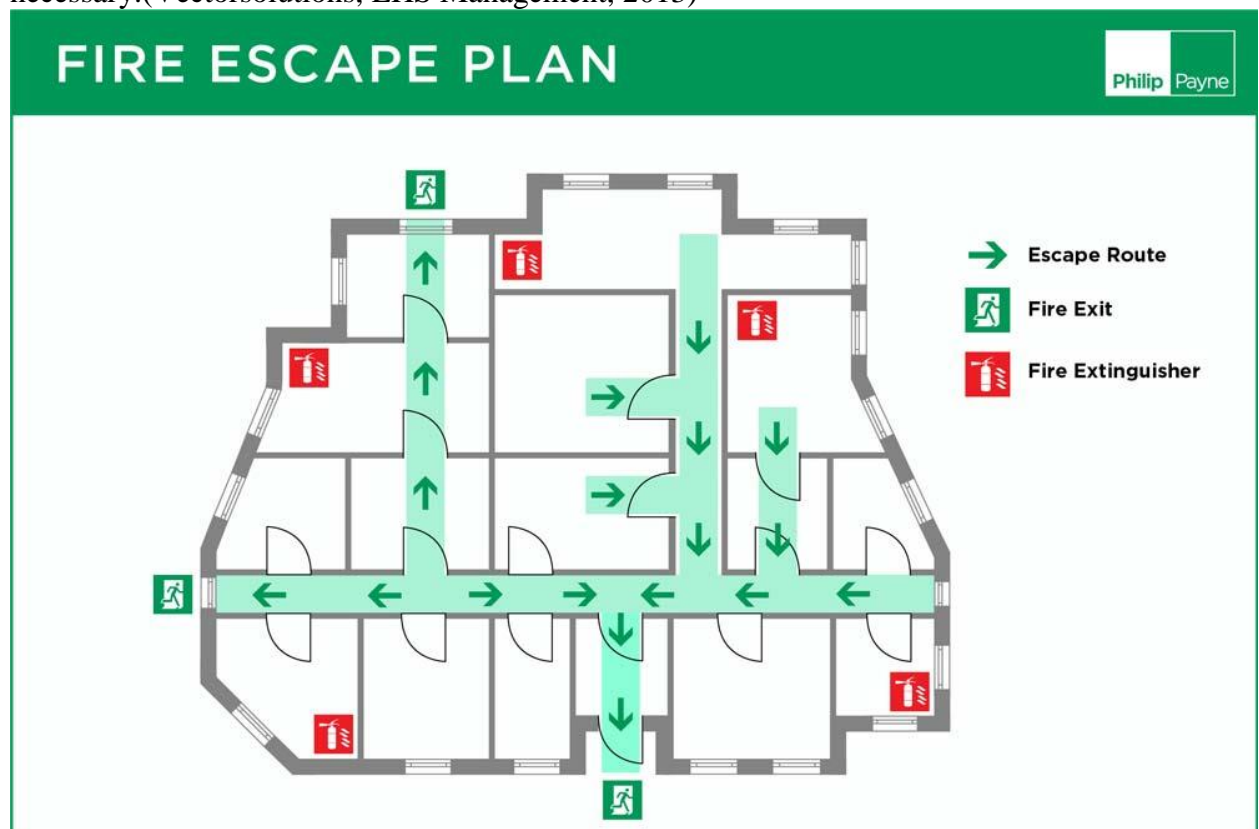

Figure3.19 (emergency escape route) (Philip Payne,2021)

This figure shows in the case of an emergency or power outage, a emergency escape route is a road that leads to a point of safety, such as a fire exit or covered stairs.

3.3.5. Insulation system:

As this project required a lot of glass facades and walls, Insulation should be taken into consideration in terms of heat and acoustics.

Insulating glass comes in a variety of kinds depending on the application, insulation requirement, or end user demand. The quantity of glass panes used in unit manufacturing, cavity-filling material, coatings, sealing material, and other aspects all contribute to design adaptability.

Glass insulation for structural glazing

Ordinary glass is a hazardous material option for outdoor applications since it cannot withstand predicted wind pressures and harsh weather conditions. As a result of their greater strength, insulating glass units are the most used glass type for residential, commercial, and industrial structural glazing. Multiple layers of glass increase the design element's strength, making it more sturdy, tough, and secure.

The versatility of insulating glass to different seasons makes it an excellent choice for windows and doors. The primary purpose of insulating glass was to insulate glazed areas from excessive heat loss or gain. During the summer, this glass prevents the heat of the sun from entering the inside. It keeps interior heat from escaping outside during the cold.

Insulating glass is, in fact, an ecofriendly glazing solution. Thermal insulation relieves the demand on heating and cooling equipment. It also makes it much easier to maintain a desirable interior temperature while consuming little electricity and energy. And this is significant when it comes to lowering heating and cooling costs as well as the carbon impact.

Insulating glass offers the extra benefit of reducing condensation difficulties as compared to standard single glass.

However, from a design standpoint, insulating glass provides a diverse variety of options for both big and small structural glazing projects. It may be utilized to create aesthetically appealing all-glass façades or captivating architectural façades by employing profiles that are only visible from the inside.

Insulating glass, on the other hand, acts as an excellent sound barrier. It features a good sound control feature.

The ideal acoustic performance of sound control glass is accomplished without compromising daylight by mixing various thicknesses of glass with a PVB interlayer within the double-glazed unit. When even more sound control is needed, increasing the gap between the glass panes can assist. (Peter Nischwitz, 2020)

As previously said, this project is fire risk, so the glass has to be fire resistant.

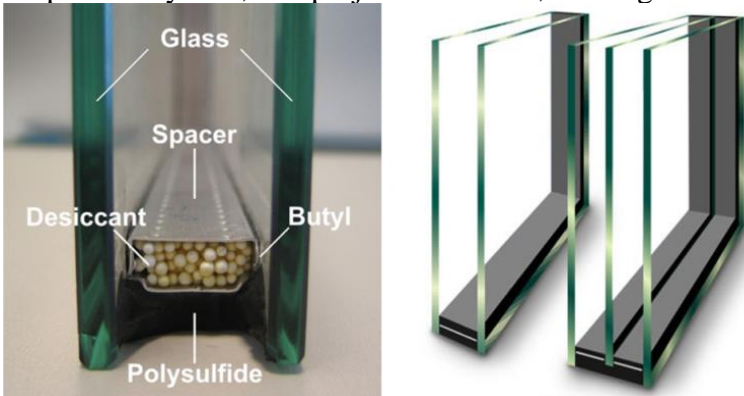

Figure3.20 (insulating glass) (Peter Nischwitz, 2020)

This photo shows the components of the insulating glass.

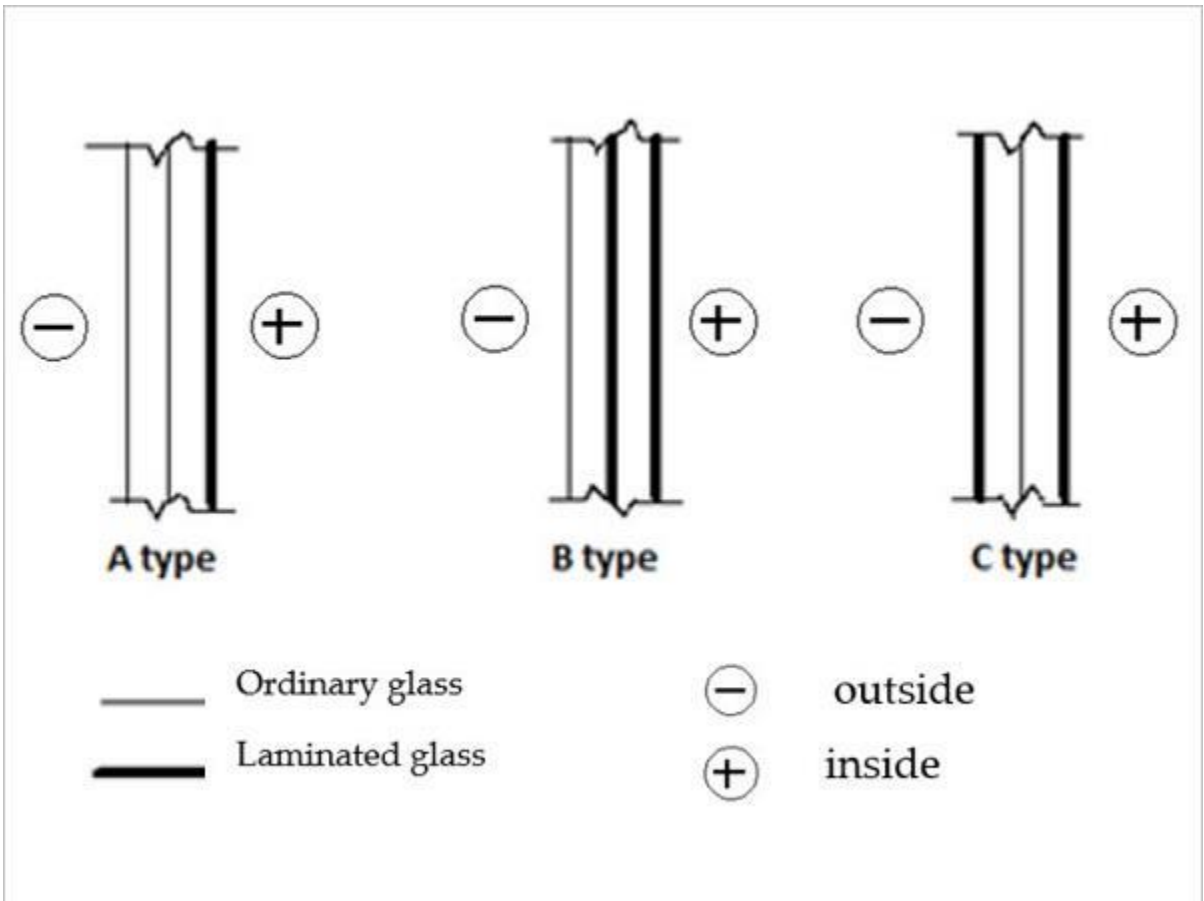

Figure3.21 (Glassonweb)(Buhagiar, 2022)

This photo shows the types of the insulating glass.

3.3.6. Electricity distribution system:

Because this building is based on technology and computer work, each workstation should have at least three power sockets for chargers and other items.

3.3.7. Lightening:

As previously said, natural lighting will be the primary source of illumination, however for added comfort, glass facades should not be placed behind screens.

For lighting, cold or neutral color temperatures (between 3000 K and 4000 K) are commonly considered ideal for office areas.

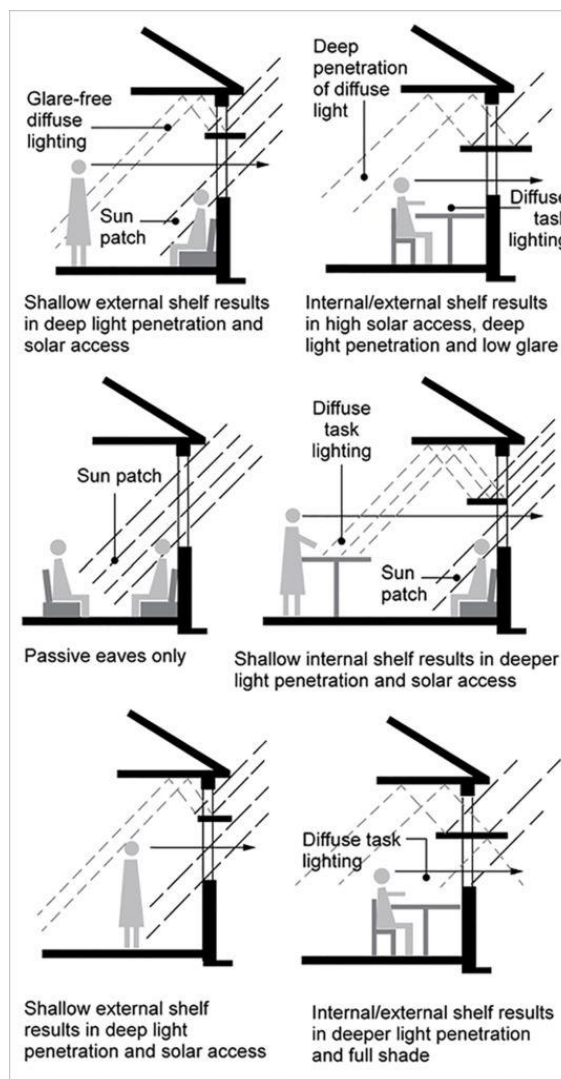

Figure3.22 (Natural light) (Engineering discovery,2020)

This figure shows how to deal with the sun rays.

3.3.8. Ventilation system:

Heating, ventilation, and air-conditioning (HVAC) are the "engines" that power most structures' comfort systems. They directly use the majority of the energy in buildings, making them significant from an environmental aspect. Furthermore, excellent indoor air quality is heavily dependent on the ventilation they offer, but a faulty mechanical system can develop and transport interior contaminants.

The first place to look to reduce the impact of a mechanical system is not the equipment, but the building's design and construction. Careful, integrated design and optimal levels of insulation can reduce the need for supplemental heating, ventilation, or air conditioning. In cases where a central mechanical system is still required, an efficient building envelope can help to reduce the size of that system.

3.3.9. Strategies for building design and HVAC systems:

A well-designed structure may also considerably minimize distribution needs and offer enormous potential savings in both initial and running expenditures. Buildings with extremely well-insulated walls and high-performance windows, for example, may no longer require outdoor heat distribution to ensure comfort. Shortening duct lines to the nearest location in each room saves money and space while reducing the possibility of excessive air leakage from the duct system (which should be sealed with duct mastic, not duct tape, at all joints).

After decreasing the loads that a mechanical system must meet, it is critical to properly size the system to meet the remaining loads. Because heating and cooling equipment is most effective when functioning at full capacity, an oversized system initially loses money and materials and then functions inefficiently.

Mechanical equipment should be as efficient as feasible, long-lasting, and designed for simplicity of maintenance. Fresh air should be delivered to each inhabited space and diffused to minimize pockets of trapped, stale air, as is usual practice with heating and cooling. (Thidaco, 2020)

3.3.10. Mixed-mode system:

The concept of "mixed-mode" refers to a hybrid technique to space conditioning that combines natural ventilation through moveable windows (either manually or automatically controlled) with mechanical systems for cooling that include air distribution and refrigeration equipment. A well-designed mixed-mode building starts with smart facade design to reduce cooling demands. It therefore combines the use of air cooling when and where it is essential with the use of natural ventilation wherever possible or appropriate to enhance comfort while avoiding the high energy consumption and running expenses of year-round air conditioning.

The air conditioning and the moveable windows operate together. There does not appear to be a "standard" mixed-mode method in use today; each building remains unique. However, there are other classification methods that define the integration of natural ventilation and air-conditioning management strategies, often based on whether they exist in the same place or function at the same time.

3.3.11. Cleaning system:

The Façade Access division specializes in the design and construction of suspended and fixed access systems that allow high-level maintenance tasks to be carried out safely and effectively.

The system designers are able to develop Façade Access solutions that merge perfectly with the building's architecture by planning from the beginning.

There are two types of facade access equipment:

- Permanent access systems

Permanent access systems are categorized as either:

1. Suspended, such as building maintenance units.
2. Fixed, such as traveling gantries.

-personal suspension systems

Tracks and anchorages designed for use with rope access techniques are included in personal suspension systems. (Rostek-UK, 2018)



Figure 3.23(personal suspension systems) (vertiqualsafety)

This figure shows one of the ways that they use for cleaning high glass facades, with taking safety into consideration.

3.4. Project areas' Program:

Administration:

Space	Area/msq	Users	#Users	Activities	Equipment	Notes
-Reception	30	-Employees -Cleaners -Maintenance workers	4	-Working -Welcoming	-Reception counter, Small waiting area includes seats.	No clients in this department
-Security room	20	-Security	4	-Working	-Desks, monitoring screens	
-Secretary office	40	-Employees -Cleaners -Maintenance workers	2	-Working	-Desks and seats	
-General director room	50	-Director -Cleaners -Maintenance workers	1	-Working	-Desks and seats	
-Meeting rooms	60	-Employees -Cleaners -Maintenance workers	26	-Meetings	-Meeting table and seats	
-Shared offices	60	-Employees -Cleaners -Maintenance workers	15	-Working -Share ideas	-Shared desks	Accountant, Marketing, HR, Public relations.

Total area: 260 msq

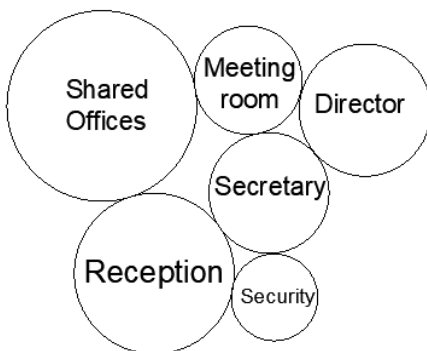

Hardware department:

Space	Area/msq	Users	#Users	Activities	Equipment	Notes
-Reception, lobby and waiting area	100	-Employees -Costumers -Maintenance workers -Cleaners	150	-Working -Welcoming	-Reception counter, Waiting area includes seats.	
-Security room	40	-Security	4	-Working	-Desks, monitoring screens	
-Secretary office	20	-Employees -Cleaners -Maintenance workers	2	-Working	-Desks and seats	
-Hardware director room	20	-Director -Cleaners -Maintenance workers	1	-Working	-Desks and seats	
-Meeting rooms	40	-Employees -Cleaners -Maintenance workers	26	-Meetings	-Meeting table and seats	
-The Exhibition	200	-Costumers -Employees -Maintenance workers -Cleaners	100 per day	-Display products	-Tables -Screens -Products	
-Cashier	20	-Costumers -Employees -Maintenance workers -Cleaners	100 per day	-Buying and paying for products	-Cashier counter -Seats	
-Maintenance sector	100	-Employees -Maintenance workers -Cleaners	15	-Maintenance products	-Maintenance equipment	
-Store	70	-Employees -Workers	4	-Storing items	-Cupboards	

Total area: 610 msq

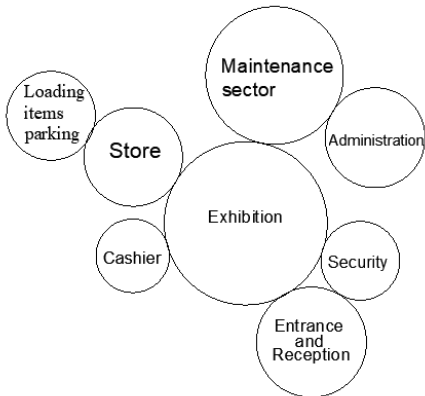

Training Center:

Space	Area/msq	Users	#Users	Activities	Equipment	Notes
-Reception, lobby and waiting area	200	-Employees -Costumers -Maintenance workers -Cleaners	200	-Working -Welcoming	-Reception counter, Waiting area includes seats.	
-Security room	40	-Security	4	-Working	-Desks, monitoring screens	
-Secretary office	40	-Employees -Cleaners -Maintenance workers	2	-Working	-Desks and seats	
-Instructors' room	60	-Instructors -Cleaners -Maintenance workers	10	-Working -Resting	-Desks and seats	
-Meeting room	60	-Employees -Cleaners -Maintenance workers	15	-Meetings	-Meeting table and seats	
-Computer labs	80 per lab	-Employees -Cleaners -Maintenance workers	20	-Courses	-Desks and seats -Computers -Instructor's Table -Whiteboard -Projector	5 labs needed
-Halls	200 per lab	-Employees -Cleaners -Maintenance workers	100	-Courses	-Seats -Whiteboard -Projector	5 Halls needed

Total area: 1800 msq

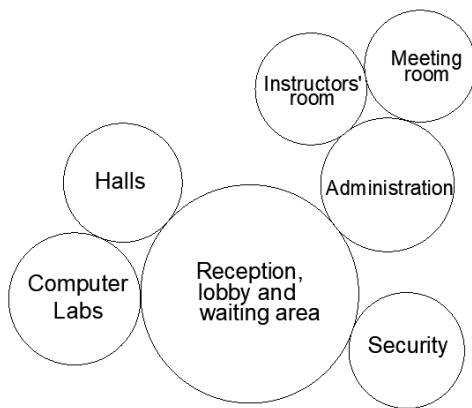

Software Department:

Space	Area/msq	Users	#Users	Activities	Equipment	Notes
-Reception, lobby and waiting area	160	-Employees -Cleaners -Maintenance workers	200	-Working	-Reception counter, Waiting area includes seats.	No clients in this department
-Security room	30	-Security	20	-Working	-Desks, monitoring screens -Cupboards	Security guards are scattered across the department.
-Secretary office	40	-Employees -Cleaners -Maintenance workers	5	-Working	-Desks and seats -Cupboards	
-Director office	50	-Director -Cleaners -Maintenance workers	1	-Working	-Desks and seats -Cupboards	
-Private offices	20 per office	-Team leaders -Cleaners -Maintenance workers	3 per office	-Working	-Desks and seats -Cupboards	50 private offices
-Shared offices	80 per workplace	-Employees -Cleaners -Maintenance workers	150	-Team working	-Desks and seats -Cupboards -Tables	-Every 10 employees in a workplace -15 Workplaces needed
-Meeting rooms	40 per room	-Employees -Cleaners -Maintenance workers	10	-Meetings	-Meeting table and seats -Whiteboard	-15 rooms needed
-Conference hall	50 per room	-Employees -Cleaners -Maintenance workers	20	-Meetings -Online Meetings	-Meeting table and seats -Screen and projector -Acoustic system	-10 rooms needed
-Archive rooms	80 per room	-Employees	15			-5 rooms needed
-Servers floor	500	-Employees -Security	20			

Total area: 4480 msq

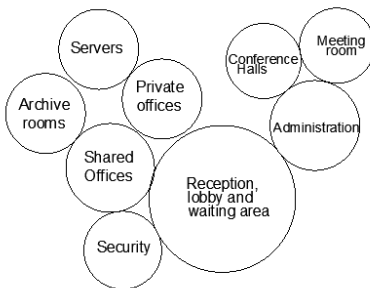

Cafeteria:

Space	Area/msq	Users	#Users	Activities	Equipment	Notes
-Eating Hall	300	-Employees -Trainers -Maintenance workers -Cleaners	450	-Eating -Break time	-Chairs -Tables -Big trash -Plates' return counter -Food counter	
-Kitchen	80	-Employees -Cleaners -Maintenance workers	10	-Cooking -Cleaning	-Cupboards -Fridges -Kitchen equipment	
-Storage	60	-Employees -Cleaners -Maintenance workers	5	-Storing	-Cupboards -Fridges	

Total area: 440 msq

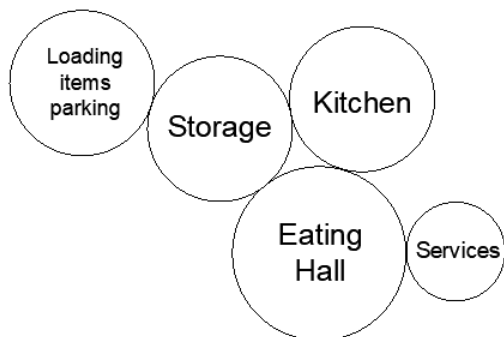

Shared Places:

Space	Area/msq	Users	#Users	Activities	Equipment	Notes
-Multipurpose room	120	-Employees -Trainers	450/ 50 per room	-Break time	-Play station -Board games -Tables and chairs	-3 multipurpose rooms needed
-Music room	60	-Employees -Trainers	10	-Break time	-Musical instruments -Acoustics system	-5 needed
-Creative sitting areas	500	-Employees -Trainers	450/ 50 per room	-Break time	-Tables and chairs -Whiteboard -Couches -Plants	-5 needed
-Outside green areas	850	-Employees -Trainers		-Break time	-Sitting areas -Plants	-7 needed

Total area: 9110 msq

Services:

Space	Area/msq	Users	#Users	Activities	Equipment	Notes
-WCs	1000	-Employees -Trainers -Maintenance workers -Cleaners -Exhibition Visitors	500			
-Kitchenette	100	-Employees -Maintenance workers -Cleaners	2	-Services	-Kitchen equipment	
-Storage	200	-Maintenance workers -Cleaners	2	-Storing	-Cleaning equipment	
-Mechanical and electrical room	200	-Maintenance workers	2	-Maintenance		

Total area: 1500 msq

Total project area= 12000 msq/ 12 Donum

Minimum required land area = 8000-10000 msq/ 8-10 Donum

Bubble Diagram:

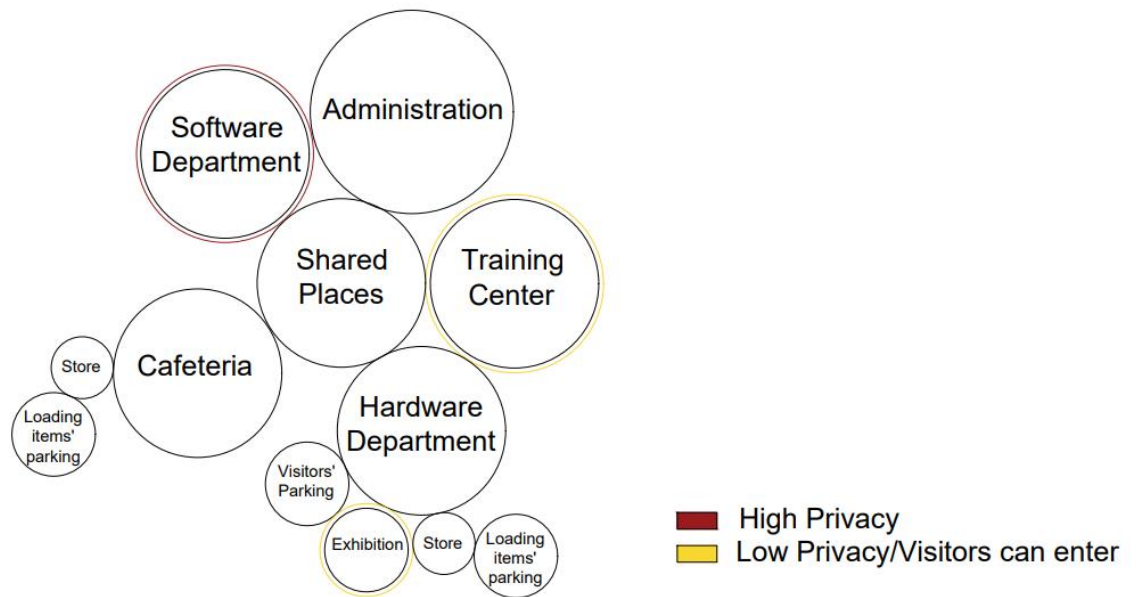

This bubble diagram shows the relation between the spaces.

Adjacency Matrix:

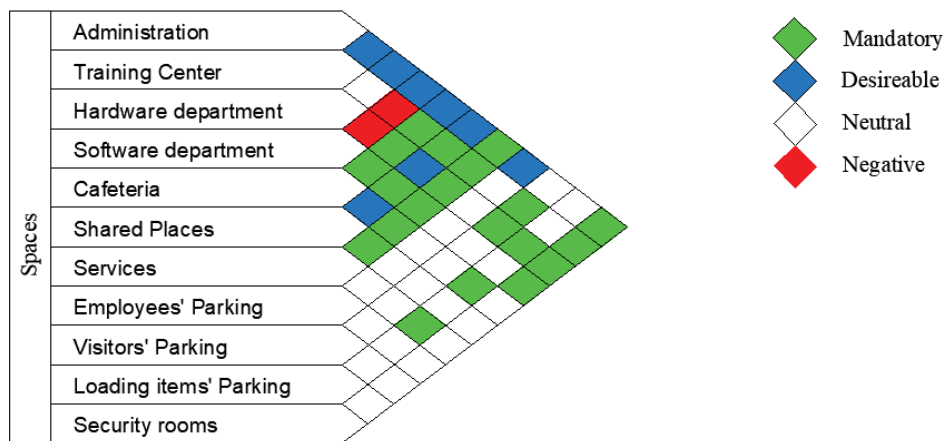

This adjacency matrix shows the relation between the spaces.

Chapter Four

Site Analysis

4.1 Location

4.1.1. Regional location



Figure4.1 (Regional location)(Googlemaps)

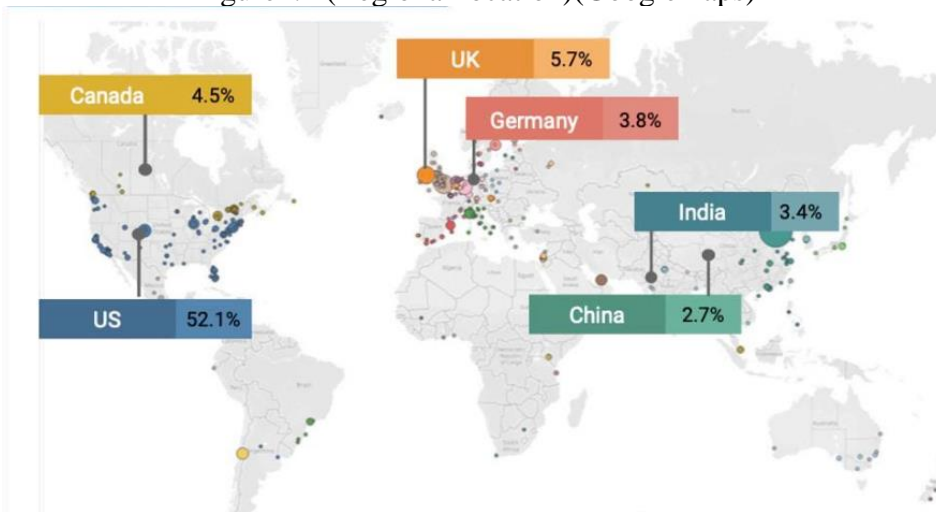

Figure4.2 (Company Distrebuton)(Andrea Murphy,2018)

As I previously stated and since this graph emphasizes, the West Bank is lacking in technological firms. As a result, the location of my project will be chosen in the West Bank, specifically in Palestine, as it is the most in need of economic emancipation and worldwide emerging.

4.1.2. City Selection:



Figure4.3 (Site location)(Googlemaps)

Choosing Nablus as the city for the site location was due to several reasons:

It is approximately in the middle of the West Bank, It is accessible, and recently Nablus is one of the most populous Palestinian cities and the most significant site. It is home to Palestine's largest university. Nablus is regarded the northern West Bank's core, as well as Palestine's economic capital. It was the largest economic and industrial center in Palestine before to the Nakba and the West Bank afterward.

The most attractive geographical point in the heart of Palestine, highlighted by its strategic location that connects its north and south, east and west. The governorate covers around 605 square kilometers, whereas the city covers only 29 square kilometers.

The city saw urban growth that stretched from east to west and encompassed a number of neighboring communities.

The city's urbanization spreads across Mount Ebal to the north and Mount Gerizim to the south, with a valley stretching to the west between them.

4.1.3. Site Location:



Figure4.4 (Site location)(Googlemaps,2022)

This photo shows the site is located in 25 street-Nablus/Palestine in the west side of the city, between An Najah University and Zawata roundabout.

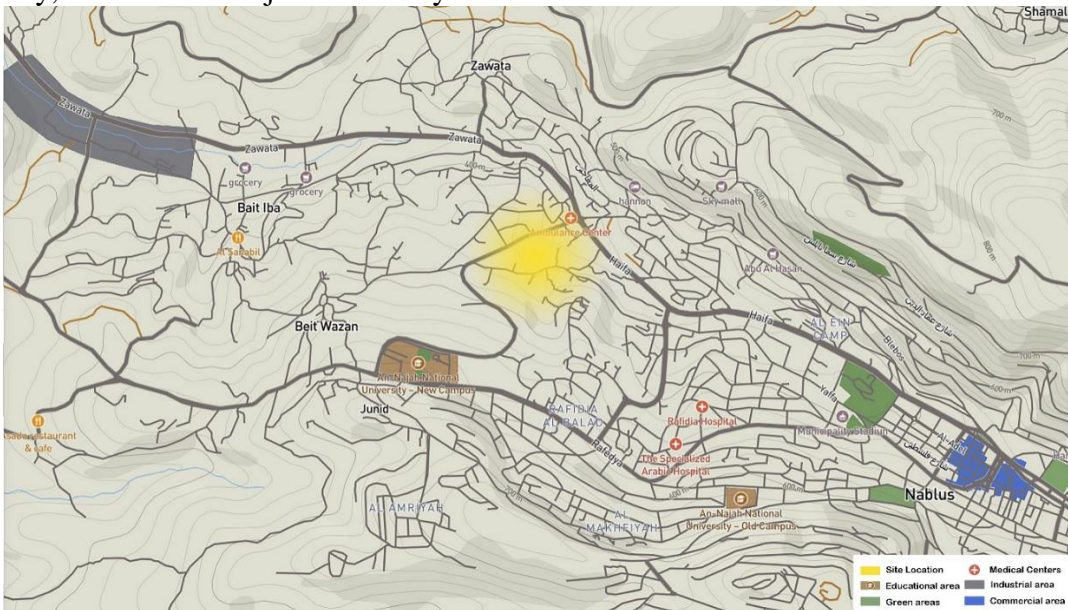

Figure4.5(Site surrounding)(mapsbox,2022)

This figure explain the site's surroundings.

Due to the presence of a training center in the corporation and the fact that students are one of the primary customers, the University's closeness to the site promotes the site's qualities.

In the long-term, the corporation may expand and begin manufacturing, therefore the closeness of the industrial region benefits the site selection.

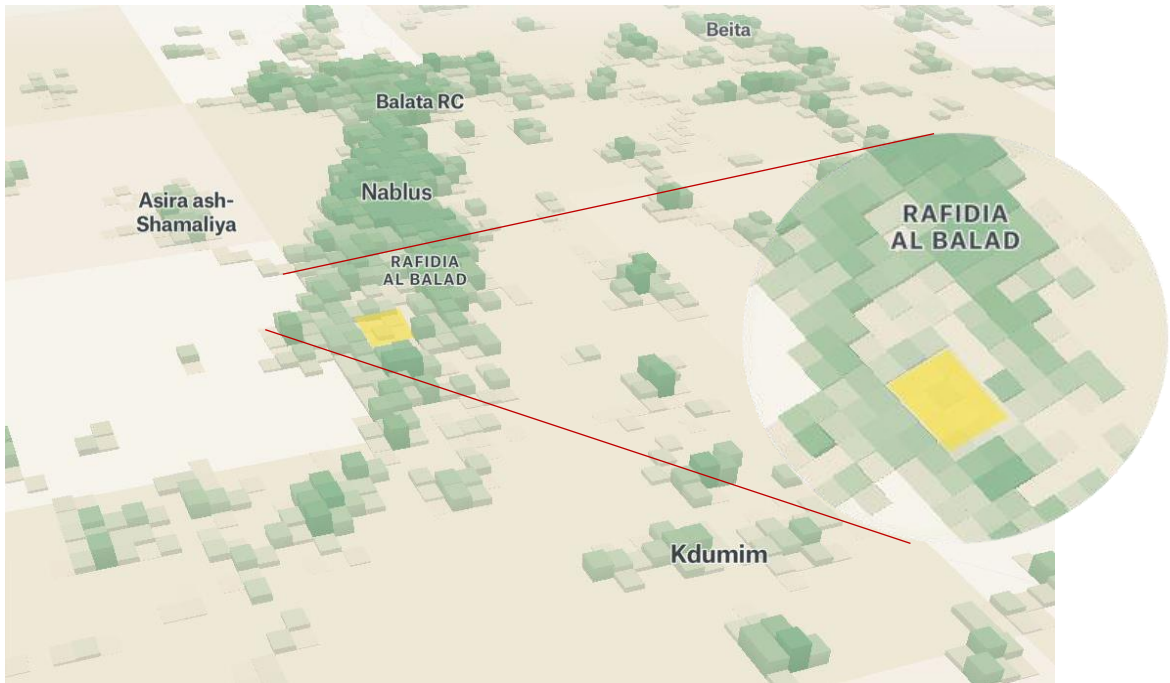

Figure 4.6 (Site Population)(The Pudding, 2022)

In this photo the yellow zone is the site and the green boxes shows the population ratio in the city and around the site.
 And we can see that the site location is not that crowded comparing to the surrounding.

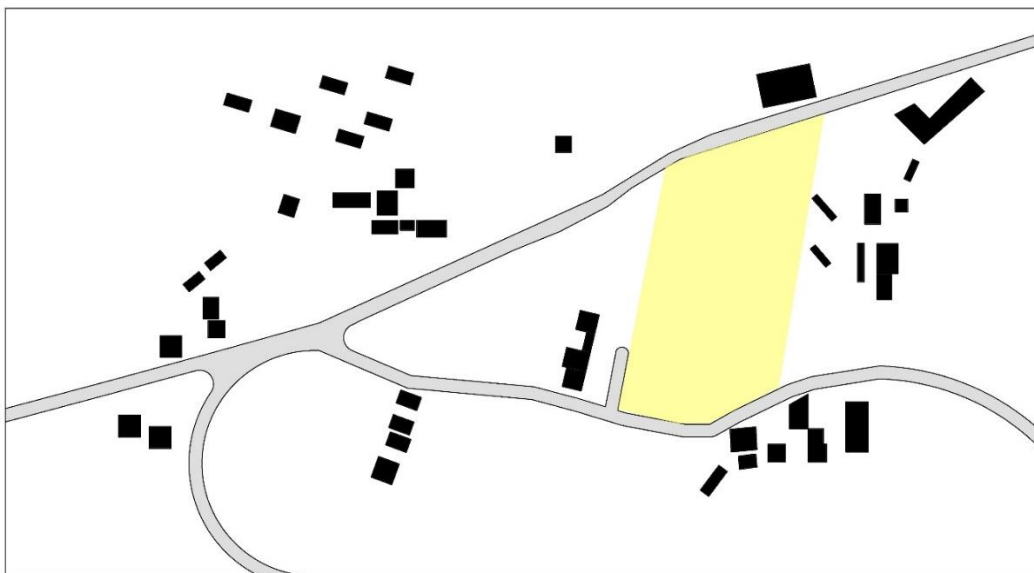

Figure 4.7 (Solid and void)(openmapstreet,2022)

And this plan shows the solid, and the roads that surrounds the location.

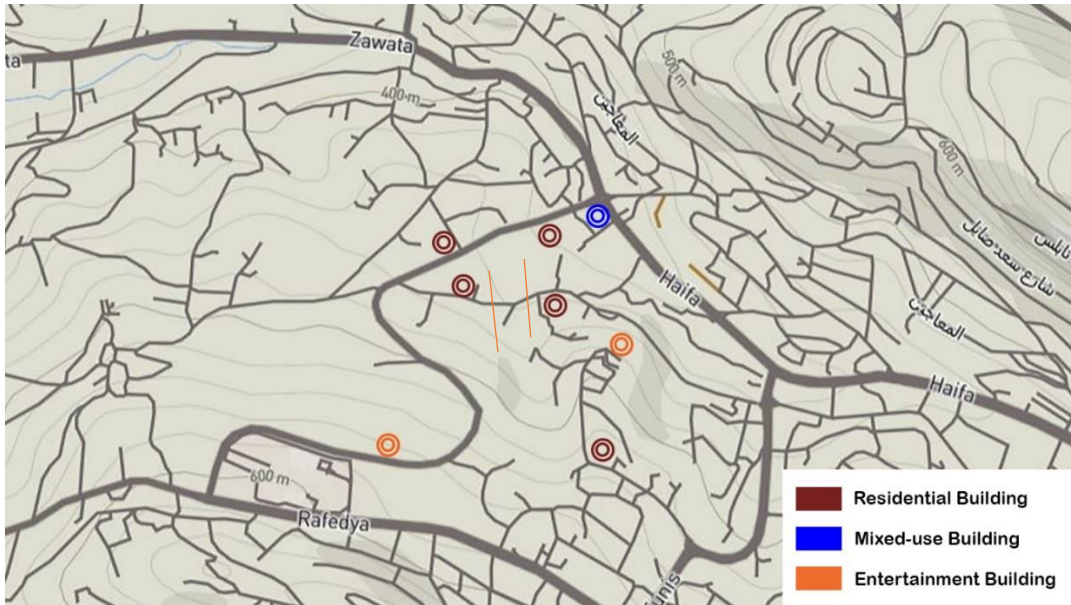

Figure 4.8 (Surrounding type buildings)(Googlemaps,2022)

This figure shows the surrounding type buildings, and how far from the site.

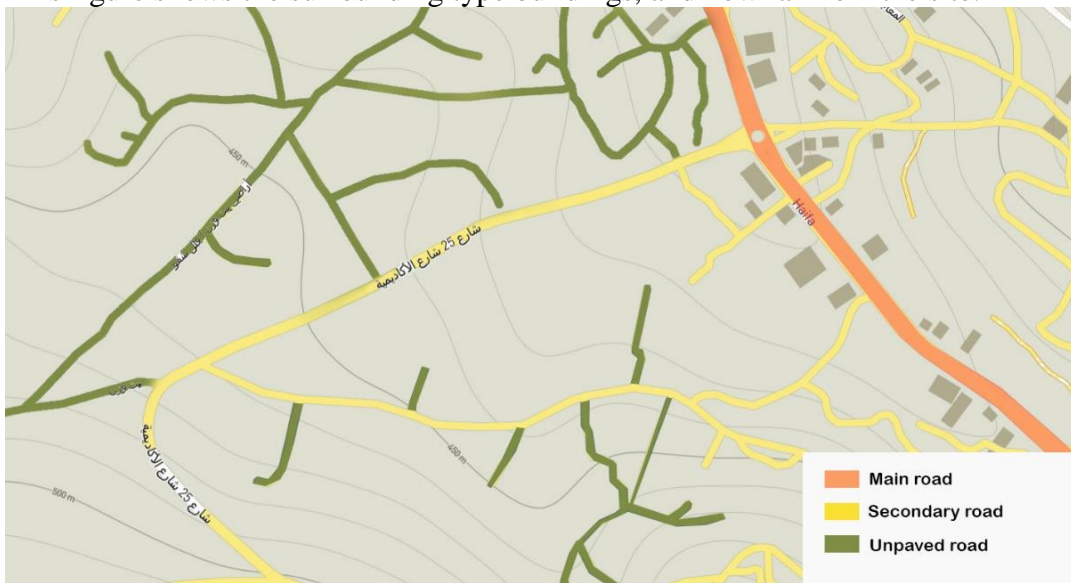

Figure4.9 (site's surrounding roadways)(Googlemaps,2022)

This diagram depicts the site's surrounding roadways.



Figure4.10 (site accessibility)(Googlemaps,2022)

This diagram shows Strategic location, easily accessible; it takes 3 minutes by public transportation from the university and 4 minutes by public transit and 7 minutes walking from the city center.

There is also public transit between villages and towns because it is close to the city's exit.

And it is surrounded by one primary two-sided street called 25 street, with a width of 12-15 meters, two minor roads with a width of 7 meters, and one secondary road that will be built in the near future.

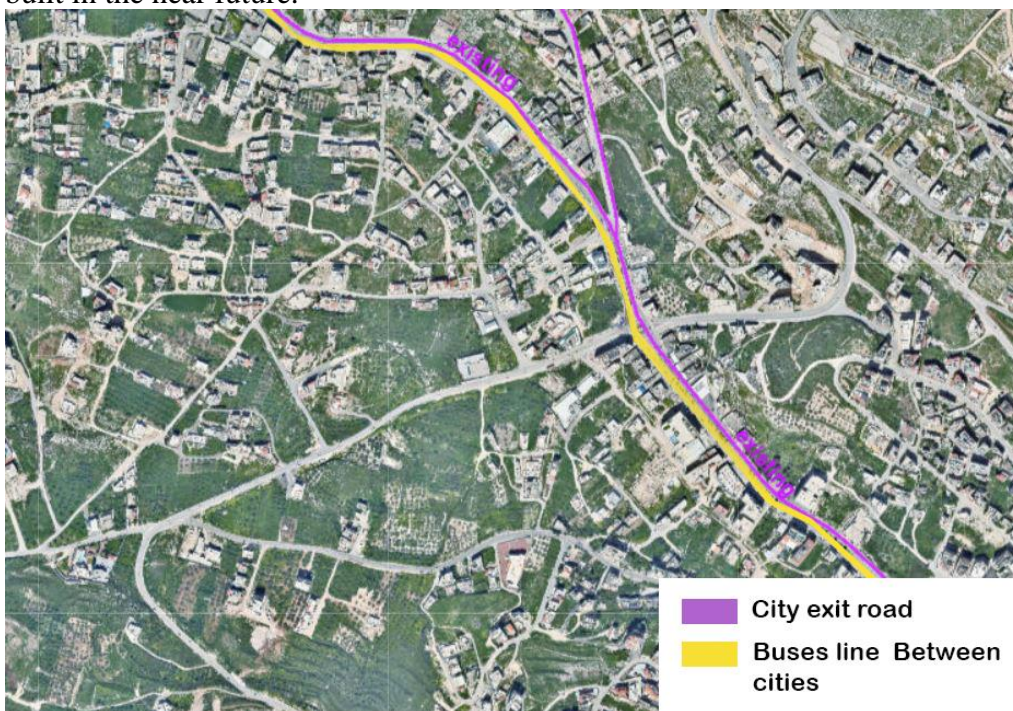

Figure4.11 (site accessibility)(Googlemaps,2022)

This figure shows the nearest city exit from the site.

4.2. Site Characteristics

4.2.1. Site Contour:

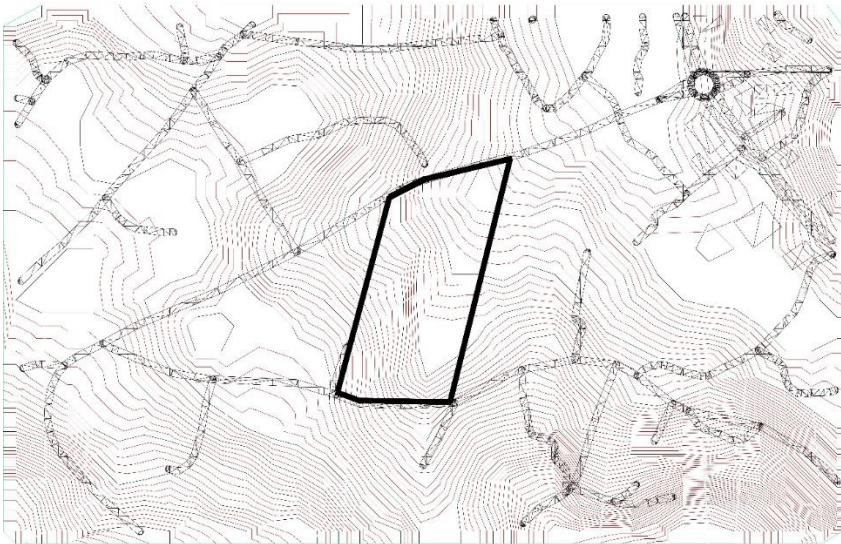

Figure4.12 (site contour)(Civil 3D,2022)

This figure shows the site's contour by 1 meter high.

4.2.2. Site environment:

Nablus has a good environment and a good climate as the research shows in this figures
Lat.: 32°13'N / Lon. 35°15'E / Altitude: 555.95 m.



Figure4.13 (City temperature) (Ventusky,2022)

This graph shows the average temperature of the city, which is moderate.



Figure4.14 (City humidity) (Ventusky,2022)

This figure shows the average humidity of the city, which is neither high nor low.

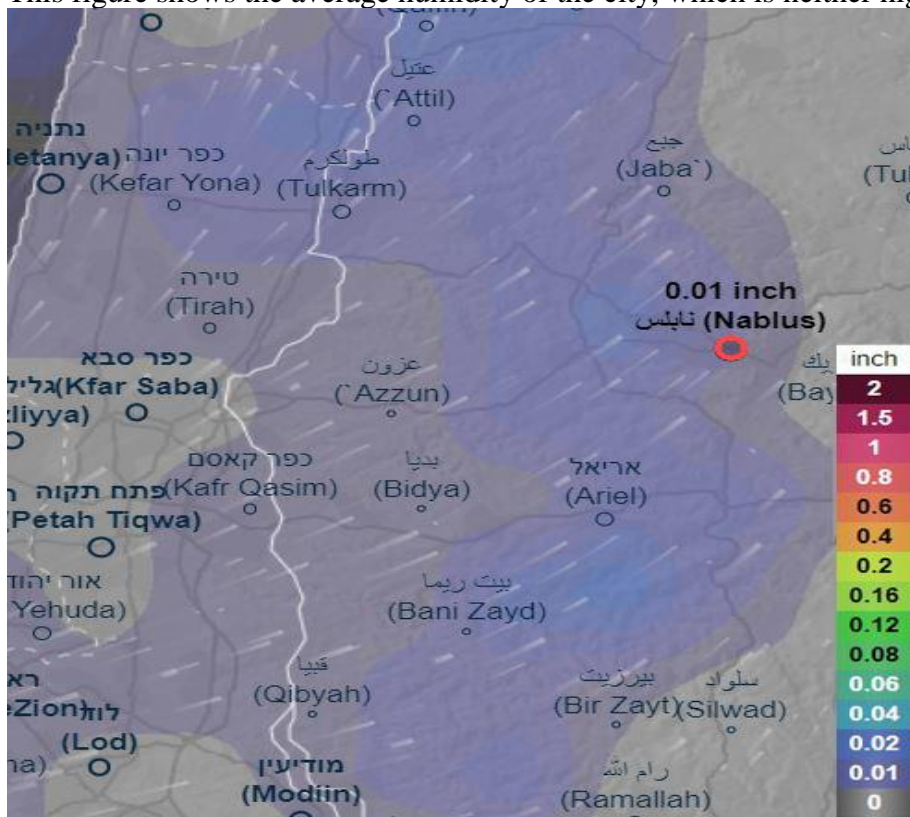

Figure4.15 (City precipitation rate) (Ventusky,2022)

This figure shows the precipitation rate which is low.

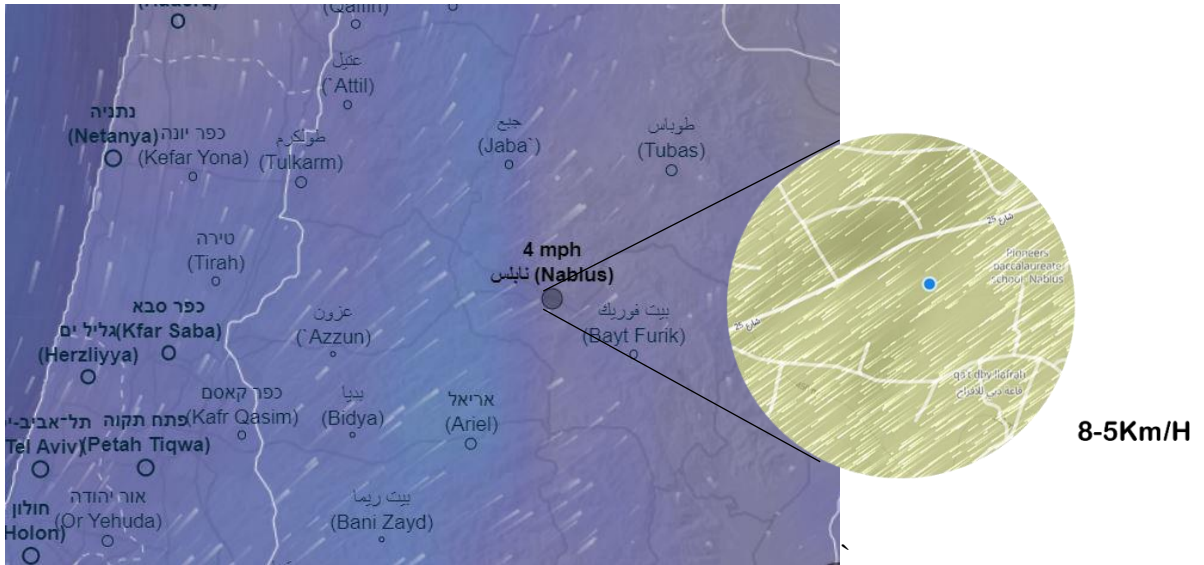

Figure4.16 (City wind speed) (Ventusky,2022)

This figure shows the wind speed that equals 5-8Km/h.

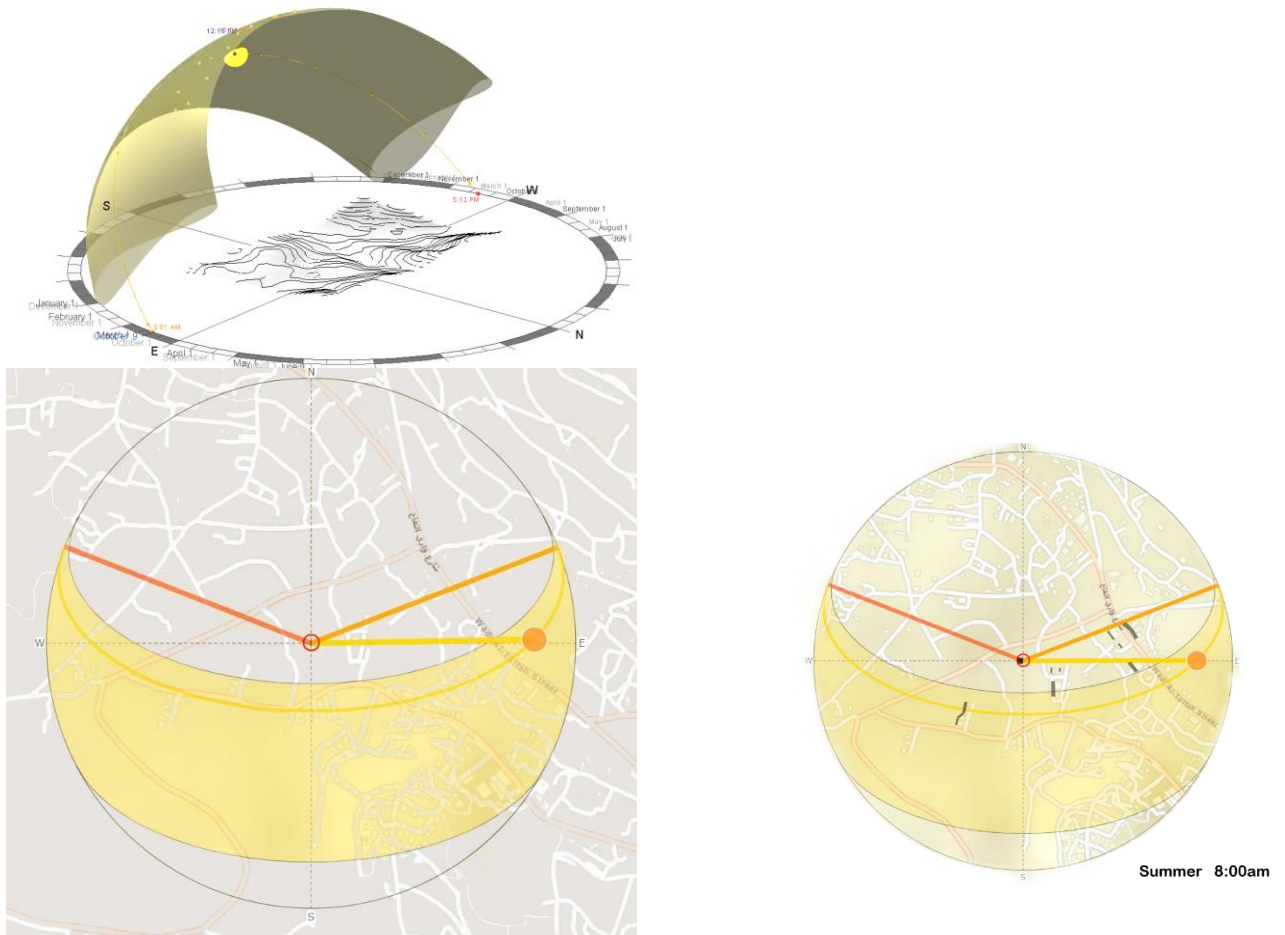
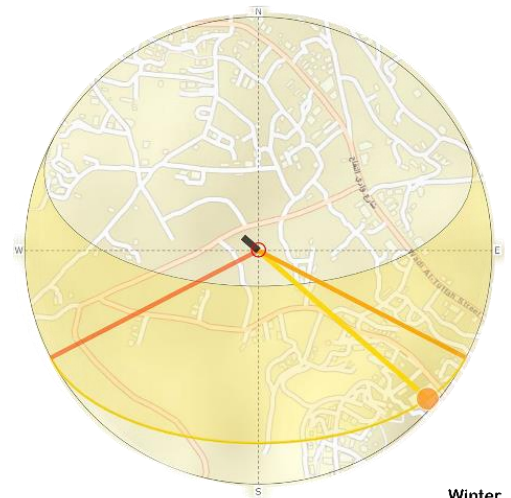
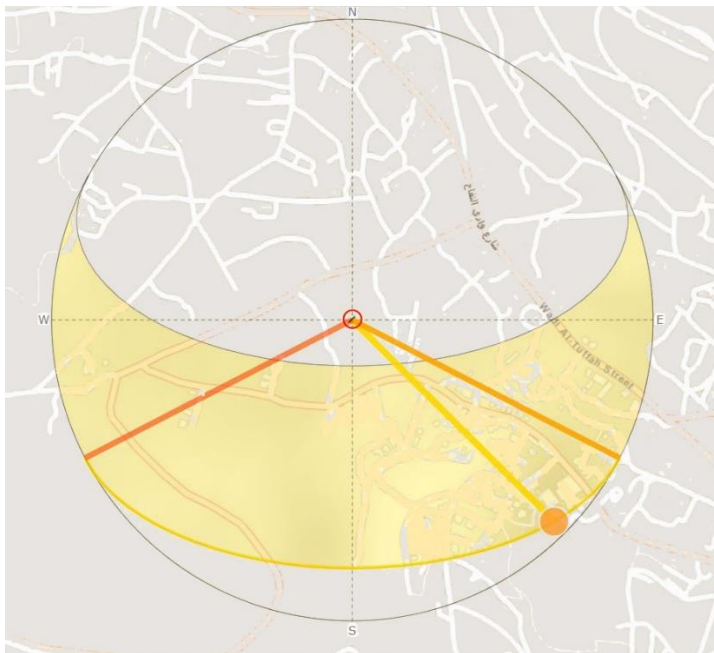
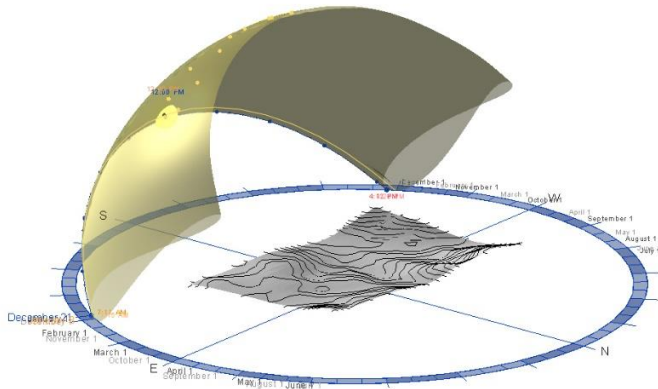

Figure4.17 (summer sun direction) (Suncal, 2022)

This figure shows the sun's effect on the site in the summer.



Winter 8:00am

Figure4.18 (winter sun direction) (Suncal, 2022)

This figure shows the sun effect on the site in the winter.



Figure4.19 (Stream Line) (Geomolg,2022)

Because the rainfall in Nablus is mild, there is an advantage to this location, which is the stream line as shown in this aerial photo.

4.2.3. Site Details:

The current location of the site is a field, which is undeveloped property.

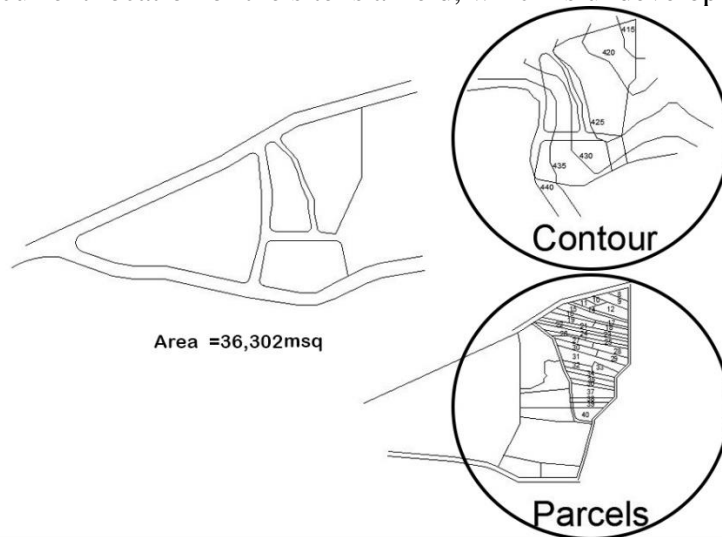

Figure4.20 (Parcels) (Geomolg,2022)

This figure explains these information:

Area= 13 msq

Parcels from 8-40

Contour every 5 meters from 415-440

Soil type: clay loam and clay

Geopolitical classification: A

There is no groundwater sensitivity
 Land of low agricultural value
 Classification: 'C' residential areas with special laws
 Slope 7%

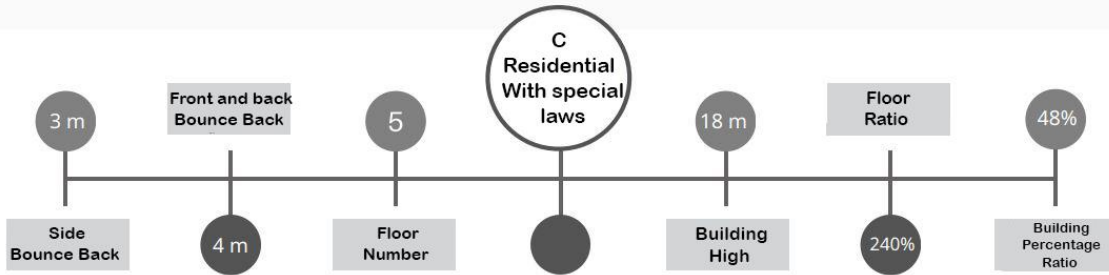

Figure4.21 (Classification) (Municipality,2022)

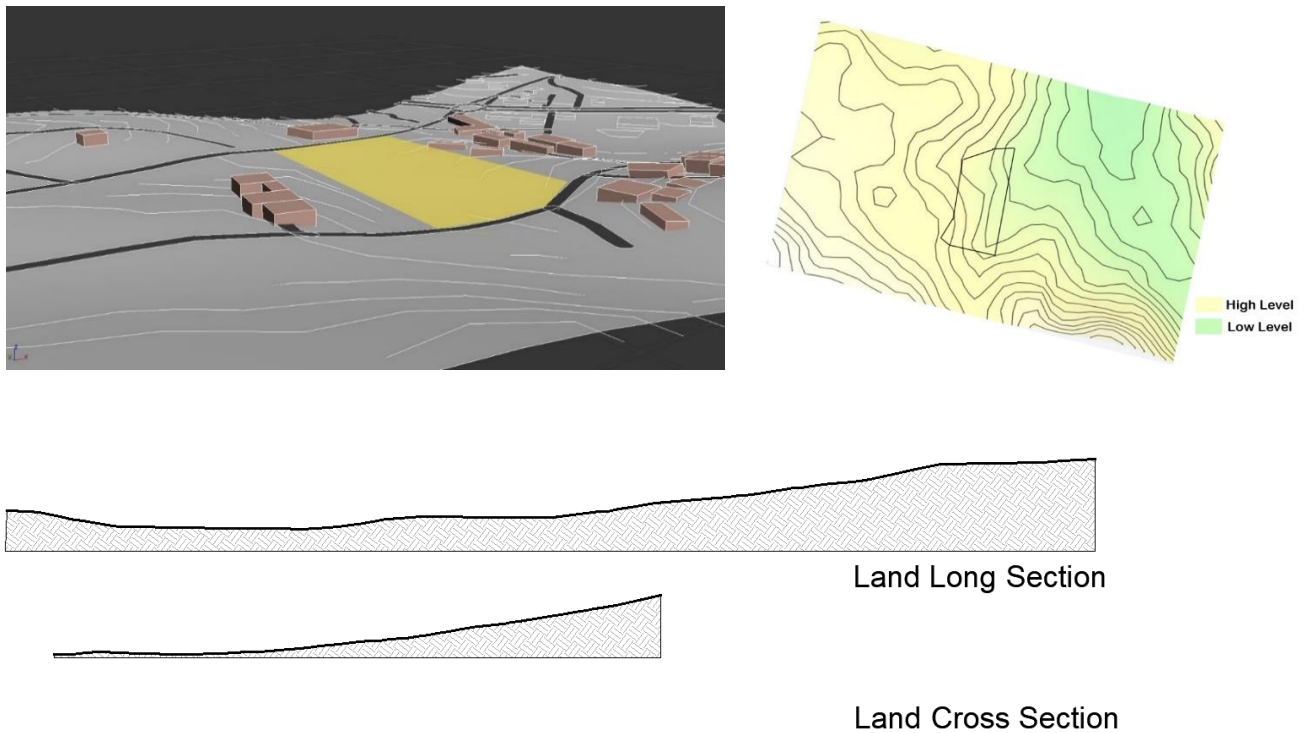

Figure4.22 (Site topography) (Mapcadder,2022)

This figure shows the site topography which is suitable for this types of buildings.
 This site modeling emphasizes topography and indicates the height of the surrounding buildings,
 which are one level high.

Chapter Five Design

5.1 2D Drawings

5.1.1. Site Plan

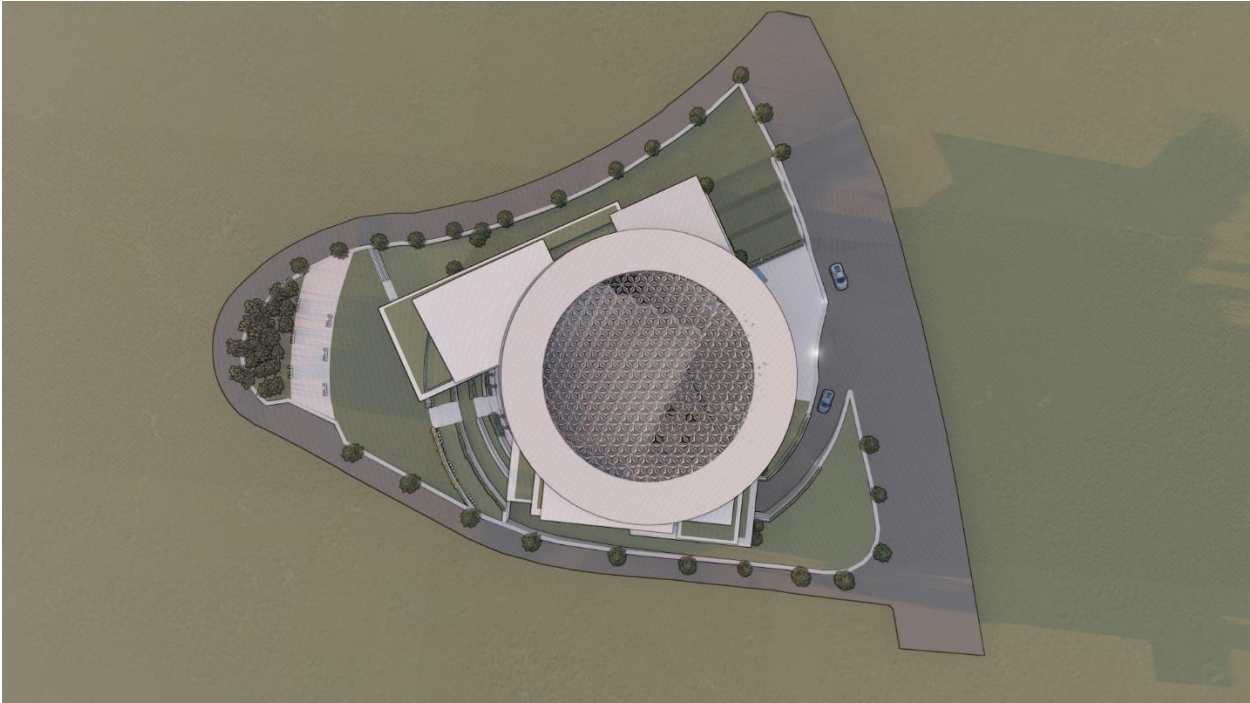

5.1.2. Basement floor

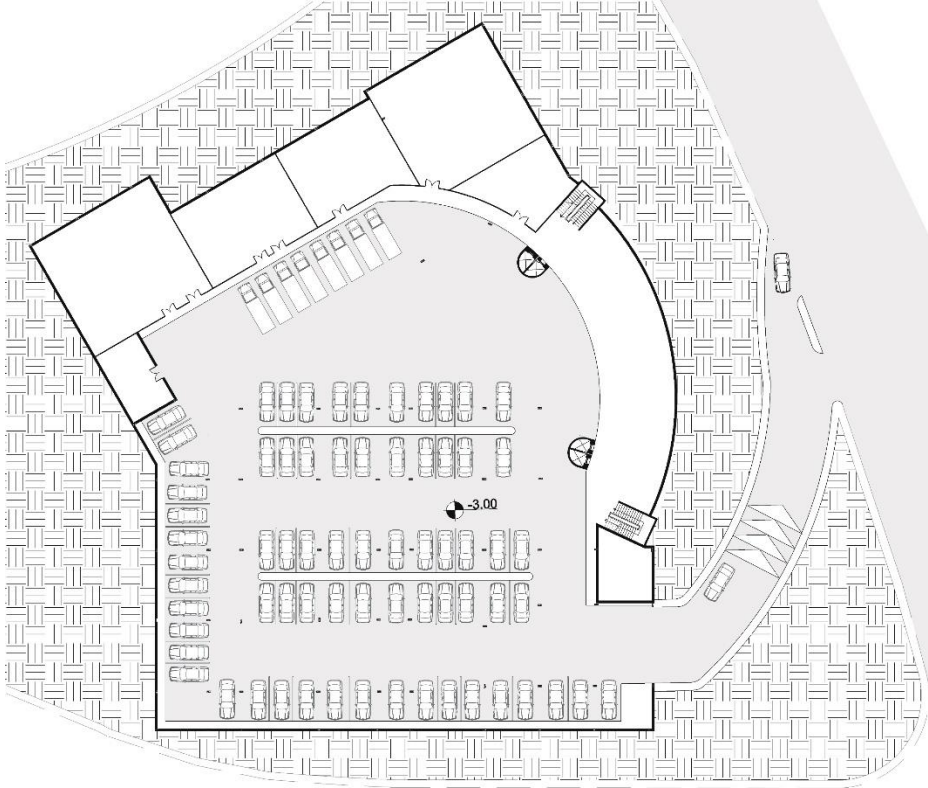

5.1.3. Ground floor

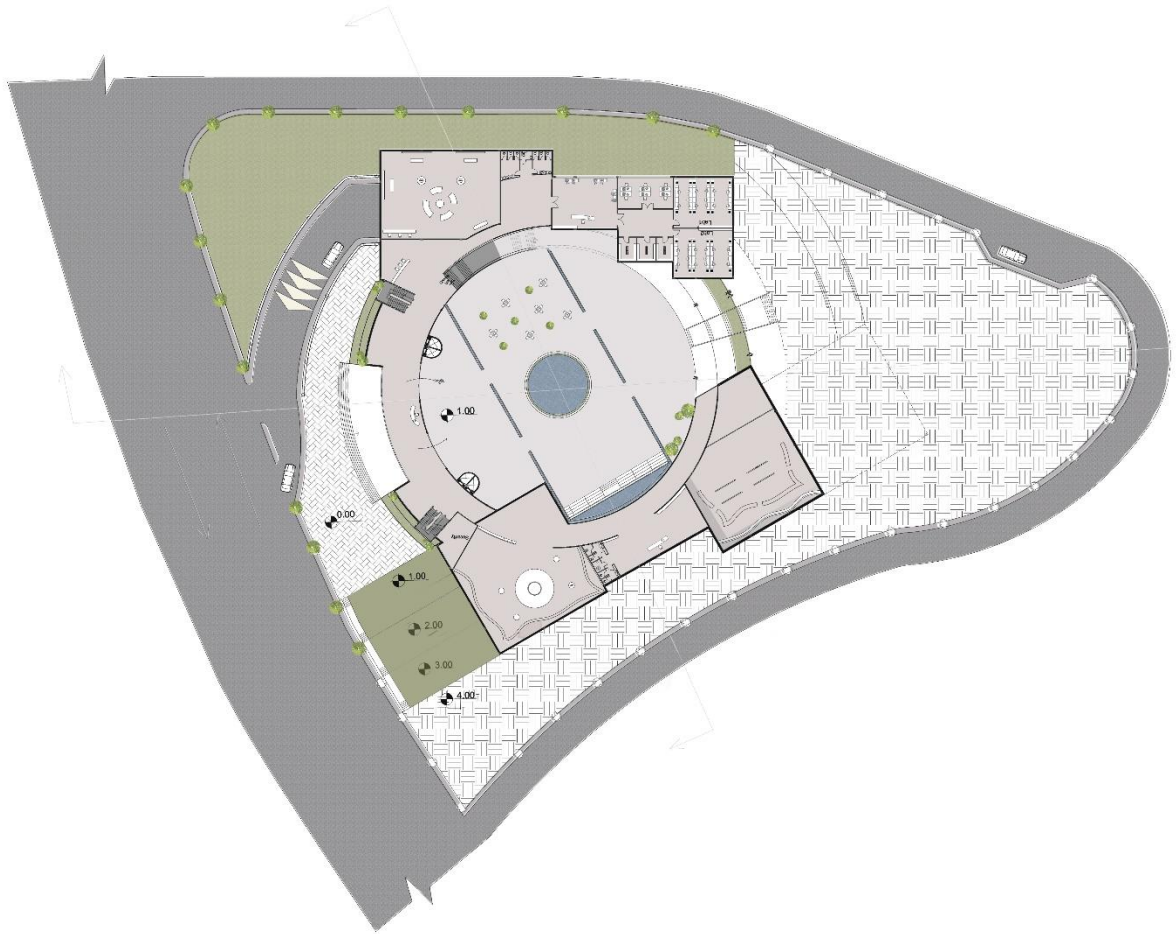

5.1.4. First floor

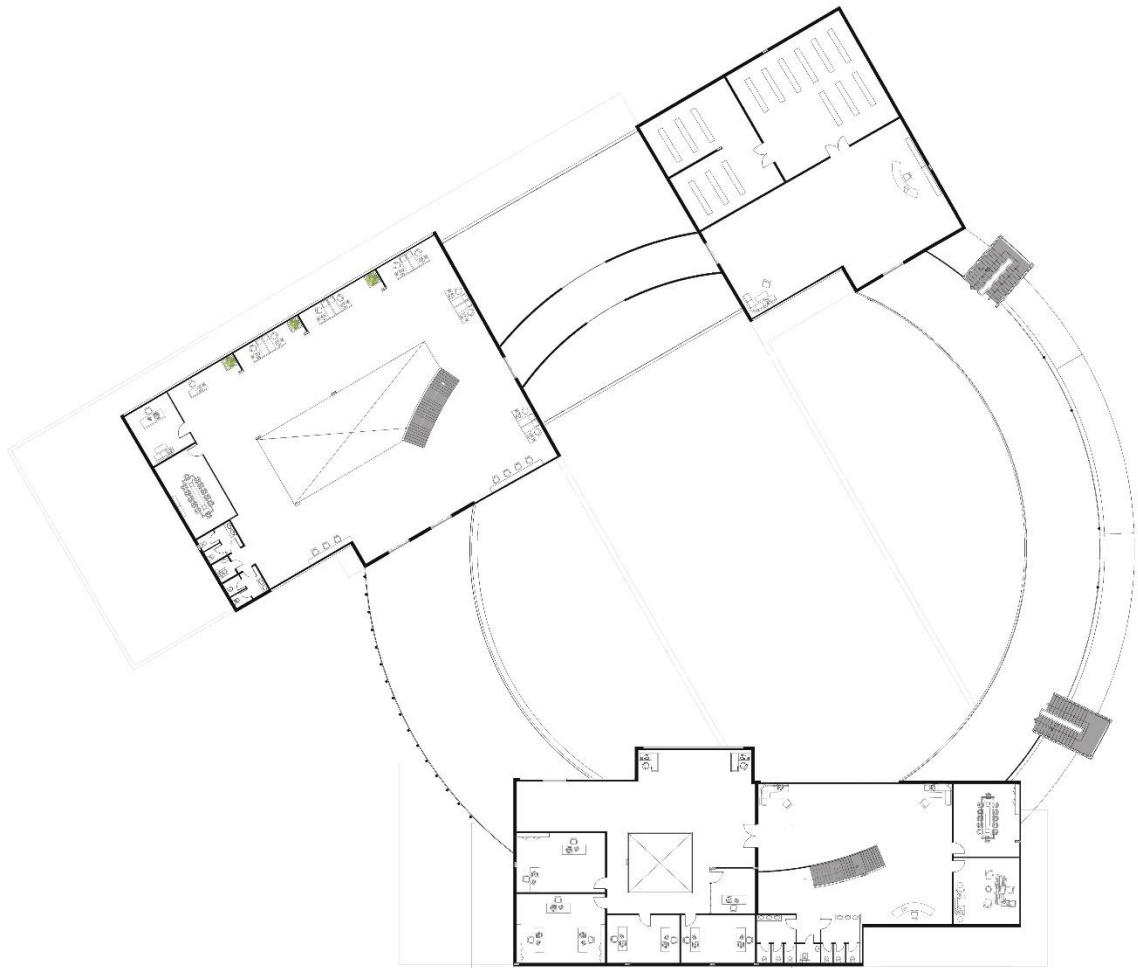

5.1.5. Second Floor

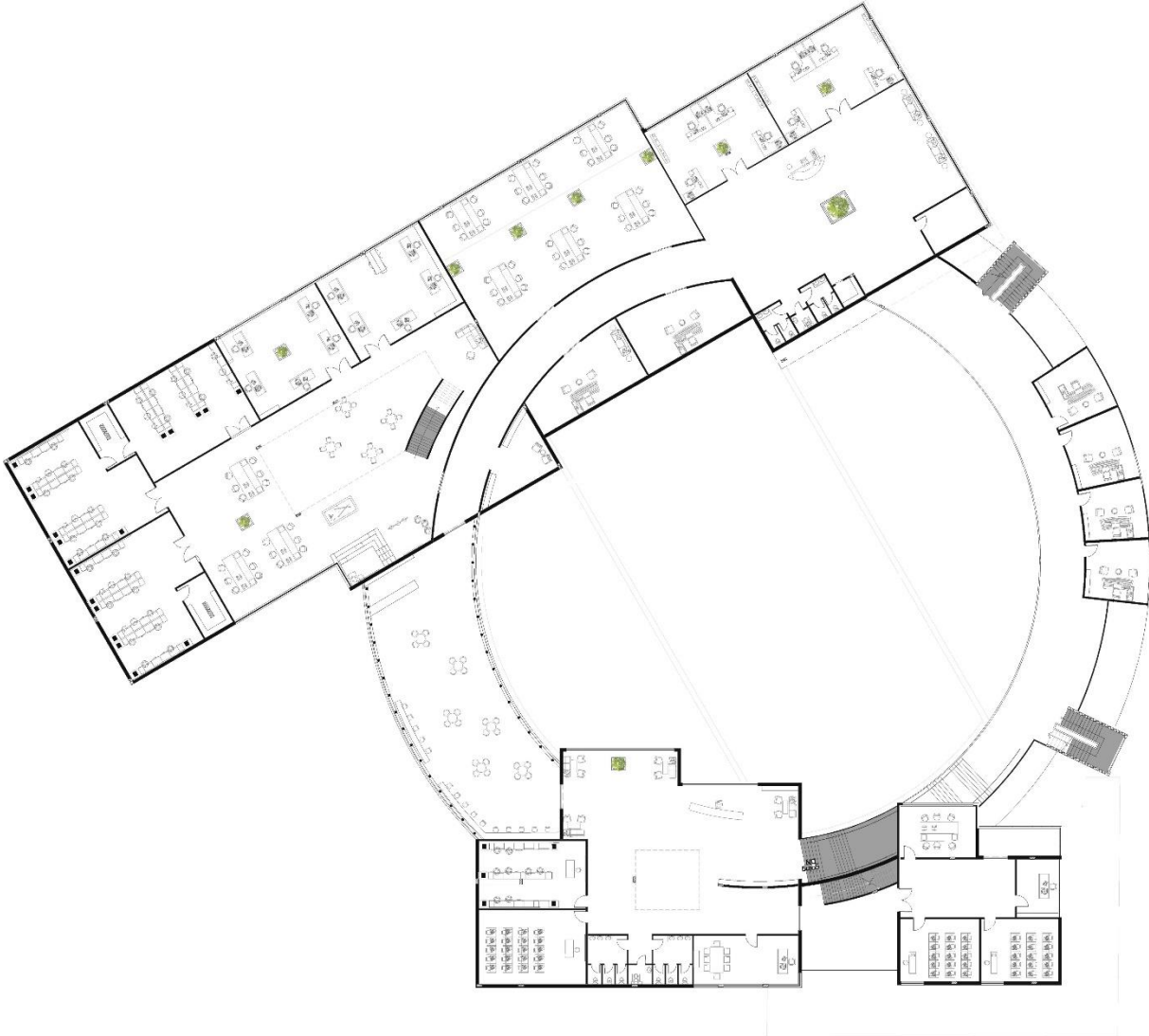

5.1.6. Section

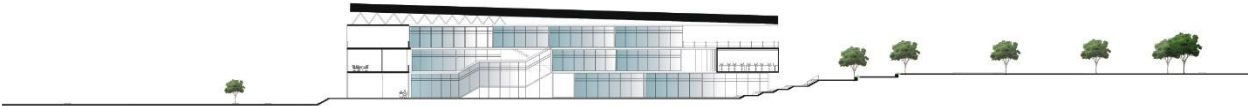

5.1.7. North Elevation

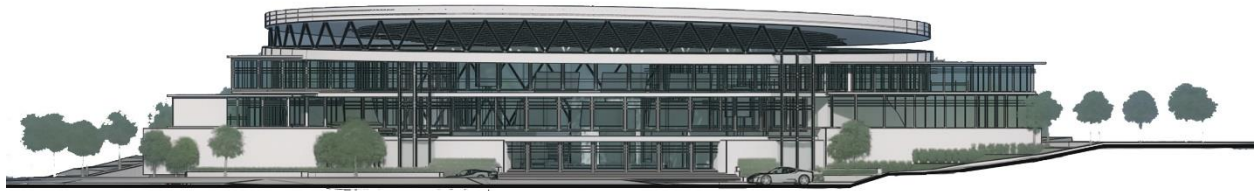

5.1.8. South Elevation



5.1.9. East Elevation

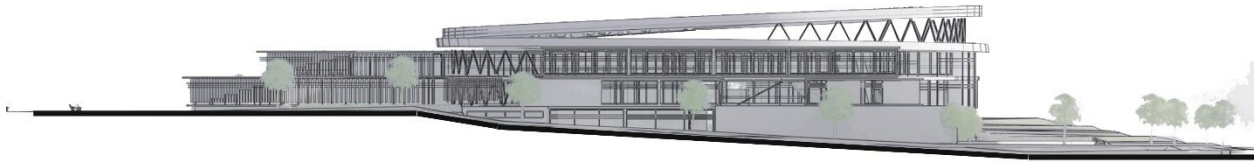

5.1.10. West Elevation



5.2 Exterior shots







5.3 Interior shots





References:

1. Ken Funk, 2022, Oregon State University.
<https://web.engr.oregonstate.edu/~funkk/Technology/technology.html>
2. Linda Rosencrance, 2022, Software, TechTarget
<https://www.techtarget.com/searcharchitecture/definition/software#:~:text=Software%20is%20a%20set%20of,that%20run%20on%20a%20device>
3. Mr.Sameer Ibrahim AbdelHadi, 2022, Samco's company founder, Interview.
4. Steve Jobs, 2011, proposal for a new Apple Campus to the Cupertino City Council, the Cupertino Community Hall.
https://www.youtube.com/watch?v=gtuz5OmOh_M&t=506s.
5. Matt Hickman, 2020, International News Professional Practice, The Architect's Newspaper
<https://www.archpaper.com/2020/04/foster-partners-imposes-staff-furloughs-pay-cuts/>
6. Duncan Sinfield, 2020, Apple Park, apple insider
<https://appleinsider.com/inside/apple-park>.
7. Norman Foster, 2020, Apple Park, MIT Media Lab.
<https://www.youtube.com/watch?v=KZ-y6E9LPP4>
8. Apple Media Helpline, 2017, Apple Park opens to employees in April , Newsroom
<https://www.apple.com/newsroom/2017/02/apple-park-opens-to-employees-in-april/>
9. Patrick Lynch, 2018, Employees Keep Walking into the Glass Walls at Apple's New Campus, Archdaily
<https://www.archdaily.com/889184/employees-keep-walking-into-the-glass-walls-at-apples-new-campus#:~:text=The%20Apple%20Park%20campus%20features,workstations%20into%20larger%20social%20areas>.
10. Tech Vision, 2020, Inside The \$5 Billion Apple Headquarters
<https://www.youtube.com/watch?v=FzcfZyEhOoI&t=70s>
11. Steven Leuy, 2017, One More Thing, Inside Apple's Insanely Great.
<https://www.johngrimwade.com/blog/2017/06/15/apples-new-home/>
12. Abdullah Al Sabbir 2021 <https://olefinsbd.com/access-control-system-bangladesh/>
13. Chris Farquhar 2022 <https://study.com/academy/lesson/access-control-types-implementation.html>
14. Sean Peek 2022 <https://www.businessnewsdaily.com/9067-choosing-a-surveillance-system.html>
15. ILLUMINATING THE PATH TO SOLAR 2022 <https://ilumsolar.com/the-3-types-of-residential-commercial-solar-power-systems/#:~:text=The%20three%20types%20of%20solar,generation%20and%20power%20storage%20experience>.

16. Vectorsolutions, EHS Management, 2013
<https://www.vectorsolutions.com/resources/blogs/understanding-the-importance-of-emergency-exit-routes/#:~:text=Emergency%20exit%20routes%20are%20important,during%20a%20disaster%20or%20crisis.>
 17. Peter Nischwitz, 2020,glastory , Insulating glass product types
<https://www.glastory.net/insulating-glass-types/>
 18. Rostek-UK <http://www.rostek-uk.com/services/facade-access/facade-access.php>
 19. James Freeman <https://www.edrawsoft.com/linuxdiagram/office-layout-software-linux.html>
 20. <https://community.fs.com/blog/how-prefabricated-data-centers-are-booming-in-the-it-sector.html>
 21. <https://www.dimensions.com/collection/kitchen-layouts>
 22. <https://www.vertiqualsafety.com/en/permanent-systems-for-stairs-and-ladders>
 23. <https://cbe.berkeley.edu/mixedmode/aboutmm.html>
 24. <https://www.jomy.com/en-US/building-maintenance-units>
 25. <https://engineeringdiscoveries.com/orientation-of-building-with-sun-purpose-and-factor-affecting/>
 26. <https://www.glassonweb.com/article/sound-insulation-facade-element-with-triple-igu>
 27. <https://thearchitectsdiary.com/airbnb-offices-designed-with-core-identity-and-belong-anywhere-philosophy-gurgaon/>
 28. <https://www.ptraccess.com/different-types-of-access-control-systems/>
 29. <https://www.agtelecom.in/product/proximity-access-control-system/>
 30. <https://www.archdaily.com/982732/powerhouse-company-reveals-ibm-headquarters-in-amsterdam>
 31. <https://officesnapshots.com/2016/02/01/atlassian-offices-austin/>
 32. <https://www.philippayne.co.uk/knowledge/emergency-lighting-design-guide-light-levels/>
- 1.
 2. <https://thiendang.net/en/team/heating-ventilation-air-conditioning/>
 3. <https://www.trioarquitetura.com.br/>
 4. Websites for site analysis :
 1. Geomolg
 2. GIS
 3. SunCal
 4. ArcGis
 5. Google maps
 6. Cadmapper
 7. Open Street Map
 8. Civil 3D
 9. Ventusky
 10. MapBox
 11. The Pudding