



An-Najah National University

An-Najah National University Faculty of Engineering

Electrical Engineering Department

DUAL AXIS SOLAR TRACKER

BY:

Eng. Ali Bsharat.

Eng. Lana Saed.

Eng. Malak Azzam.

SUPERVISOR:

Dr. Raed Jaber.

**Presented in Partial fulfillment of the requirements for Bachelor degree in
"Electrical Engineering "**

Date: 2022-2023

TABLE OF CONTENTS:

Acknowledgements.....	
List offigures.....	(2-3)
Abstract.....	(4)
Chapter 1:	
1.1 Overview	(6)
1.2 EXISTING PROBLEMS.....	(7)
1.3 PROJECT OBJECTIVE.....	(8)
1.4 Types of solar panel bases and the difference between them.....	(8-10)
1.5 What is a solar tracker and how does it work	(10-11)
1.6 Types of trackers.....	(11-15)
1.7 Scope of work for the project.....	(15)
Chapter 2:	
2.1 What is an Arduino dual Axis solar tracker.....	(17)
2.2 Working	(17-18)
2.3How does dual axis solar tracker work.....	(19-21)
2.4 Solar Angles.....	(22-23)
2.5 Control method of normal tracking.....	(23)
Chapter 3:	
Methodology.....	(24-50)
3.2 Hardware system	(25-30)
3.2.1 Block Diagram.....	(26)
3.2.2 AutoCAD.....	(27)
3.2.3 SketchUp.....	(27)
3.2.4 Electrical Circuit Design.....	(28-30)
3.3 .Hardware description.....	(31-44)
3.3.1 Tools.....	(31-33)
3.3.2 Design of Sun tracking mechanism	(33-35)

3.3.3. Arduino UNO Controller.....	(36-37)
3.3.4. Solar Panel	(37-38)
3.3.5. LDR(<i>resistance sensor</i>).....	(38)
3.3.6. Servo Motor	(39)
3.3.7 solar panel controller	(41)
3.3.8 power inverter	(43)
3.3.9 battery12 volt	(44)
<i>3.4. The embedded software design.....</i>	<i>(45-50)</i>
Chapter 4:	
economic analysis of project.....	(51-66)
4.1.Introdaction	(52)
4.2 Project methodology	(53-57)
4.2.2 Electrical wiring diagrams for hospital floors	(53-55)
4.2.2Annual averages.....	(55-57)
4.3. Tracking system specification.....	(58-60)
4.3.1. Economic System Analysis.....	(61-65)
4.4.CONCLUSION	(66)
Chapter 5:	
CONCLUSION	(68-69)
Chapter 6 :	
References	(70-71)

ABSTRACT:

The most plentiful renewable energy source on Earth is solar energy. It is one of the greatest fossil fuel substitutes and is regarded as a reliable, low-risk renewable energy source. The sun provides solar energy, which may be harnessed in a variety of ways.

The solar energy system we will utilize for this project is the solar energy tracking system, which places an item at an angle with regard to the sun. One of the most common applications for solar trackers is positioning solar panels (photovoltaic panels) so that they remain perpendicular to the Sun's rays and can determine the proper Sun's direction. Solar trackers change the direction a solar panel faces in response to the Sun's position in the sky. More sunlight is received by keeping the panel perpendicular to the Sun. less light is reflected and more energy is absorbed when it hits the solar panel. It is possible to turn the energy into power. Less light is reflected and more energy is absorbed when something hits the solar panel. It is possible to turn the energy into power.

Solar tracking system is mainly of two types: Single-axis solar tracking system and Dual-axis solar tracking system.

This project will demonstrate how to build a dual-axis solar tracker using Arduino.

Dual-axis trackers are able to move in two directions, so they always face the sun.

Azimuth-altitude and tip-tilt are two instances of kinds. Positioning a mirror and directing sunlight along a fixed axis onto a stationary receiver are common applications for dual-axis tracking. Since they monitor the sun both vertically and horizontally, these trackers aid in generating the most solar energy possible at any one time.

CHAPTER 1

INTRODUCTION

OVERVIEW

Solar energy and solar cells started from the creation of God Almighty for the sun because it is the first source for generating thermal energy and then it became generating electrical energy, so the man used to benefit from the energy of solar radiation in drying crops, agriculture and other things. Thermal transfer occurs when solar or light radiation is converted into electrical energy by solar cells through the techniques of photoelectric conversion and thermal conversion of solar energy. Einstein was the first scientist to identify this event, and he was awarded the Nobel Prize in 1921 for his explanation of this cosmic occurrence.

Sun cells are unique in that they produce electricity by directly converting solar energy into electricity without harming the environment.

Due to the rising demand for electricity, renewable resources are currently one of the main issues, although conventional energy sources' quality and availability are insufficient. Any nation in the world can only develop if it has access to energy. Fossil fuels are primarily used in the generation of energy. Energy from renewable resources like solar, geothermal, and tidal wave energy is becoming more and more necessary; because the supply of fossil fuels is finite. The photovoltaic "PV" system has the greatest potential among all renewable energy sources to displace current energy sources. The only way to improve a solar panel's performance is to intensify the light that hits it. The best technology is solar tracking by maintaining the solar panel aligned with the position of the sun, to maximize solar panel efficiency.

A system that tracks the sun as it moves across the sky is called a solar tracker.

Together with solar panels, the latter may follow the path of the sun and produce more renewable energy for your needs.

EXISTING PROBLEMS

Palestine faces major problems in electricity due to the increase in population density, the weather conditions, and also the increase in electrical loads on transformers within cities, whether they are from factories, homes, or any human interests.

The Palestinians have sought to bypass this dilemma by finding alternative sources of traditional fuel through solar energy sources that are generated from sunlight. Solar energy is considered the best solution to produce clean electrical energy as it is free energy and does not cause any pollution when generated, but the problem is that all panels The solar panels that he made at the present time only benefit from a small percentage of the sun's energy, and the matter is due to two reasons, the first is the inefficiency of the solar panels, and the second reason is the continuous movement of the sun, which does not make the sun's rays hit vertically on the panels, and here work began to solve this dilemma with The sun tracking system, which is a device or circuit that directs the solar panels that are mounted on a moving axle of the sun's rays to take full advantage of its rays, which is the main goal of our project (tracking the sun's rays and the rotation of cells towards it).

In this project, we will present a partial solution to this problem that causes a lot of dilemmas for our country, which is that solar cells follow the sun's rays in the sky wherever they go, meaning to take advantage of the sun's rays from sunrise to sunset to generate solar energy, and this saves 30% more energy than other common methods.

PROJECT OBJECTIVE

The main objective of the project is to make use of the largest possible amount of sunlight to develop facilities in Palestine and other countries that use old technologies.

As well as getting to know the term solar energy and how to benefit from it, and how to connect it.

TYPES OF SOLAR PANEL BASES & THE DIFFERENCE

FIXED SOLAR PANEL BASES: It is assembled and installed in the right place, as this type is fixed in direction and angle, that is, direct sunlight cannot be tracked during the day.

* The process of assembling the bases using screws or a welding machine.

* Cheap price compared to mobile bases.



Figure 1. Fixed solar cells

MOVING SOLAR PANEL BASES:

The inclination angle of the solar cells is adjusted and varied in this type. In order to maximize the solar system's productivity, a "tracker" motor is also added, which tracks the sun's rays and moves the cells throughout the day so that they are always perpendicular to them. The sun moves along two axes from east to west during this movement.



Figure 2. Moved solar cells

The moving bases follow the sun in one axis and in two axes, which is the basis of our two-axis tracking project to obtain greater solar energy through its rotation with the sun's rays throughout the day.

ADVANTAGES AND DISADVANTAGES OF FIXED AND MOVED BASES:

- * Fixed bases cost less than animated bases.
 - * Moving rules give better productivity than static ones.
 - * Fixed bases do not need maintenance compared to moving bases that need constant follow-up and maintenance, because they contain moving parts.
- Our project expresses Dual Axis Solar Tracker to get the largest amount of sunlight, which is a section of the moving bases.

WHAT & HOW DOES A SOLAR TRACKER WORK?

Manufacturers of solar panels are always improving their products to produce more energy per unit than earlier and rival versions. Utilizing solar trackers, as opposed to fixed-tilt ground-mount systems, which force solar panels to follow the sun's path throughout the day, is another tried-and-true method for boosting system output.

The single- and dual-axis variants of solar trackers are the two most common varieties on the market.

Single-axis solar trackers move in unison, by panel row, or by section as they revolve around a single point and track the sun from east to west. Solar panels can directly follow the sun using dual-axis trackers since they can move on both the X and Y axis.

TYPES OF TRACKERS

The two categories of solar tracking equipment are single axis trackers and dual axis trackers.

SOLAR TRACKERS WITH A SINGLE AXIS:

Your panels are moved by a single-axis tracker, which is frequently parallel to north and south. Without the need to install extra solar panels, these designs allow your solar panels to track the sun from east to west and as it rises and sets, increasing the effectiveness of your system. Despite their high initial installation costs and continuing maintenance expenditures, single-axis solar trackers can increase the efficiency of your solar system to the point where your investments are soon recouped. It is best to install a single-axis tracking system on flat ground in a typically warm and dry climate.

In order to tilt the angle of incidence of solar radiation toward the vertical when photovoltaic panels are installed, the axis is also changed, depending on the position and either the East to West or the North to South orientation of the panels.

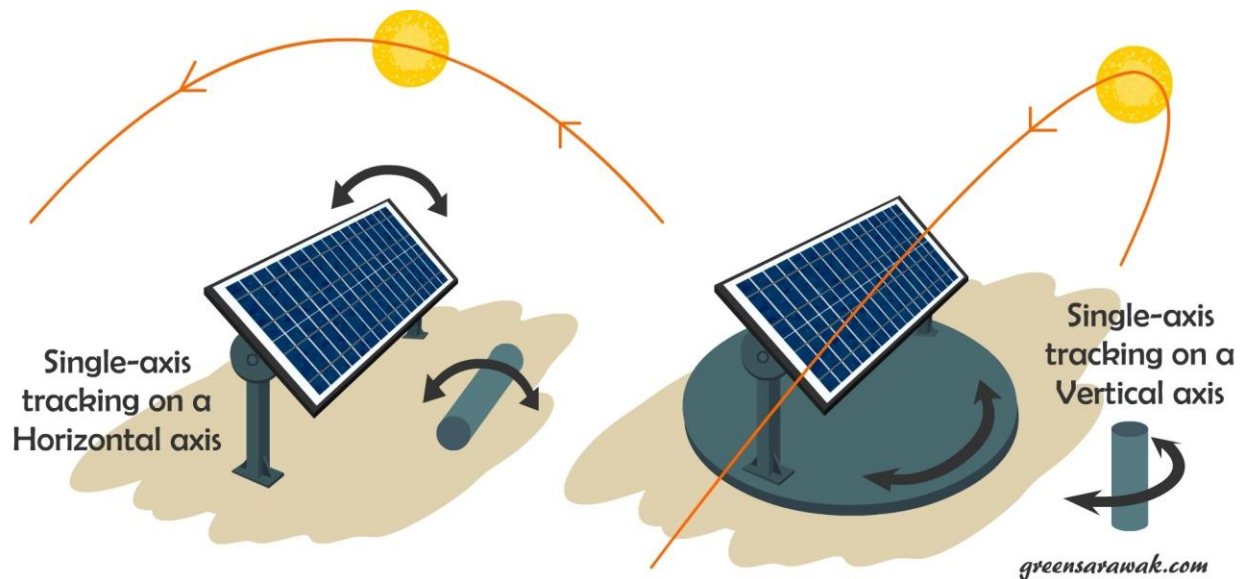

Figure 3. Single axis tracker

• SINGLE-AXIS SOLAR TRACKING SYSTEM BENEFITS

• • One degree of flexibility serves as the axis of rotation for single-axis trackers, which is commonly oriented along a North-South axis. Single-axis trackers offer the following noteworthy advantages:

- • They are more dependable.**
- Due to their reduced operating costs and more straightforward mechanisms, single-axis trackers are more cost-effective than dual-axis trackers. For companies with a limited budget or locations that are frequently foggy, single-axis trackers are suitable.-Single-axis trackers are around 32.17% more efficient than a panel with a fixed solar tracker mount because they follow the Sun from East to West and provide constant power production throughout the day.**

In comparison to a static plant with the same installed capacity, the trackers produce 15–16% more power annually.

PV panel deployment density per square is maximum on single-axis trackers. The investment in the solar project has a quicker payback period, and the profits are substantially larger.

The solar panel system could need a few more components and gears for the installation of a solar tracking system, and they periodically need maintenance.

THE SINGLE-AXIS SOLAR TRACKING SYSTEM HAS SOME DRAWBACKS.

In sunny conditions, single-axis trackers produce less energy than dual-axis trackers do, and there has been little technological advancement.

Single axis trackers are less costly than dual axis trackers because of their simple mechanism and low running expenses. Single-axis trackers should be used by companies with constrained resources or by places that experience regular cloud cover. About 17% more power is produced by single-axis trackers than by stationary trackers.

DUAL-AXIS SOLAR TRACKERS:

Dual Axis Solar Tracker The main title of the project, where this type of system is designed to increase the collection of solar energy throughout the year to rotate in all directions (north, south, east and west) and track the sun's rays to obtain and store the largest possible amount of sun.

Your panels can move on two axes that are both aligned north-south and east-west when using a dual-axis tracker. Through the use of algorithms and sensors that monitor seasonal variations in the height of the sun in addition to regular daily movements, This kind of arrangement is designed to optimize the solar energy you can collect all year round. Dual-axis trackers (made by companies like All Earth Renewables) are normally a much less common alternative, even in large, utility-scale solar systems. Due to the constrained amount of commercial rooftop space available for the installation of solar panels, dual-axis trackers, which may generate up to 45% more energy than traditional static panels, are being used, may be appropriate in some commercial properties. These systems can help businesses produce enough power to run their operations in a small space. Dual-axis setups are frequently not needed because utility-scale installations are frequently built on large pieces of land without the space constraints of a commercial roof area.

The most precise placement of the solar panel is made possible by dual-axis tracking, which is also expected to boost output by 40% through energy absorption. However, these solar trackers are more costly and intricate.



Figure 4. dual-axis trackers

DUAL-AXIS SOLAR TRACKING SYSTEM BENEFITS:

Dual-axis trackers continuously follow the Sun and offer steady power production all day long.

These solar trackers provide a practical alternative when the grid connection has a constrained power capacity.

Dual-axis trackers take up less area, allowing you to utilize it for other purposes such as car parking, gardening, and other activities.

***Dual-axis trackers offer the greatest choice for situations where solar production may be affected, producing 45-50% more electricity yearly than a static station with the same installed capacity.**

These sites may include ones with a complex ground structure, intricate relief, stone protrusions, a drop to the North, and others.

Dual-axis trackers provide a shorter payback period than other types of trackers. Additionally, during their lifetime, revenues will rise significantly.

DUAL AXIS TRACKERS' DRAWBACKS INCLUDE:

- o Component failure is more likely when there are more moving parts.
 - o Shorter lifespan and decreased dependability.
 - Performance issues in cloudy or overcast conditions.
- o Expensive. Compared to static panels, can produce 40% more electricity, but costs 100% more.

WE WILL EXPLAIN THE WORKING PRINCIPLE OF THE PROJECT THAT TALKS ABOUT DUAL AXIS TRACKER.

SCOPE OF WORK FOR THE PROJECT

One of the most well-liked projects lately is the dual-axis solar tracker. It is merely a mechanism that tracks sunlight in accordance with its intensity. It can boost the amount of power that a light solar system is able to gather from the sun.

The solar panel is part of a system that tracks the sun in all four directions. For instance, the direction of the sun varies depending on the time of day.

The light solar tracker thus follows the light source that emits the most power with the greatest intensity. Before starting this project, we may estimate the store utilizing both a regular solar panel system and a solar panel with an automated solar tracker. Solar trackers may boost electricity output by 30% compared to a standard arrangement.

CHAPTER 2

GENERAL DESCRIPTION OF THE PROJECT

WHAT IS A DUAL-AXIS SUN TRACKER

- One of the most well-liked recent Arduino projects is the dual axis solar system project.
- It is merely a mechanism that moves in accordance with the strength of the sun.
- It can improve the amount of power the solar system is able to gather from sunshine.
- A device that follows the sun's beams in all four directions and has a solar panel on it. For instance, as time goes on, the sun's direction changes. Since it generates the most power and stores the most light energy, solar trackers follow the light with the maximum intensity.

The dual-axis solar tracker not only tracks the sun's path from east to west but also its angular height position. Similar to single-axis systems, dual-axis systems spin their axis along vertical and horizontal axis, making them more effective at gathering solar energy.

WORKING

By allowing PV panels to rotate along two separate axis, the suggested tracking system more accurately follows sunlight.

The tracker is composed of four LDR sensors, two stepper motors, and a PIC microprocessor. Two sensors and one motor are used to tilt the tracker in the direction of the sun's east-west beams.

By utilizing the second set of sensors and the motor located at the bottom of the gadget, the tracker is tilted in the north-south direction of the sun.

In this configuration, a total of two servo motors are employed. The linear and parabolic motions of the sun are tracked by the stepper motors of the base and upper panel holders, respectively. A CPU is connected to these stepper motors and sensors. Based on information from the sensors, the microcontroller instructs the motors. When they detect light, LDR sensors alert the microcontroller with a signal.

DUAL AXIS SOLAR TRACKER: HOW DOES IT WORK?

when solar cells are exposed to light. It begins figuring out and comparing which direction the sun's strongest rays are coming from.

The system starts to raise its intensity after comparing the panel above, such that the solar panel generates the most power and has the maximum intensity.

"The maximum power conversion is directly inversely proportional to the maximum light intensity."

- In this instance, the resistance value of the LDR sensor, also known as a light dependent resistor, would drop as more sunlight falls on it.
- This indicates that solely light is used to modulate resistance. So, we are employing this technique. The dual axis solar system will move in the direction where the LDR sensor reduces the maximum resistance.
- This is the project's guiding principle. There, two servo motors are being used to assist in moving the panel in all directions. Arduino assists with all calculations, processing, etc.
 - The LDR Sensor's straightforward Arduino operation.
 - A single-axis solar tracker is another option.

THERE ARE THREE WAYS TO RELOCATE A SOLAR TRACKER:

- * **Manual** - A few staff are sent out at various points during the day to manually move the solar tracker. This tracking technique is economically viable in underdeveloped countries with inexpensive labor.

The solar tracker has a liquid bulb that heats up when it is exposed to the sun and is classified as passive. The outcome is that the liquid evaporates. This volume expansion pushes and tilts the linked solar tracker toward the sun.

- * **Active** - Electric motors or hydraulic cylinders change the tracker's placement.

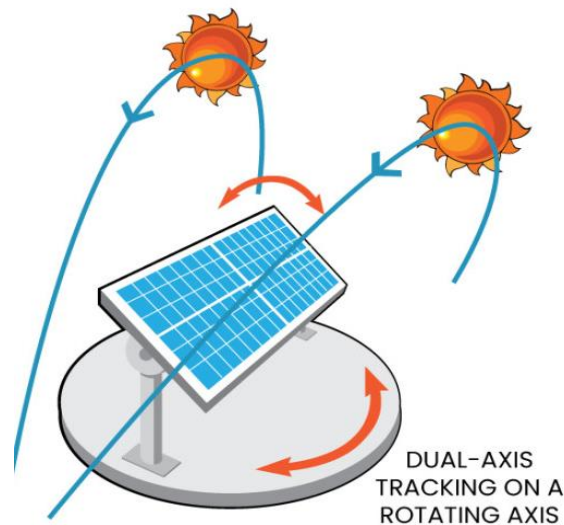

Figure 5. Dual Axis tracker

MODEL SHOWING THE FREEDOM OF MOVEMENT OF THE DUAL - AXIS TRACKING SYSTEM:



AXIS OF ROTATION:

Based on the axis of rotation, there are three primary categories of solar trackers:

- **Horizontal** - the tracker spins on the North-South axis and has one degree of freedom. Most significant commercial applications and low to medium latitudes employ this kind of tracker.
- **Vertical** - the tracker spins on the East-West axis and has one degree of freedom. High latitudes frequently employ this kind of tracker, although major commercial uses are rare.
- **Dual Axis:** The tracker rotates in two directions (East-West and North-South), giving it two degrees of freedom. All latitudes can use this kind of tracker, but it is not frequently employed for extensive commercial purposes.

SOLAR ANGLES

• The inclination angle varies from -90° following sunrise to $+90^\circ$ before sunset, crossing 0° at noon. Due to this, solar radiation is gathered at 0% during dawn and dusk and 100% at noon. More than 40% of the solar energy is lost by the photovoltaic panel as a result of this change in solar radiation collecting. To maximize the capture of solar energy, we walk you through creating a solar tracker in this project.

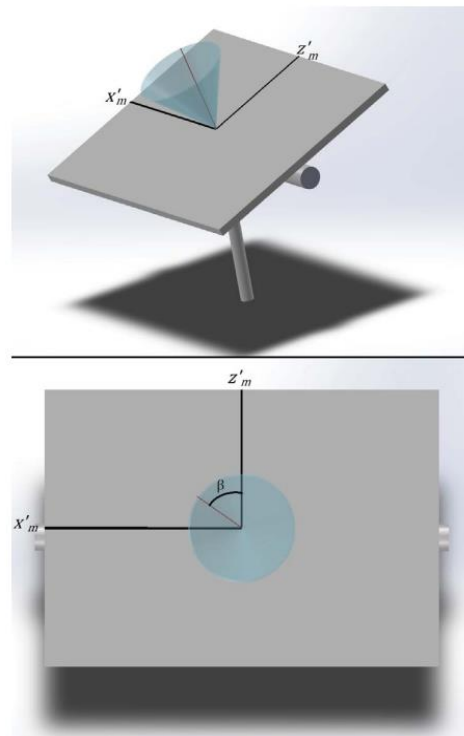
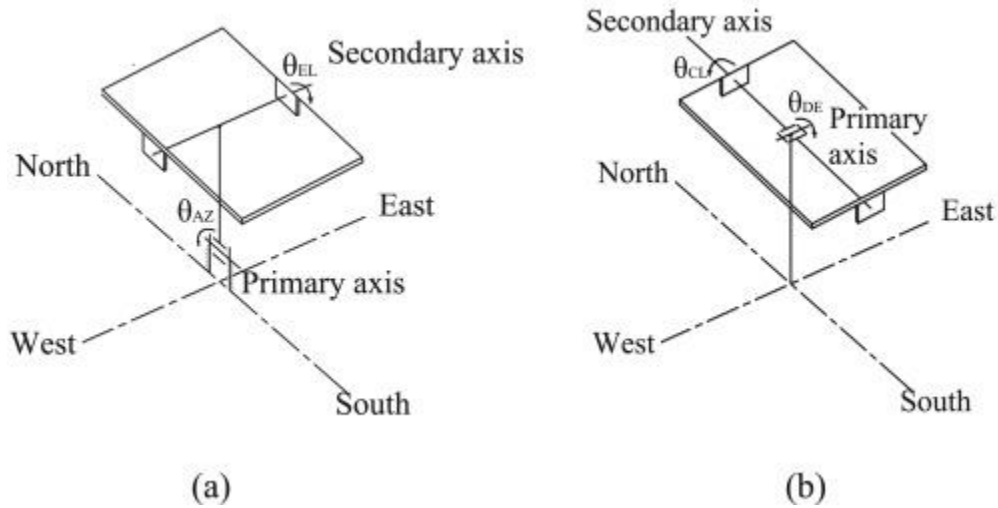

Figure 2: (Top) An isometric view of a solar tracker with reference axes. The red line indicates the direction of the sun, the cone indicates all possible sun positions with the same AOI (α) relative to the tracker. (Bottom) Direct view of the face of the tracker with β identified.

Figure 1(a) and (b) compare the pseudo-azimuthal tracker and the developed tracker's tracking schematics.



The position of the sun affects the tracker's rotation angles. Consequently, the solar collector's unit normal vector is given by

$$\mathbf{n} = \mathbf{v}_s$$

where \mathbf{v}_s is the unit vector incident to the sun, and \mathbf{n} is the solar collector's unit normal vector. In general, the sun azimuth angle and altitude angle can be used to calculate the vector versus.

Analysis of declination-clock mounting system

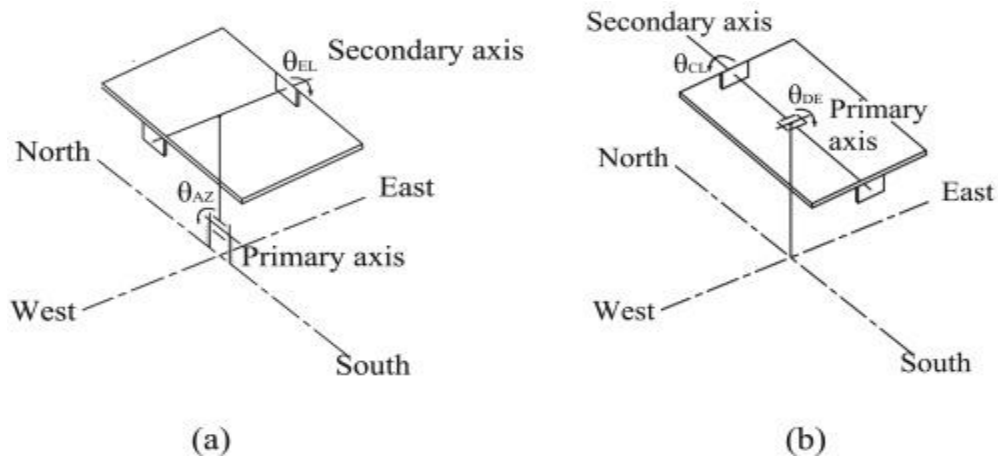

CONTROL STRATEGY FOR REGULAR

As seen in Fig., the microprocessor can use solar time to estimate the sun's location. The sun position sensor may also send messages to the CPU. The primary and secondary axis motors are under the direction of the microprocessor, which realizes the motion of the mechanical system. Since the microprocessor and personal computer are connected, tracking accuracy may be monitored in real time.

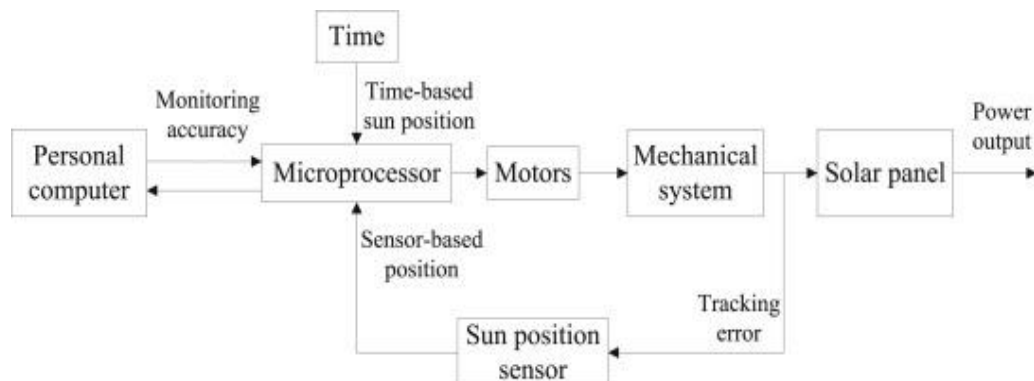

CHAPTER 3

METHODOLOGY

HARDWARE SYSTEM

A gadget is positioned at an angle with respect to the sun using a solar tracker.

In order for solar panels (photovoltaic panels) to precisely determine the direction of the Sun and maintain their perpendicular alignment to its beams, solar trackers are most usually employed to orient them. Solar trackers adjust the direction of a solar panel's look in response to the Sun's location in the sky.

As long as the solar panel remains parallel to the Sun, more light enters the device, less light is reflected, and more energy is absorbed. Power may be produced using that energy.

I'll demonstrate how to build a dual-axis solar tracker using an Arduino, a 4ldr, 100k resistors, and 2 servo motors in this project. Dual-axis trackers are able to move in two directions, so they always face the sun. Tip-tilt and azimuth-altitude are a couple types. Dual-axis tracking is typically used to erect a mirror and point sunlight at a stationary receiver along a fixed axis. Since they monitor the sun both vertically and horizontally, these trackers now contribute to the production of the greatest solar energy.

as demonstrated below:

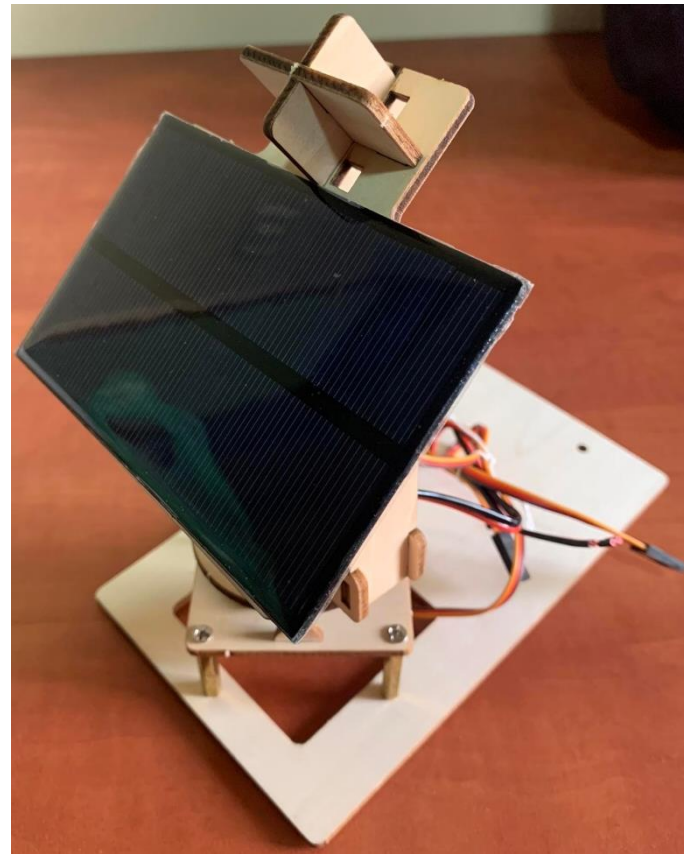

We enlarged the project model so that the 18-volt solar panel charges a 12-volt battery through the controller, and then transfers electricity from the battery to the load by using an inverter. Each part of this goal is explained.



Working:

LDRs are the main light sensors. Two servo motors are used to attach the solar panel support structure to the structure. LDRs measure the amount of sunlight that strikes them. The four LDRs are divided into top, bottom, left, and right.

- For east-west tracking, the analog values from two top LDRs and two bottom LDRs are compared, and the vertical servo moves in the direction indicated by the top set of LDRs if the top set of LDRs receives more light.

The analog data from two left LDRs and two right LDRs are compared to estimate the angular deflection of the solar panel. If the right set of LDRs receives more light than the left set of LDRs, the horizontal servo moves in that direction; conversely, if the left set of LDRs receives more light, the horizontal servo moves in the opposite way.

Block diagram

A dual axis solar tracker's block diagram is shown in Figure 6. When light is detected, four LDR sensors that are close to the solar panel will illuminate. The microcontroller will receive a "activate" signal, which it will utilize to turn on the two drives and two motors.

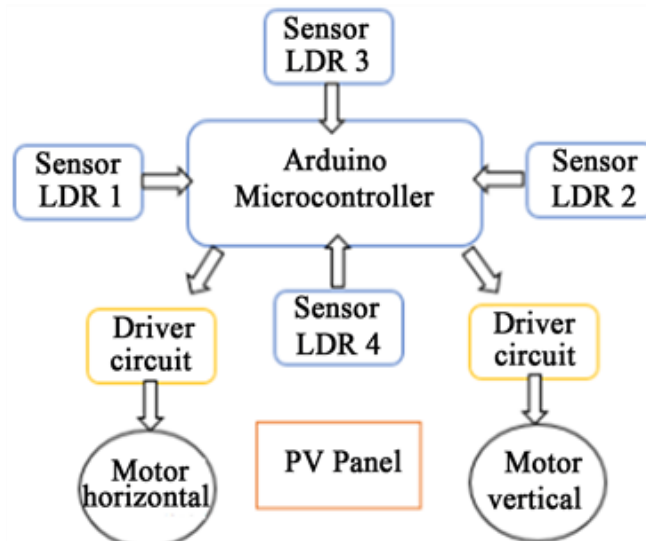

Figure 6. Block diagram.

AUTOCAD

A computer-aided drawing tool called AutoCAD may be used to design plans for structures like buildings and bridges as well as electrical components. A 2-D and 3-D software program used in architecture is AutoCAD. Figures 7 and 8 depict the dual axis solar tracker model for the hardware tracker, while Figure 7 depicts the construction process.

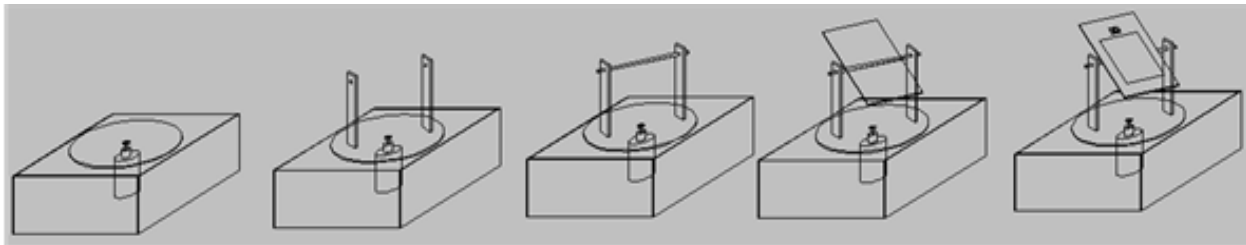

Figure 7. Process of designing the model using AutoCAD.

To support the movement of all components, Figure 8's DC motor A will whirl in the azimuth axis directions. In order to enable the LDR to detect the source of sunlight, the top DC motor B will then revolve in an elevation direction. The solar panel will be in the middle, with the circuit behind DC motor A. The solar panel will begin converting solar energy into electricity as soon as the LDRs identify sunlight.

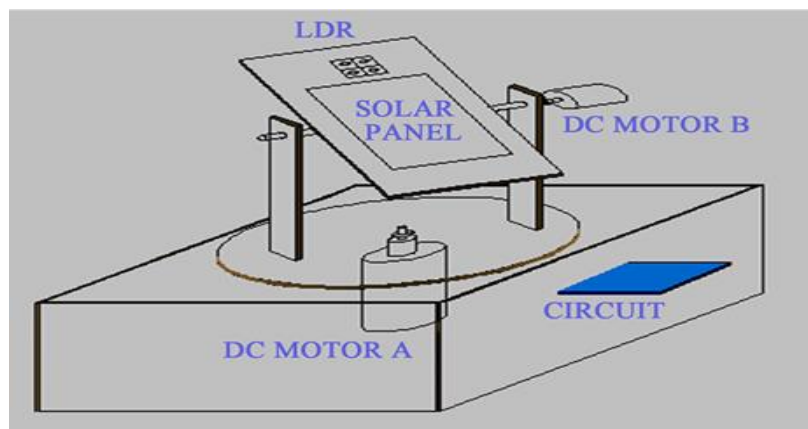
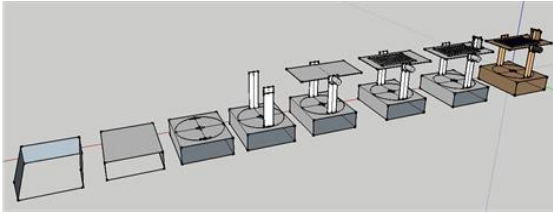

Figure 8 . The dual axis solar tracker's AutoCAD model.

SKETCHUP

Sketch Up is the most accessible tool for 3D design, documentation, and communication. For tasks like interior and architectural design, a 3D modeling computer tool called Sketch Up is employed. Figures 9 and 10 show, respectively, the hardware dual axis solar tracker design process using the Sketch Up application.



Figures 9

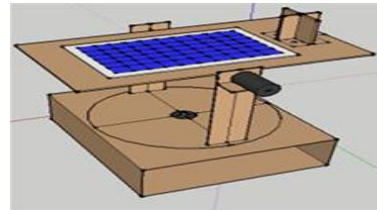

Figures 10

ELECTRICAL CIRCUIT DESIGN

Three units essentially make up the entire electrical system. These are the movement adjustment unit, the control unit, and the sensor unit. Light, time, and position are three separate parameters that the sensor unit senses and translates into the necessary electrical impulses. The control unit receives the electrical signals from the sensor unit at that point. The control unit chooses which way the motors will travel along the horizontal and vertical axes. Finally, after receiving a signal from the control unit, the movement adjustment unit changes the solar module's position.

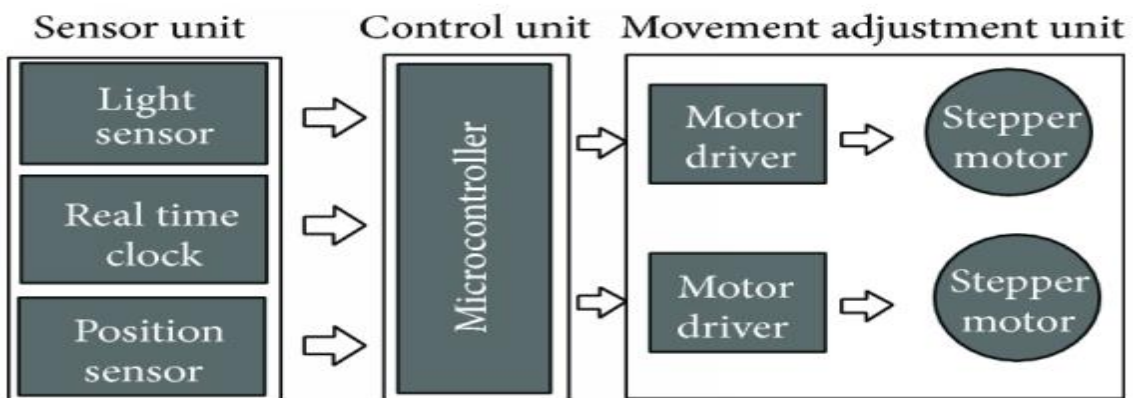

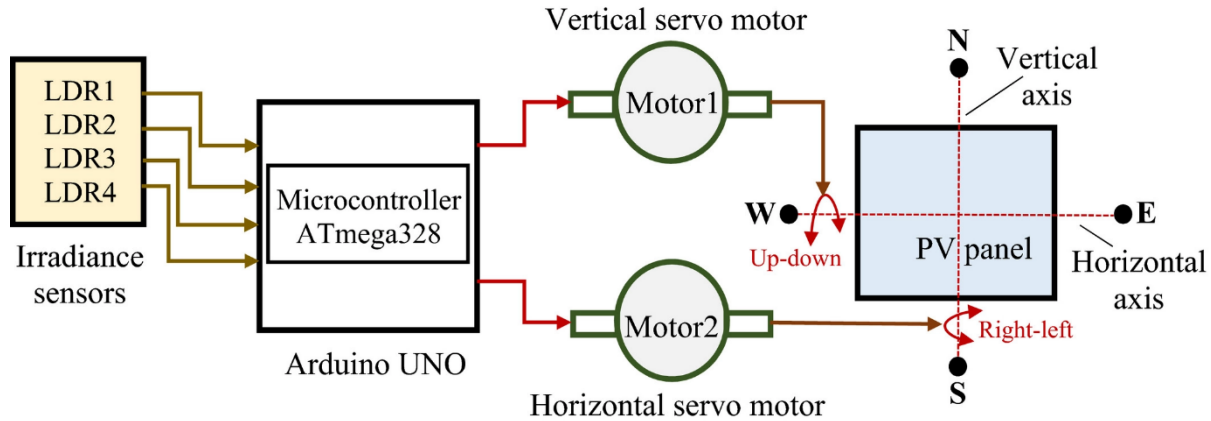

Figure 11. shows the overall block diagram of the whole system.

This block diagram gives the structural methodology of the sun tracking system:

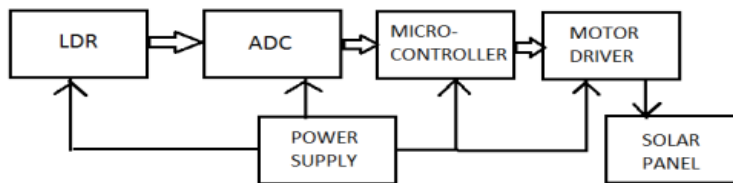

Fig. 12 design methodology

The Arduino software is set up such that the quantity of sunshine hitting the panel's top two LDRs and bottom two LDRs can be compared. The Arduino then chooses the location where the panel receives the most sunlight and sends a command to one of the motors to move the panel in that direction.

if the bottom two LDRs receive more sunshine, it will move the panel in the direction of the south, and otherwise, it will move the panel in the direction of the north. This is the how one motor works.

The panel is then moved using the second motor in either an eastward or a westward direction. Similar to the previous instance, the code provided to the Arduino in this instance specifies that the LDRs located on the panel's left side are taken as one pair, while those located on the panel's right side are taken as the other pair. The Arduino directs the motor to move in the left direction when the area on the left receives more sunlight than the area on the right.



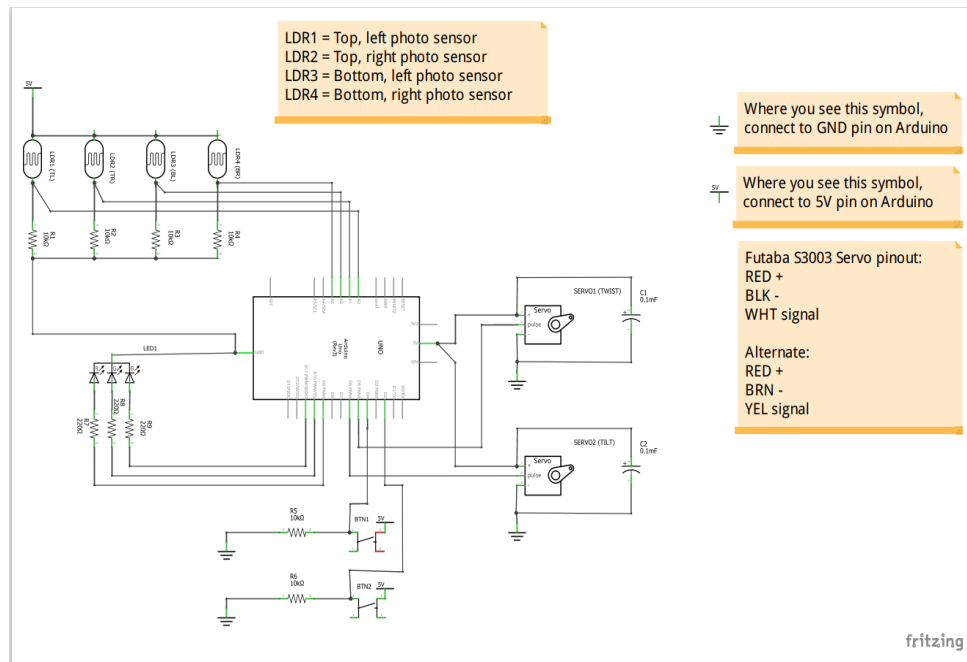

Similar to this, it travels toward the right side when it receives more. This is how the second motor functions.

Finally, the panel can be moved in both axes by installing two motors.

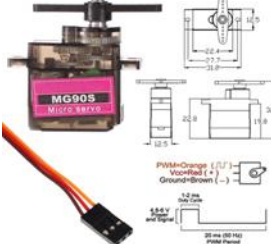

TOOLS:

Table no. 1: Components ratings & Specifications

Name of Components	DIAGRAM	Specification	Function
<p style="text-align: center;">Arduino Uno R3</p>		<p style="text-align: center;">ATmega328P</p>	<p style="text-align: center;">The Arduino UNO is a source microchip ATmega328P microcontroller & developed by Arduino's.</p>
<p style="text-align: center;"><i>USB</i></p>			<p style="text-align: center;">You can power and program your preferred Arduino board using the USB Cable for Arduino UNO/MEGA. They can be removed for the board.</p>
<p style="text-align: center;">2 x 9g Metal Gear Servos</p>		<p style="text-align: center;"><i>model MG90S</i></p>	<p style="text-align: center;">Included in the box: the package Model MG90S two-piece small servo metal gears are an upgrade over SG90 in terms of durability and noise reduction.</p>
<p style="text-align: center;"><i>LDR (resistance sensor)</i></p>		<p style="text-align: center;">GND, VCC, SIG (GND is the ground, VCC is the power supply, and SIG is the signal output pin) Photo resistance Model: GM5528</p>	
<p style="text-align: center;"><i>Solar Panel</i></p>			<p style="text-align: center;">Solar panel: 0.45W Polycrystalline Silicon Solar Epoxy Panel. Solar garden lighting. Outdoor solar advertising. Included: 1/2 X Solar Panels.</p>

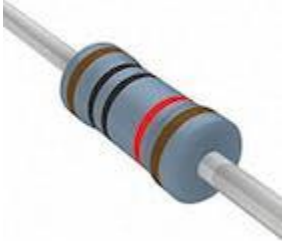
<p>Jumper Wire</p>		<p><i>jumper wires (10+10+10)</i></p>	<p>These male to female jumper wires are used to link the female header pin of one development board (such as Arduino) to another development board with a male header pin.</p>
<p>4*10K Ohm resistor</p>			<p>Typical axial-lead resistors with 10K ohm carbon film resistance have substantially higher temperature stability and offer less noise..</p>

The suggested remedy has been used in this project and is Tinker CAD. A very user-friendly interface is available in Tinker Cad for creating CAD models and circuits. It also includes a variety of other parts, including an Arduino UNO, integrated circuits, and other electronic parts.

A hardware model has also been created in addition to the model's software implementation. The hardware model uses a Sun-tracking Mechanism to boost the efficiency of a solar panel.

In order to increase efficiency, the model establishes a proof of concept.

DESIGN OF SUN TRACKING MECHANISM

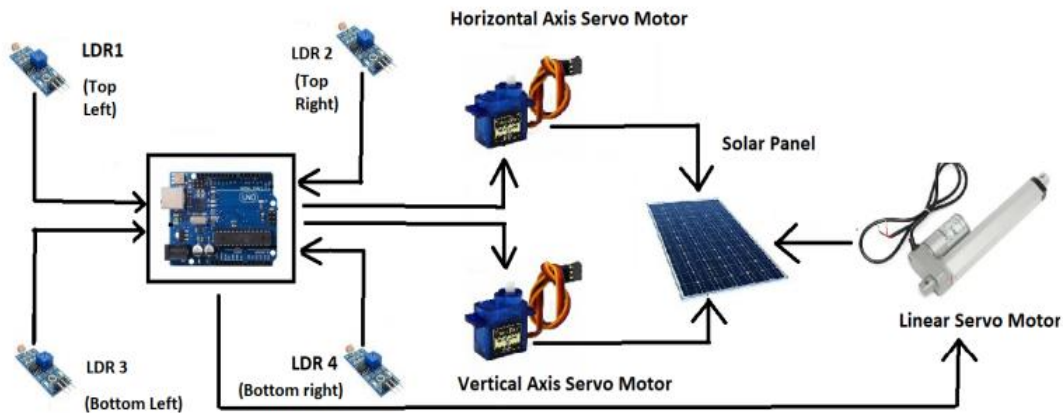

Figure depicts a schematic of the sun tracking system mechanism. Figure 1 shows that there are a total of four LDRs, each of which can detect light coming from one of four directions.

The controller receives the intensity values. The corner of the panels 28 will be built in accordance with the general plan of the Tubas Turkish Governmental Hospital (Tubas City), the area chosen for the project, thanks to the controller's analysis of those values and output to the corresponding servo motors.

The solar panel is then rotated by these actuators to optimize the amount of sunlight hitting it.

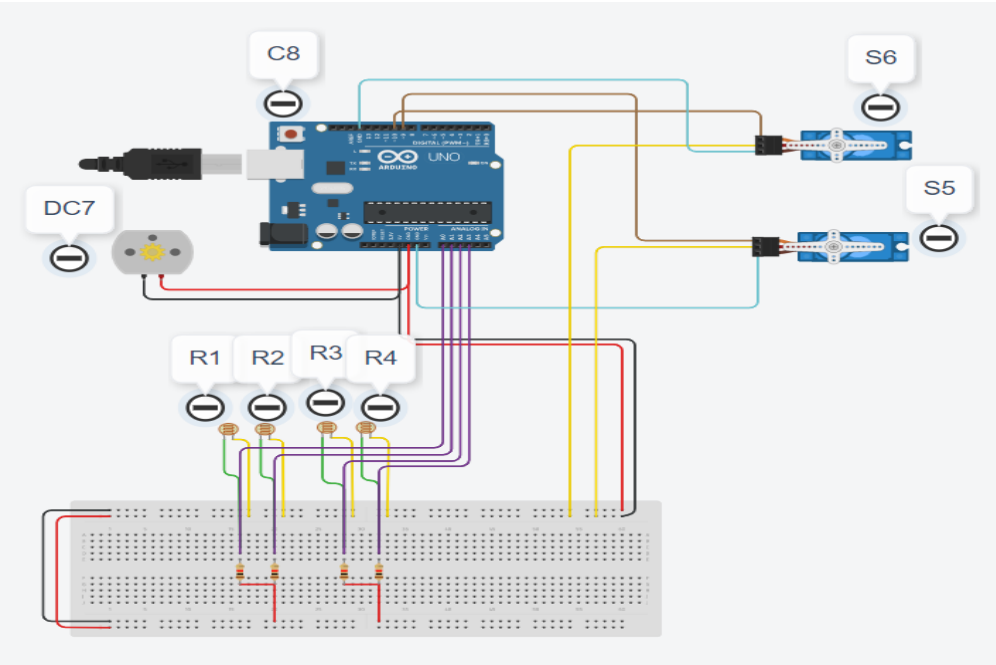

Figure 13. Design of sun tracking system

Figure 11 illustrates how the sun tracking system was created in the online Tinkercad environment. The table above lists each of the components that were used. Four LDRs have been linked in the circuit above to measure the intensity of the sun from all angles.

The analog pins of the Arduino UNO control board are connected to the LDRs pin.

A better level of resolution may be obtained when receiving intensities via the analog pins. The pulse width modulation pins of the microcontroller are linked to two servo motors: the horizontal servo motor and the vertical servo motor. the tracking actuators as well.

The Legend Sheet	
R1	Top Left LDR
R2	Top Right LDR
R3	Bottom Left LDR
R4	Bottom Right LDR
S5	Vertical Servo
S6	Horizontal Servo
DC7	DC Motor
C8	Arduino UNO

ARDUINO UNO CONTROLLER



Figure 14. diagram of Arduino UNO

The complete procedure has been managed by an Arduino UNO microcontroller. It has fourteen pins for input and output. PWM, often known as pulse width modulation, is the exclusive focus of six of these pins. The Arduino UNO has been chosen as the prototype's optimal controller because to its simplicity of usage. The controller's job is to follow the Sun's movements and notify the actuators to rotate as necessary. The controller moves an external actuator to carry out the self-cleaning function in addition to watching the sun. There are 6 ADC input ports on the Arduino Uno board. Any one of them—or all of them—can serve as an analog voltage input. The 10-bit resolution of the Arduino Uno ADC allows for integer values between 0 and (2^{10}) 1023. Accordingly, it will translate input voltages of 0 to 5 volts into integer values of 0 to 1023. Accordingly, for each $(5/1024)$ 4.9 mV per unit. The default reference value for the uno ADC channels is 5V. As a result, any input channel can accept a maximum input voltage of 5V for ADC conversion. We have an instruction that allows us to adjust this reference value because certain sensors provide voltages between 0-2.5V, meaning that using a 5V reference results in less precision. Therefore, we have "analogReference" for adjusting the reference value.

By default, the board's ADC resolution is set to the maximum of 10 bits; however, this resolution can be adjusted using the instruction "analogReadResolution(bits);".

PIN DAGRAM:



Pin layout of ATmega328p is showed below:

(PCINT14/RESET PC6)	1	28	PC5 (ADC5/SCL/PCINT13)
(/CNT16/RXD) PD0	2	27	PC4 (ADC4/SDA/PCINT12)
(PCINT17/TXD) PD1	3	26	PC3 (ADC3/PCINT11)
(PCINT18/INT0) PD2	4	25	PC2 (ADC2/PCINT10)
(PCINT19/OC2B/INT1) PD3	5	24	PC1 (ADC1/PCINT9)
(PCINT20/XCK/T0) PD4	6	23	PC0 (ADC0/PCINT8)
VCC	7	22	GND
GND	8	21	AREF
(PCIN16/XTAL1/TOSC1) PB6	9	20	AVCC
(PCINT7/XTAL2/TOSC2) PB7	10	19	PB5 (SCK/PCINT5)
(PCIN121/OC0B/TI) PDS	11	18	PB4 (MISO/PCINT4)
(PCIN122/OC0A/AIN0) PD6	12	17	PB3 (MOSI/OU2A/PCINT3)
(PCINT23/AIN1) PD7	13	16	PB2 (SS/OK1B/PCIN12)
(PCINT0/CLKO/ICPL) PB0	14	15	PB1 (OC1A/PCINT1)

Fig15. pin diagram ATMEGA328P

An 8-bit, 32-kilobyte AVR microprocessor from ATMEL called the ATMEGA328P-PU:

Microcontroller It serves as the prototype's central component. We are use an ATMEGA328P in our prototype. It has a parallel slave port, universal synchronous asynchronous receiver transmitter, analog comparator, and an analog to digital converter.

SOLAR PANEL



6V and 100 mA are the specifications of the prototype solar panel. On the rotary actuator, the panel is fastened. On a solar panel, a variety of photovoltaic (solar) cells are arranged in a specific way. The photovoltaic cell's surface is exposed to sunlight, which converts solar energy into electrical power by creating an electrical potential across the terminals. The atom releases the absorbed energy when it causes the electrons to move from one energy level, or orbit, to another. 24V/330 W panels are often used for home purposes.

LDR (RESISTANCE SENSOR)

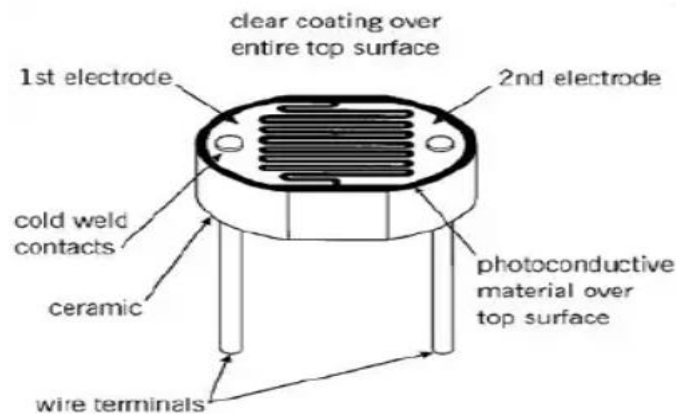

Figure 16. (LDR) *resistance sensor*

A group of resistors that depend on light make up the prototype's main part. An LDR resistor has a resistance that is inversely proportional to how much light is incident on its surface. Thus, it may be concluded that LDRs are more resistant to light during the day when light intensity is higher than at night when light intensity is lower. The LDRs are positioned on the edge of the panel and track the sun's movement. When using LDRs, the value is taken into account in order to get an accurate value when the reading values are combined.

Servo motor

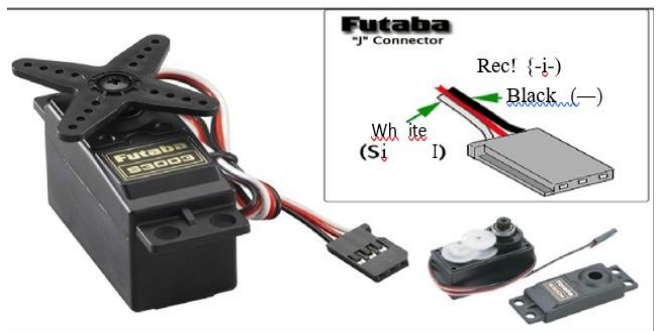
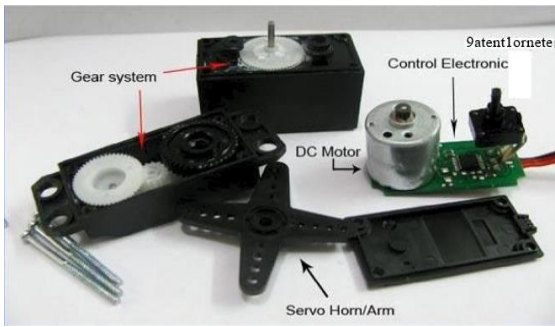

Figure 17. Motor, Servo

A tiny DC motor, feedback potentiometer, gearbox, motor drive electronic circuit, and electronic feedback control loop make up a DC servo motor. It resembles a typical DC motor in more or less every way.

The magnet is mounted inside the cylindrical frame that makes up the stator of the motor.

An armature coil is used in the construction of brushes to power the commutator. At the back of the shaft, a detector is positioned inside the rotor to measure rotation speed.

It is simple to create a controller using this construction because the torque is inversely proportional to the current passing through the armature.

A dual-axis sun tracker is being created in the prototype. Four LDRs have been integrated for the dual-axis tracker. Each LDR is positioned on one of the panel's four corners. Pitch movement signals are provided by one set of LDRs, and yaw movement signals are provided by the other set of LDRs. Due to the presence of two sets of sensors, the light intensity falling on LDRs has been compared using two separate function blocks. Early in the day, the set of LDRs measuring the strength of sunlight for the East-West arc encounters little resistance from the east-facing LDR. Westward-pointing LDR shows strong resistance grade. The signal comparison in the function block reveals that solar radiation is more common on the west coast.

SOLAR PANEL CONTROLLER

The second generation of solar charge control uses a regulator that can handle 10A of current at 12V or 24V of power. It has four different working modes—pure lighting control, lighting control & timing control, hand operation, and debug mode—as well as fully automatic operation and electrical protections. It also provides automatic lighting control function. This charge controller uses a PV array to detect day and night. It has timing settings for pathway lighting, street lights, parking lots, bus stops, and other things.



Features :

Reverse protection, overload protection, built-in open circuit and short circuit protection, built-in industrial microcontroller, one-key setting, auto memory function, digital display, fully 4-stage PWM charge management, and dual mosfet reverse current protection.

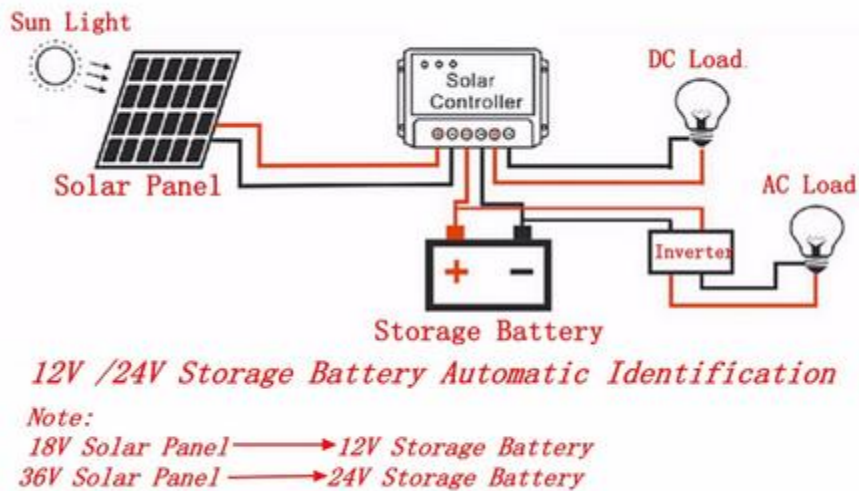

power Inverter

A power inverter is a piece of power electronics equipment or circuitry that transforms direct current (DC) into alternating current (AC). The specific device utilized determines the frequency of the AC generated. Inverters achieve the opposite of what rectifiers, which were formerly huge electromechanical machinery converting AC to DC, did.

The input voltage, output voltage, frequency, and total power handling are all determined by the circuitry or device's architecture. Instead of the inverter, which doesn't produce any energy, the power is provided by the DC source.

A power inverter can be entirely electronic or, in the case of a rotary device, it can mix mechanical effects with electronic circuitry. Static inverters do not use moving parts in the conversion process.

Power inverters are most typically utilized in electrical power. In applications where high currents and voltages are present, oscillators are circuits that carry out the same task for electronic signals, which normally have very low currents and

voltages. Electrical circuits called rectifiers do the reverse operation, turning AC to DC.



Figure 18 :power inverter .

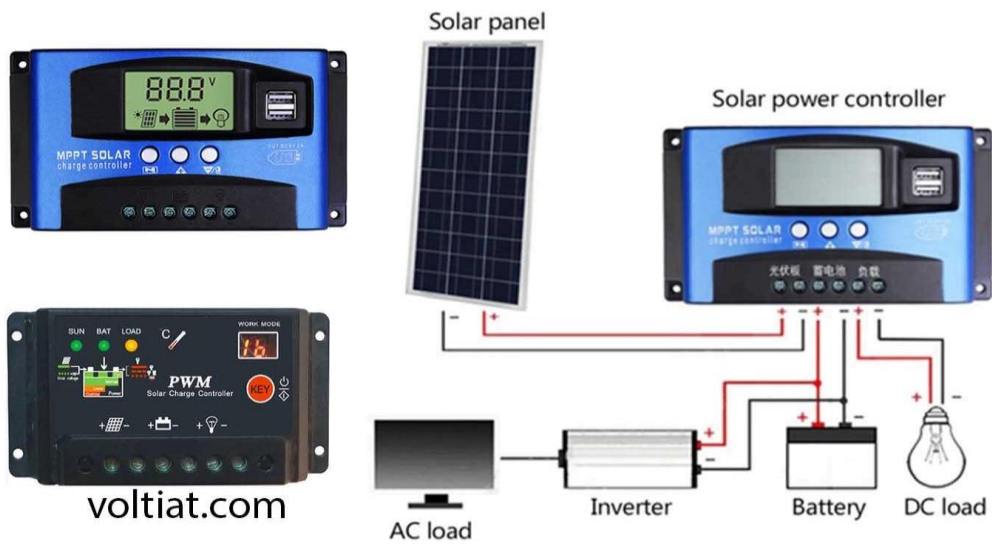

Figure 19 : Connection circuit diagram from the solar panel to the load .

BATTERY 12 VOLT

batteries 12 volt are a type of rechargeable battery commonly used to provide power in various applications.

batteries 12 volt are commonly used in cars, boats, solar power systems, and other electronic equipment.

In our project, we used it to store solar energy and then unload it into a load connected to an inverter.



Figure 20 : Battey 12 volt .

THE EMBEDDED SOFTWARE

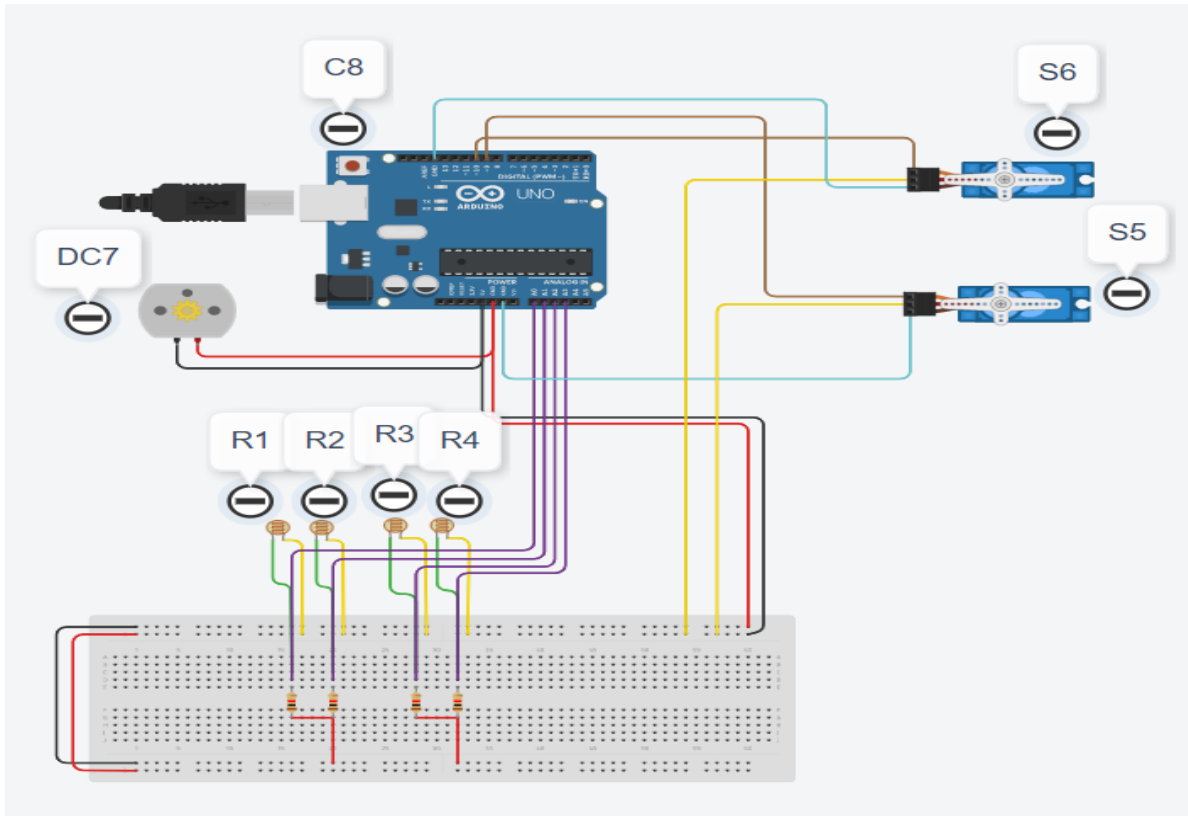

LDR	Position	Movement
LDR 1	Left and Bottom	DC Motor A (Bottom)-Anticlockwise
LDR 2	Right and Bottom	DC Motor B (Top)-Anticlockwise DC Motor A(Bottom)-Clockwise
LDR 3	Left and Top	DC Motor B (Top)-Clockwise DC Motor A (Bottom)-Anticlockwise
LDR 4	Right and Top	DC Motor B (Top)-Anticlockwise DC Motor A (Bottom)-Clockwise DC Motor B (Top)-Clockwise

For the purpose of operating and maintaining the solar tracker test bench, software will be embedded into the Arduino Uno hardware. The embedded program satisfies the following criteria:

1. Both manual and automated modes are available on the test bench. To make it possible to switch between the two modes, pin 12 is attached to a pushbutton.
2. The potentiometer may regulate servomotors from east to west for the left-right motor or from south to north for the up-down motor when the manual mode is engaged. The user may choose between the two motors—the left-right servo motor and the up-down servo motor—by adjusting the potentiometer thanks to a push button connected to pin 11.
3. The procedure shown in Fig. 4 will be applied if the automated mode is engaged. The latter makes use of the analog values that LDR sensors provide. The average results from two left LDRs and two right LDRs, for instance, are compared when assessing azimuth or vertical axis. The left-right servomotor of the solar tracker will move in that direction if the left pair of LDRs detects more light. The latter will keep turning until the differential reading is between [10, 10]. After the solar tracker is perpendicular to the sun, no more control is required; this range is utilized to stabilize the controller. On the other hand The solar tracker rotates in that direction, however, if the left-right servomotor is activated, until the differential reading falls between [10, 10], at which point the appropriate set of LDRs detects more light. In a similar manner, the elevation axis is constructed. It was also determined whether the average radiation between the four LDR sensors went below an adjusted and tested number (8, which is supplied when the radiation is null). In other words, the darkness is here. The solar tracker will have to move in this case to face the rising sun. To accomplish the sun rising position, for example, the left-right servomotor's left-right setting could be altered to 0 degrees, while the up-down servomotor's left-right setting could be changed to 30 degrees. This is made simple by the "servox.write(angle)" C method in the Arduino IDE.
4. The PV current and power must be calculated using the PV voltage that was obtained via analog pin A5. Then, MS Excel must be used to exhibit all of these data and the actual manner after they have been transferred to the computer via a USB cable.

Arduino Dual Axis Solar Tracker Project Programming :

```
#include <Servo.h>

#include <Servo.h>

// 180 horizontal MAX

Servo horizontal; // horizontal servo

int servoh = 180; // 90; // stand horizontal servo

int servoh Limit High = 180;

int servoh Limit Low = 65;

// 65 degrees MAX

Servo vertical; // vertical servo

int servo = 45; // 90; // stand vertical servo

int servo Limit High = 80;

int servo Limit Low = 15;

// LDR pin connections

//I name = analogpin;

int ldrIt = A0; //LDR top left - BOTTOM LEFT <--- BDG
```

```

int Idrrt = A2; //LDR top rigt - BOTTOM RIGHT

int idrid = A1; //LDR down left - TOP LEFT

int Idrrd = A3; //dr down rigt - TOP RIGHT

    void setup(){

        horizontal.attach(9);

        vertical.attach(10);

        horizontal.write(180);

        vertical.write(180);

        delay(2500);

        }

    void loop(){

        int it = analogRead(IdrIt); // top left

        int rt = analogRead(Idrrt); // top right

        int id = analogRead(idrid); // down left

        int rd = analogRead(Idrrd); // down right

int dtime = 10; int tol = 90; // dtime-diffirence time, tol-toleransi

        int avt = (it + rt) /2; // average value top

```

```

int avd = (id + rd) / 2; // average value down

int avi = (it + id) / 2; // average value left

int avr = (rt+ rd) / 2; // average value right

int dvert = avt - avd; // check the diffirence of up and down

int dhoriz = avi - avr; // check the diffirence og left and rigt

if (-1*tol > dvert || dvert > tol)
{
    if (avt > avd)
    {
        servov = ++servov;

        if (servov > servovLimitHigh)
        {servov = servovLimitHigh;}
    }

    else if (avt < avd)
    {servov= --servov;

        if (servov < servovLimitLow)
        {servov = servovLimitLow;}
    }
}

```

```
        }  
  
        vertical.write(servov);  
  
    }  
  
    if (-1*tol > dhoriz || dhoriz > tol) // check if the difference is in the tolerance else  
        change horizontal angle  
  
        {  
  
            if (avi>avr)  
  
                {  
  
                    servoh = --servoh;  
  
                    if (servoh < servohLimitLow)  
  
                        {  
  
                            servoh = servohLimitLow;  
  
                        }  
  
                }  
  
            else if (avi < avr)  
  
                {  
  
                    servoh = ++servoh;
```

```
if (servoh > servohLimitHigh)
```

```
{
```

```
servoh = servohLimitHigh;
```

```
}
```

```
}
```

```
else if (avi = avr)
```

```
{
```

```
delay(5000);
```

```
}
```

```
horizontal.write(servoh);
```

```
}
```

```
delay(dtime);
```

```
}
```

CHAPTER 4

ECONOMIC ANALYSIS OF PROJECT

ECONOMIC ANALYSIS OF PROJECT

4.1. INTRODUCTION:

Comparison of the productivity of panel anchoring structures:

The following table shows the differences between the productivity of the types of stabilization structures, on the basis that the moving system in two axes gives a productivity equal to 100% of the possible production.

Is it preferable to use a fixed or move system?

From the previous table, the following facts are clear:

installation type	electricity production of cells
Fixed	71.1%
Angle adjustment twice a year	75.2%
Angle adjustment 4 times a year	75.7%
moving in two axes	100%

- 1- The difference in the output of the fixed system, which depends on adjusting the tilt angles two or four times a year, is very weak and does not exceed 5% in the best case.
- 2- This difference is offset by an increase in installation costs and maintenance costs, because it needs seasonal follow-up to adjust the tilt angles. Some of the first time that the use of this method will give a much higher yield, but this misperception does not depend on any verified scientific data or figures.
- 3- The efficiency of the mobile system on two axes with a motor is more than the fixed system by about 28%, which is a good percentage that is not bad. In the recent past, the use of this system achieved a higher return than the use of the fixed system due to the high price of solar panels.

Efficiency study of the moving solar cell and the fixed solar cell and comparing the efficiency between the two cells: It was found that the solar cells in the mobile system are better than the solar cells in the stationary system, in relation to the possibility of changing the angle of the beam on which a large amount of solar radiation falls. We find that the efficiency of the mobile solar cells is better than the fixed solar cells.

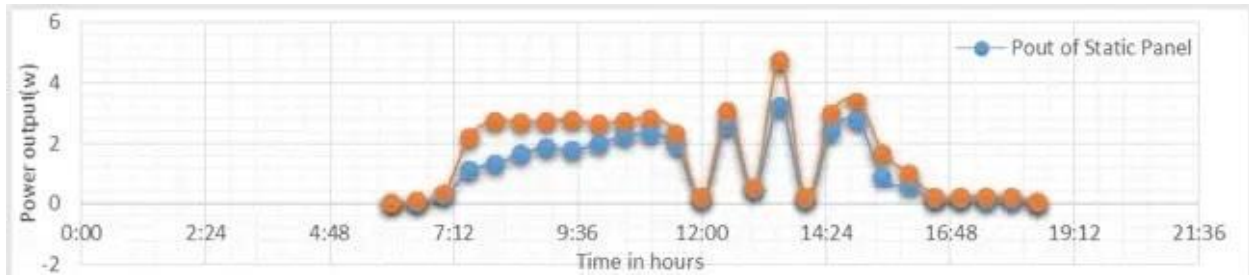

Figure 21 : Power comparison of a dual-axis PV panel with a static panel

TIME	Weather	Automatic Solar Tracking System			Static Solar System		
		Voltage(V)	Current(A)	Power(W)	Voltage(V)	Current(A)	Power(W)
6:00 AM	Cloudy	9.1	0	0	9	0	0
6:30 AM	Cloudy	9.83	0.008	0.07864	9.71	0	0
7:00 AM	Cloudy	11.58	0.03	0.3474	11.37	0.02	0.2274
7:30 AM	Sunny	11.6	0.19	2.204	11.23	0.1	1.123
8:00 AM	Sunny	12.36	0.22	2.7192	12.11	0.11	1.3321
8:30 AM	Sunny	12.11	0.22	2.6642	11.82	0.14	1.6548
9:00 AM	Sunny	11.89	0.23	2.7347	11.71	0.16	1.8736
9:30 AM	Sunny	12.01	0.23	2.7623	11.85	0.15	1.7775
10:00 AM	Sunny	11.93	0.22	2.6246	11.77	0.17	2.0009
10:30 AM	Sunny	11.87	0.23	2.7301	11.76	0.19	2.2344
11:00 AM	Sunny	11.67	0.24	2.8008	11.56	0.2	2.312
11:30 AM	Sunny	11.65	0.2	2.33	11.54	0.17	1.9618
12:00 PM	Cloudy	10.62	0.02	0.2124	10.23	0.01	0.1023
12:30 PM	Sunny	11.26	0.27	3.0402	11.21	0.23	2.5783
1:00 PM	Cloudy	10.91	0.05	0.5455	10.83	0.04	0.4332
1:30 PM	Sunny	12.04	0.31	4.7324	11.87	0.27	3.2049
2:00 PM	Cloudy	10.68	0.02	0.2136	10.61	0.01	0.1061
2:30 PM	Sunny	11.44	0.26	2.9744	11.33	0.21	2.3793
3:00 PM	Sunny	12.14	0.28	3.3992	11.92	0.23	2.7416
3:30 PM	Cloudy	11.15	0.15	1.6725	10.98	0.08	0.8784
4:00 PM	Cloudy	11.39	0.09	1.0251	11.16	0.05	0.558
4:30 PM	Cloudy	10.69	0.02	0.2138	10.55	0.01	0.1055
5:00 PM	Cloudy	10.61	0.02	0.2122	10.47	0.01	0.1047
5:30 PM	Cloudy	10.15	0.02	0.203	10.01	0.01	0.1001
6:00 PM	Cloudy	9.79	0.02	0.1958	9.57	0.01	0.0957
6:30 PM	Cloudy	8.75	0.003	0.02625	8.54	0	0
TOTAL	-----	289.22	3.551	42.66229	284.71	2.58	29.8856
AVERAGE				3.5552			2.4905

Figure22: Statistical Data for Voltage, Current and power for every half an hour in a Day.

PROJECT METHODOLOGY

This study's objective is to determine the project's costs, resource requirements, and chances of success over the short- and long-term.

As well as improving the work of solar cells and ensuring the success of the project objectives.

INTRODUCTION

The method that we followed in this project is the theoretical method and the applied method (applied method) using a hypothetical program, commensurate with the vocabulary of scientific research to calculate the productivity of solar cells in Tubas Turkish Governmental Hospital (Tubas City) and an experiment to study the relationship between temperature, efficiency, capacity of cells and solar radiation, and a hypothetical experiment To raise the efficiency of silicon solar cells by changing the angle of inclination of the cell. This project also belongs to the category of projects that aim to use mathematical modeling to derive and calculate values.

We will allocate our project (dual axis solar tracker) to feed the emergency department in this hospital.

Application of calculating the production of 1 kilowatt cells in Tubas Hospital:

As for calculating the productivity of solar cells based on the solar radiation in the city of Tubas, we used the program of the Al-Nasr Solar Company website and Global Solar ATLAS to calculate the solar radiation based on the coordinates shown in the image below:

According to the following steps:

- 1- We chose the location of the hospital on the map to calculate the cell productivity.**
- 2- The calculation is based on a moving system.**

For simplicity, the system losses are considered to be 20%, which is a standard percentage:

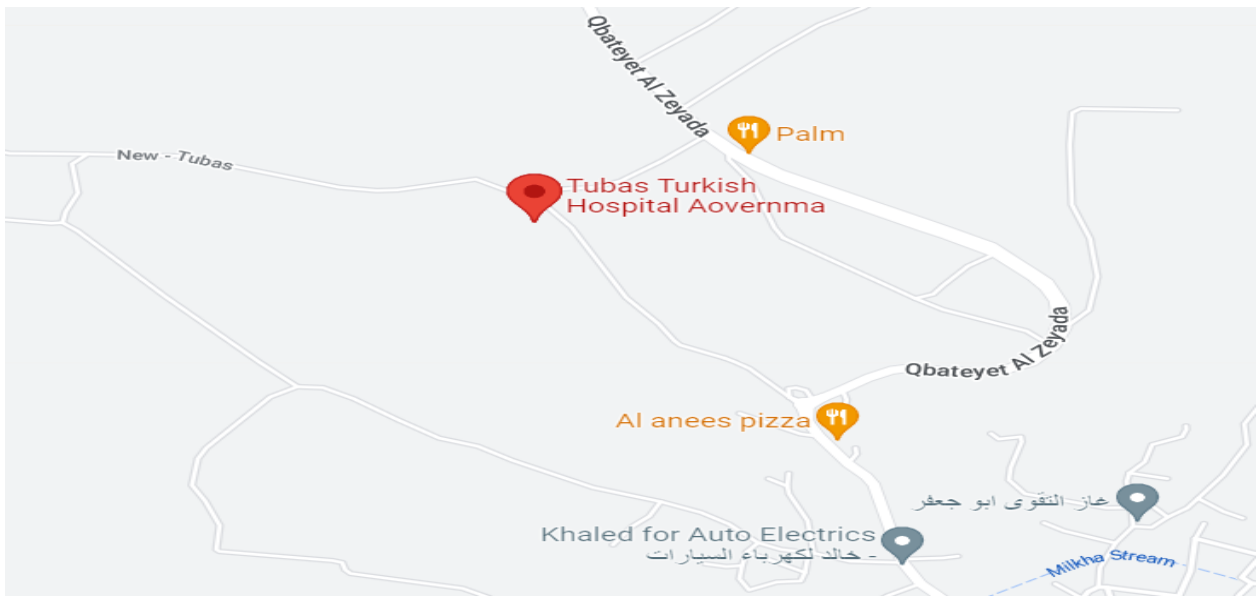

ELECTRICAL WIRING DIAGRAMS FOR HOSPITAL FLOORS

Figure (21) coordinates of the data Turkish Tubas Hospital.

Ground floor:

Light Plan:

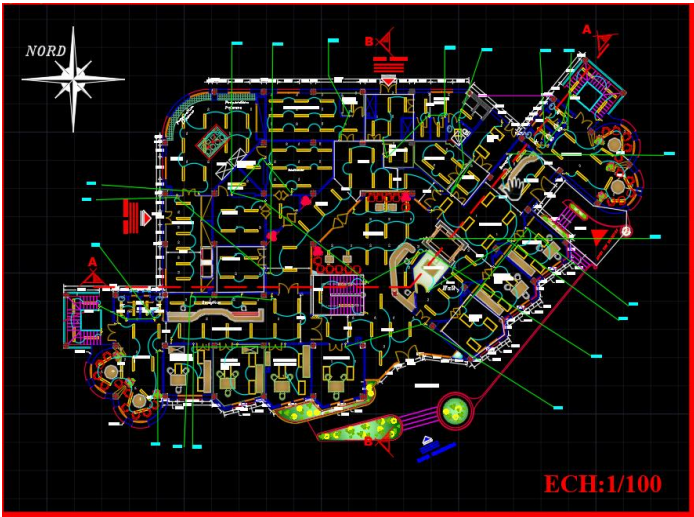

sockets plan:

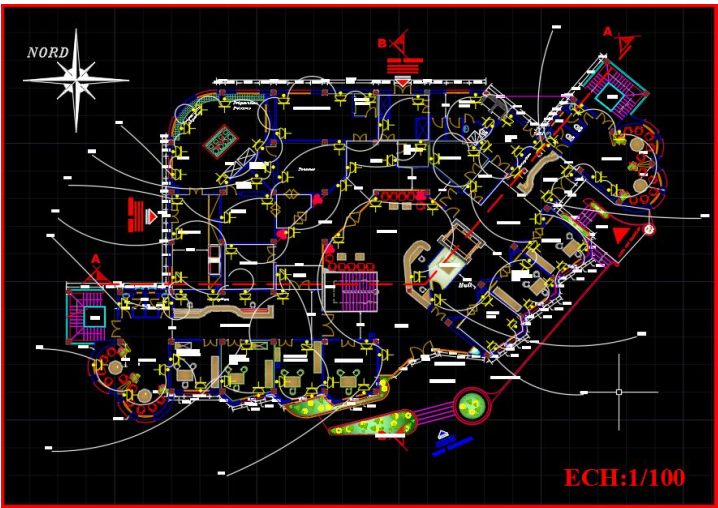

Smoke sensor & comp & telephone plan :



First floor:

**Light & sockets Plan
telephone**

Smoke sensor & comp &

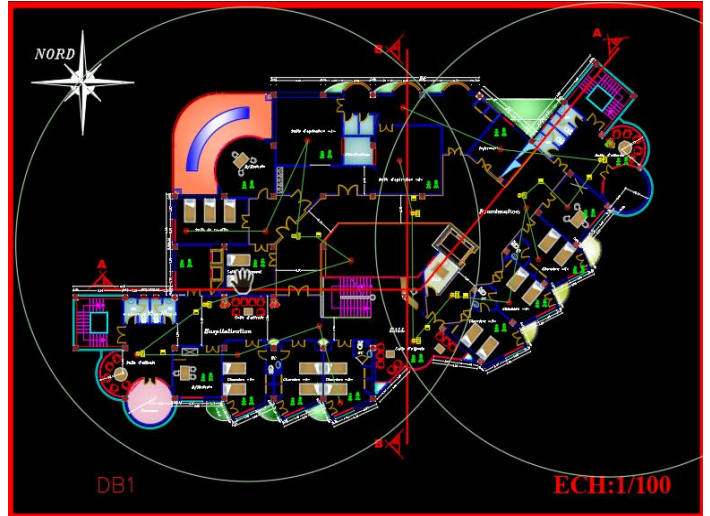
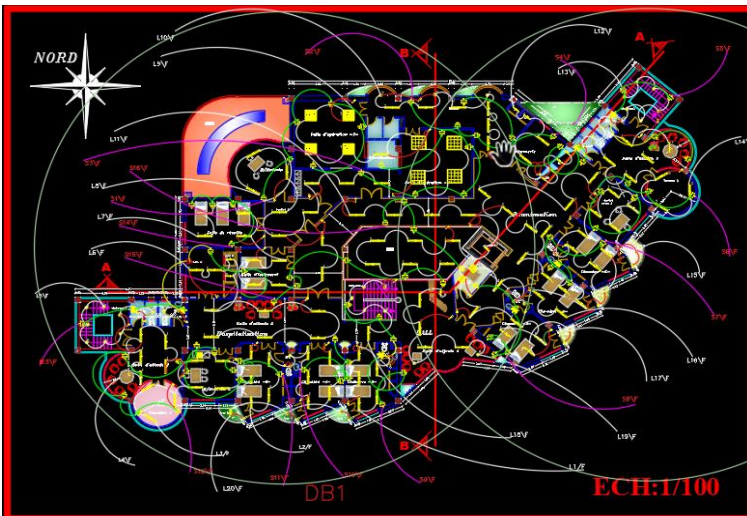

Second floor:

Light Plan :

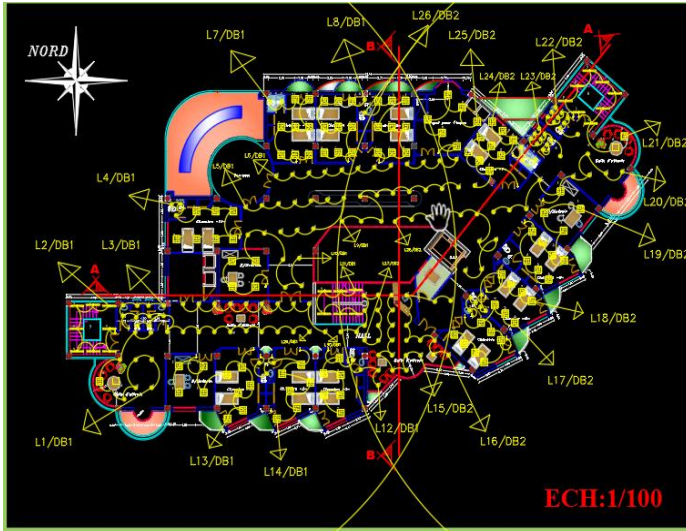

Sockets Plan :



Smoke sensor & comp & telephone plan:

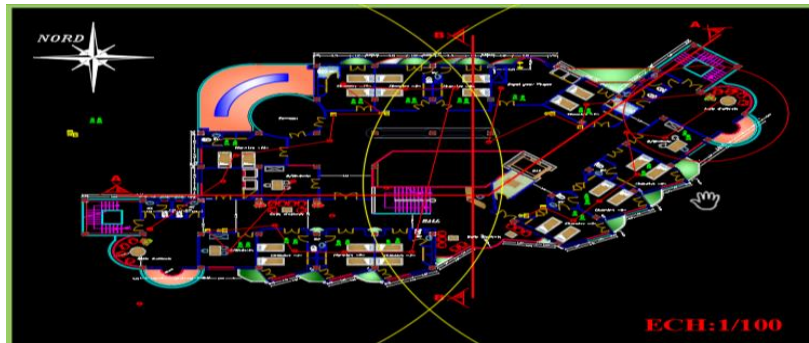

ANNUAL AVERAGES

Global slanted irradiation and total output of solar energy

4 MWh per day	5.946 KWh/m² per day U
--------------------------------	--

We chose Tubas City Hospital on the map based on the latitude and longitude coordinates as shown in Table (4.1):

Location and system size data

Unit of measurement	Value	Item
kWh/m ² per day	6.152	Daily solar radiation
north	35.357	Latitude
east	32.3836	Longitude
Kw	1	Solar panel capacity

Table (4.1) Location and System Size Data

We obtained the readings shown in the tables below during the summer and winter seasons during the day, month and year according to the best angles:

Production of solar panels at the best installation angle throughout the year:28

Monthly output in Mage watts	Daily output in kilowatts	Month
80.6	426.6	January
91.8	485.5	February
131.0	586.5	March
147.1	645.0	April
173.7	706.0	May
181.7	745.1	June
184.5	738.7	July
173.5	725.3	August
148.8	674.9	September
120.9	569.1	October
93.2	486.7	November
85.5	427.7	December

Table 4. Monthly generation of electricity [13]

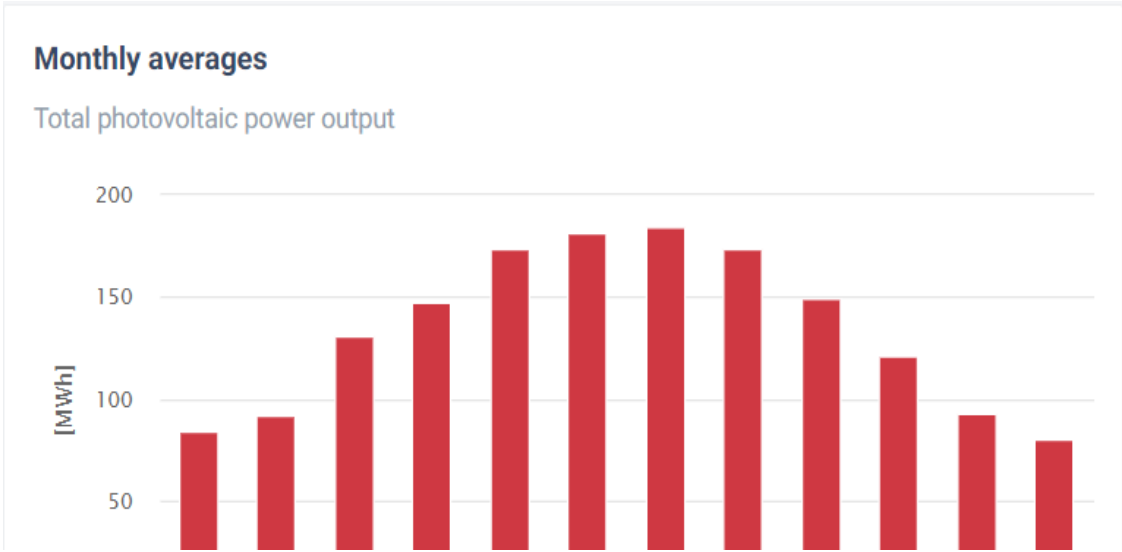

Average hourly profiles

Total photovoltaic power output [kWh]

	Jan	Feb	Mar	Apr	May	Jun	Jul	Aug	Sep	Oct	Nov	Dec
0 - 1												
1 - 2												
2 - 3												
3 - 4												
4 - 5					0	1	0					
5 - 6			0	9	46	57	40	16	5			
6 - 7	0	5	46	126	192	211	186	153	118	64	13	1
7 - 8	67	117	209	291	355	380	358	326	302	243	167	76
8 - 9	230	278	365	436	501	528	514	484	459	395	319	244
9 - 10	345	402	497	554	611	646	632	610	575	508	429	352
10 - 11	411	477	576	621	681	716	708	691	646	558	484	415
11 - 12	427	486	586	645	706	745	739	725	675	569	487	428
12 - 13	410	468	569	629	689	730	727	712	654	534	448	401
13 - 14	360	421	516	580	631	675	673	654	588	460	378	342
14 - 15	277	339	428	476	529	575	576	550	479	346	266	244
15 - 16	153	222	295	333	385	435	438	405	321	191	112	91
16 - 17	14	65	133	174	219	266	269	228	135	30	3	3
17 - 18		0	6	27	57	88	91	43	5			
18 - 19					1	2	2					
19 - 20												
20 - 21												
21 - 22												
22 - 23												
23 - 24												
Sum	2,695	3,279	4,227	4,902	5,603	6,056	5,953	5,598	4,962	3,899	3,105	2,596

Annual averages:

Direct normal irradiation (6.155 kWh/m per day).

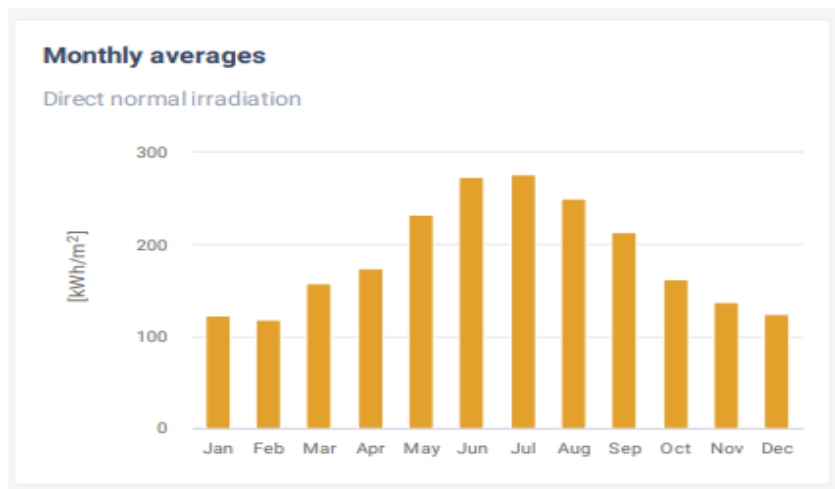

Average hourly profiles

Direct normal irradiation [Wh/m²]

	Jan	Feb	Mar	Apr	May	Jun	Jul	Aug	Sep	Oct	Nov	Dec
0 - 1												
1 - 2												
2 - 3												
3 - 4												
4 - 5					1	7	1					
5 - 6				29	215	325	253	92	32			
6 - 7	1	24	138	294	453	568	530	467	383	198	67	5
7 - 8	238	283	397	442	557	668	649	586	573	473	403	273
8 - 9	429	448	490	517	638	743	737	673	650	562	529	462
9 - 10	495	509	556	577	692	809	804	753	701	622	584	519
10 - 11	515	528	588	612	728	842	848	807	743	627	601	537
11 - 12	501	505	565	618	738	859	863	833	767	622	580	528
12 - 13	484	493	553	615	743	865	867	840	771	597	553	511
13 - 14	458	470	540	608	730	857	854	825	756	565	514	483
14 - 15	422	436	514	565	692	823	813	775	713	510	454	431
15 - 16	345	383	455	490	611	750	735	693	618	394	285	270
16 - 17	60	159	317	382	501	648	624	562	421	84	12	9
17 - 18				71	185	381	357	155				
18 - 19												
19 - 20												
20 - 21												
21 - 22												
22 - 23												
23 - 24												
Sum	3948	4237	5113	5822	7483	9146	8936	8059	7129	5254	4584	4028

ECONOMIC SYSTEM ANALYSIS

Another consideration for calculating the annual cost or savings from a PV system is the amount of electricity generated per month or year.

We will conduct an economic feasibility study for a biaxial solar cell project in Al-Turki Governmental Hospital in Tubas, Palestine:

Project Description:

A biaxial solar cell system is being installed on the roof of the Al-Turki Governmental Hospital in Tubas.

The system consists of 100 biaxial solar cell units to generate electricity.

Market analysis:

About 200 kWh of electricity is consumed in Al Turki Governmental Hospital every month.

The demand for electricity is expected to increase at a rate of 5% annually.

Cost analysis:

The installation cost of the project is estimated at \$150,000, including the costs of solar cells, tracking systems, and installation.

Annual maintenance costs are estimated at about \$3,000.

Revenue estimate:

The electricity generated from the project is sold at a price of \$0.15 per kWh.

The project is expected to produce about 120,000 kWh annually.

risk assessment:

The volatility of fuel prices and changing government legislation are potential risks for the project.

Various scenarios were evaluated, and it was found that the financial return of the project may be negatively affected in the event of a significant increase in maintenance costs.

Environmental assessment:

The project is expected to reduce carbon dioxide emissions by 90 tons annually, and contribute to preserving the environment in the city of Tubas and reducing the use of fossil fuels.

Financial analysis:

Estimating the expected recovery period for the project is about 4 years.

Calculating the expected financial return for the project based on the estimated costs and revenues.

To determine the viability of a project, compute the internal rate of return (IRR) and net present value (NPV).

NPV (Net Future Value):

Let's say your moving solar cash after deducting the 8% interest rate for 10 years is approximately \$50,000. This indicates that the project may be financially profitable.

IRR (Internal Rate of Return):

Let's imagine the project has a 12% internal rate of return. The project is lucrative and worth the investment if the internal rate of return exceeds the required rate of return, which in this case is 8%.

Payback Period:

We assume that the payback period is 4 years. This means that it will take about 4 years to recover the original capital investment from the expected profits.

Based on these approximate results, this project can be considered economically feasible and profitable in the specified time period (10 years in this example). However, other factors, such as potential risks and the legal and regulatory context, should also be taken into consideration and carefully evaluated to make a final decision about the feasibility and implementation of the project.

Write to a graduation project

Government support:

Analyzing the government support available for the solar energy project in Palestine, such as financial incentives, tax exemptions, and legal facilities.

Explore opportunities for cooperation with government agencies and other institutions to enhance project financing and provide financial and technical support.

Environmental and Social Sustainability:

Analyzing the positive environmental impact of the solar cell project at Al-Turki Governmental Hospital, such as reducing harmful emissions and relying on a renewable energy source.

Estimating the potential for obtaining environmental certifications, such as green carbon certifications, that can increase the value of the project and attract investors interested in sustainability.

Analyze potential social impacts of the project, such as improving the quality of healthcare and creating local job opportunities.

Training and awareness:

Developing training and awareness programs for the medical and technical staff in the hospital regarding solar energy and how to use and maintain it. This takes a financial import that costs about \$10,000 annually.

Providing training courses for local engineers and technicians to increase efficiency in the installation and maintenance of solar systems.

Energy saving analysis:

Analyzing projections of savings in electricity consumption thanks to the use of biaxial solar cells, which contributes to reducing energy bills for the hospital.

Estimating the financial value of those savings in the project payback period.

Incentives and financial facilities:

Explore incentives and financial facilities available from the local government or international institutions to encourage the use of solar energy and provide flexible financing for the project.

Safety and security analysis:

Evaluate the necessary precautions to ensure the safety of workers in the installation and maintenance process.

Consider the safety and security procedures required to deal with solar systems and protection from risks arising from electric current.

Environmental assessment:

Analyzing the impact of using solar cells on the environment around the hospital, including reducing carbon dioxide emissions and improving ambient air quality.

$$P[B.sub.t] = p[B.sub.t - 1] * (1 + i) + c[F.sub.t] * (1)$$

Table 1.p Details of the PV panels:

Panel cost	Watts per panel W (hp)	Weight per panel kg (lb)	Panel width m (ft)	Panel height m (ft)	Panel area [m.sup.2] ([ft.sup.2])	Nominal efficiency	Operating Temperature [degrees]C ([degrees]F)	Power degradation due to temperature / [degrees]C (% / [degrees]F)
\$5	197 (0.145)	14 (30.865)	0.66 (2.165)	1.499 (4.198)	0.989 (10.646)	12.80%	25 (77)	0.5% (0.278)

where **P[B.sub.t]**: is project balance for current year t; **P[B.sub.t-1]** : is the previous year project balance; **CCF**: is the current year cash flow; **i** : is interest rate .

Table 2. Annual savings:

Saving (\$)	Power from grid KWh (hp-hr)	Month
76.59	426.6	January

87.16	485.5	February
105.29	586.5	March
115.8	645.0	April
126.75	706.0	May
133.77	745.1	June
132.62	738.7	July
130.21	725.3	August
121.17	674.9	September
102.17	569.1	October
87.4	486.7	November
76.8	427.7	December

Saving = power / i → i= interest rate

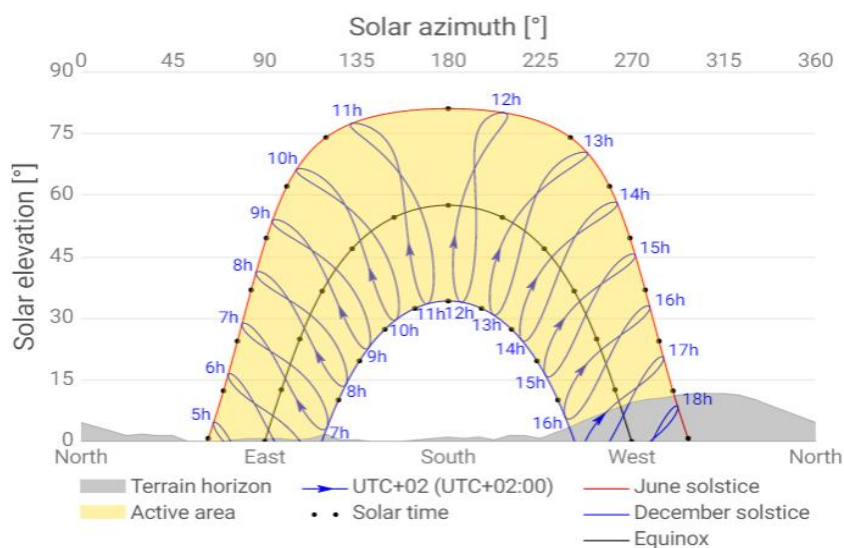

By conducting this integrated economic feasibility study, investors and the management of Al-Turki Governmental Hospital in Tubas can determine the feasibility of the project and anticipate the economic and environmental benefits of investing in a biaxial solar cell project in the hospital.

CONCLUSION

In this study, we adopted the methodology of the project to calculate the solar radiation in Tubas City Hospital, as well as the power calculations for all months of the year.

And also one of the contributions of this paper is to present the engineering economics analysis related to the project investment proposal IRR ($0.60\% < \text{market interest rate } 5.57\%$), NPV (less than zero). These results show that the project (i.e. the installation of a photoelectric biaxial tracking system) is not economically justified. However, installing this photovoltaic system may be a good decision for other important reasons such as academic, environmental, societal and political. The system is most useful for academic purposes through the solar system.

CHAPTER 5

Conclusion

Energy consumption per person is rising exponentially in the twenty-first century as we advance in technology, population, and economic development, yet our energy supplies, such as fossil fuels, are depleting quickly. In order to meet our energy needs, we must thus consider other strategies (such as the use of renewable energy sources).

In this project, Dual Axis Solar Tracker, we've created a demo model of a solar tracker to follow the light source's brightest point so that the solar panel's output voltage is at its highest there.

Dual-axis systems are substantially more effective in terms of electrical energy output as compared to fixed mount systems. In comparison to single axis solar trackers, dual axis solar trackers are more effective. One of the main contributions of this study is the development of a two-axis solar tracker prototype that forecasts the apparent location of the sun using data from four sensors. The two axis solar tracker hardware is in draft form designed using the AutoCAD software. Software like Sketch Up is also utilized to support this goal. This software allows for the creation of 3D prototype model designs. It aids in improving and improving the accuracy of the sketch. The circuit is made easier with the help of the Arduino and TinkerCAD, which saves a lot of time and effort. To improve the accuracy and thoroughness of this method, more research is required.

Every objective of this study has been achieved, including the initial one of using software to create a model of a dual axis solar tracker. The layout has been studied and put to the test . The second step is to program the Arduino's ATmega328p microcontroller so that it can work with an H-bridge to control the spinning of a DC motor. The five cases that make up the programming portion have been stated and examined. Thirdly, based on the amount of light the sensor is receiving, examine any voltage variations from the sensor (light dependent resistor, LDR). The result has been examined and plotted into a graph.

Then, in order to build a Dual axis solar tracker system for Tubas Turkish Hospital, we carried out an economic feasibility study. Once the investigation was completed, we interpreted the work's findings and conclusions.

RESULTS:

A working prototype of a sun tracker has been developed. The prototype is successfully running with the logic from the operation of individual system components. The solar panel moves in line with the movement of the motor to monitor sunlight from dawn to dusk. A solar tracker is built utilizing the creative technique of employing small sensors to act as self-adjusting light sensors and providing a variable indication of their relative angle to the sun by detecting their voltage output. The solar tracker proved effective in keeping a solar array at a sufficiently perpendicular angle to the sun by employing this technique.

CHAPTER 6

REFERENCES

REFERENCES

- [1] Solar Tracking Hardware and Software by *Gerro I Prinsloo*.
- [2] Design and Implementation of a Sun Tracker with a Dual-Axis Single Motor
“Jing-Min Wang and Chia-Llang Lu”.
- [3] Prasad, D. and Snow, M. (2005) Designing with Solar Power: A Source Book for Building Integrated Photovoltaic (BiPV). Earthscan, London, 23. [Citation Time(s):2].
- [4] Barsoum, N. (2011) Implementation of Dual-Axis Solar Tracking Pilot Project. Global Journal of Technology and Optimization (GJTO), 2, 49-56. [Citation Time(s):1].
- [5]. GLOBAL SOLAR ATLAS .info/detail .