



A 4 Switch Buck-Boost DC/DC Converter for Electric Vehicle

An-Najah National University

Faculty of Engineering

Electrical Engineering Department

By:

Dareen Nofal

Batool hanini

Mohammad Ghazzawi

Supervisor:

Dr. Kamel Subhi Saleh

Table of Contents

Abstract		6
Chapter 1: Introduction		
1.1	Problem Discussion	7
1.2	Aims and Objectives	8
1.2.1	Scope of the Work	8
Chapter2: Standards, Constraints and Earlier Coursework		
2.1	Standards	9
2.2	Constraints	9
2.3	Earlier Coursework	10
2.4	Issues and Challenges	10
2.4.1	Real-Time SOC and SOH Estimation	10
2.4.2	Optimal Charging Problem and Characterization	11
2.4.3	Battery Models BMS	11
2.4.4	Battery Charger and Discharging Issue	11
2.4.5	Safe and Efficient Operation Operations can be extended due to a loss of LIB capacity.	12
2.4.6	Aging and Memory Effect	12
2.4.7	Power Source and Consumption	12
Chapter3: Literature Review		
3.1	History	13
Chapter 4: Alternative Solutions		18
Chapter 5: Methodology		
5.1	H-Bridge	19
5.2	Buck Converter	19
5.3	Boost Converter	21
5.4	Functionality of the Four-Switch Buck-Boost Converter	22

5.5	Role and Function of the H-Bridge Configuration	23
5.6	Voltage and Current Controller Mechanism of Action	24
5.6.1	Voltage Controller	24
5.6.2	Current Controller	24
5.6.3	Integrated Control	25
5.6.4	Constant Current Phase	25
5.6.5	Transition Phase	25
5.6.6	Constant Voltage Phase	26
5.6.7	End of charge	26
5.6.8	Percentage of Battery Voltage at Switching Point	27
5.6.9	Practical Implications	27
5.6.10	Voltage Threshold	28
5.6.11	Current Threshold	28
5.6.12	Temperature Considerations	28
5.6.13	Battery Management System (BMS)	28
5.7	Design and Results	29
5.8	Simulation Results	33

Chapter 6: Hardware

6.1 hardware components

6.1.1	Li-ion Battery	36
6.1.2	3.6V Lithium Battery	37
6.1.3	Arduino Uno	37
6.1.4	H-Bridge	38
6.1.5	Current Sensor	39
6.1.6	Voltage Sensor	39
6.1.7	MG 6-MG-9 Sealed Battery	40

6.1.8	Oscilloscope	40
6.2	Hardware Design	
6.2.1	Hardware Implementation	41
6.2.2	Operating Principle	41
6.2.3	Power Stage: H-Bridge Configuration	42
6.2.4	Control and Sensing Stage (Arduino + Sensors)	42
6.2.5	Energy Sources” Batteries”	43
6.2.6	Real-Time Monitoring: Oscilloscope	43
6.3	Hardware Results	44
Chapter 7: Conclusion and Future Work		
7.1	Conclusion	
7.2	Future Work	
References		

Table of Figures

Chapter 3: Literature Review		
History		
3.1	Circuit diagram of an ideal buck regulator	13
3.2	Waveform of voltage and current of buck converter	14
3.3	Circuit diagram of Buck-Boost converter	14
3.4	Equivalent circuit of Buck-Boost converter	15
3.5	Waveform of Buck -Boost converter	16
Chapter 5: Methodology		
5.1	Schematic of an H-bridge.	18

5.2	Schematic of a buck-converter.	18
5.3	Duty Cycle Diagram	19
5.4	Schematic of a boost-converter	20
5.5	Four switch buck-boost modes	21
Simulink		
5.6	Whole system	28
5.7	H-Bridge	29
5.8	voltage controllers	30
5.9	Current controllers	30
5.10	PWM and Current and Voltage controllers	31
5.11	DC power source	31
Simulation results		
5.12	Output result	32
5.13	Reference voltage with battery voltage	33
5.14	After adding current controller	34
5.15	After adding voltage controller	35
Hardwer results		
6.3.1	PWM Output Signal from Arduino to L298N H-Bridge	44
6.3.2	Current sensor calibration	45
6.3.4	Closed loop condition	47
6.3.5	Drawing and values of current and voltage (closed loop status)	48
6.3.6	Open loop status	53
6.3.7	Drawing and values of current and voltage (open loop status)	54
Chapter 6: Hardware		
6.1	3.6V Lithium Battery	37
6.2	Arduino Uno	37
6.3	H-Bridge	38

6.4	Current Sensor	39
6.5	Voltage Sensor	39
6.6	MG 6-MG-9 Sealed Battery	40
6.61	Oscilloscope	40
6.62	Hardware Design	41

Abstract

The secret to increasing the use of sustainable energy is efficient energy storage. Designing a battery system that encompasses specific volume requirements offers a prolonged life cycle and exhibits rapid charge and discharge characteristics necessitates careful consideration. In this project, we used a technique to improve the battery of the Electric Vehicles (EVs) by controlling in charging voltage into battery by using a buck boost dc/dc converter. the buck boost converter is required as factors such as speed, ground clearance. can increase or decrease the charging voltage. Thus, this project consists an analyzed for input buck-boost converter (IBBC) and proposes charging of EV battery. IBBC small-signal model is derived and used to design a controller for four switches. And the project shows the Simulink model of the four switches buck boost converter that is applied in EV battery and the results of the simulation and performance of the IBBC and all of this is discussed.

Most DC/DC converters are used in applications where both VIN and VOUT are fixed or have a narrow range. However, there are applications where either VIN or VOUT, or both, have a very wide range. For example, the voltage of the battery in a battery charger has a wide range from minimum charge to full charge; thus, the DC/DC converter used in the charger needs to provide a wide output range.

Chapter 1: Introduction

Introduction

Problem Discussion

The main disadvantage is the limited driving range due to the limited capacity of the battery which cannot be usually recharged quickly. Since most of the cars in cities don't drive more than 50 km during a day and since this is easily possible for electric vehicles, they are the best vehicles which help to improve the environmental conditions in cities and their suburbs. The type of battery used in the project is lithium. The increased demand for LIB is a result of its availability and dependability. LIBs have alleviated environmental challenges and demonstrated considerable potential. Numerous technologies, such as portable devices, hybrid electric cars, mobile devices, laptops, and digital cameras, rely on their efficiency. Due to their high capacity, low open circuit voltage, low-volume expansion, and high absorption energy, LIBs are also used in thermal runaway modeling and detection compared to other batteries (Na/K/Ca). Compared to conventional batteries, LIB has 10 times longer lifespan and continues to function at 80% of its rated capacity after 2000 cycles and also the price of LIB technology is falling at a real-term rate of 8%–16% per year.

Despite the technology's potential, LIBs still have a number of disadvantages. High voltages can damage LIBs and cause them to overheat. Major issues have resulted from this. Additionally, as LIBs get older, they lose capacity and frequently break down. Their price, which is roughly 40% more expensive than Ni--Cd, is another obstacle preventing their wider use. Finally, although having a higher energy density than other battery types, LIBs still have an energy density around 100 times lower than gasoline with a 2- to 3-year lifespan following production.[2].

1.2 Aims and Objectives

1.2.1 Scope of the Work

The basic advantages of electric vehicles (EVs) are: (a) no emissions at the point of their operation, (b) very low emissions, if the energy is produced in normal power stations, (c) lower energy consumption compared to conventional cars, and (d) very low noise during operation.

A four-level DC/DC Buck Boost power converter is introduced. The primary application for this converter is to regulate the center capacitor voltage. The steady-state and average-value models for the proposed converter are developed and compared in simulation. The converter was constructed in the laboratory and verified on a four-level motor drive system. It was shown that the four-level DC/DC converter provides capacitor voltage balancing and allows higher output voltage utilization from the inverter.

control method based on model predictive current control is proposed for such converter with inherent smooth mode transfer capability without extra design on mode detection and transfer scheme. Modulator and mode detection are replaced by an optimization process through cost function. This largely simplifies the design and makes it easily implemented. Seamless transfer between buck and boost modes is achieved with many other system level benefits. Simulation and experimental results are provided to verify the effectiveness of proposed method for the four-switch buck–boost converter.

Simulation results of the suggested converter are presented in different operational conditions.

For simplicity of circuit analysis, the below assumptions are considered:

- All the capacitors are large enough. Hence, the voltage ripples of capacitors are neglected for obtaining the voltage gain in steady-state operation.
- The power switches are ideal, and the parasitic capacitor of the power switch is neglected.

Chapter2: Standards, Constraints and Earlier Coursework

2.1 Standards

There are many IEEE standards related to Buck–Boost DC/DC Converter. The IEEE Standard 2432, “Four-Switch Buck–Boost Converter Based on Model Predictive Control With Smooth Mode Transition Capability”, provides general guidelines and definitions [3],[4].

IEEE Standard 9131, “Harmonic Control in Electrical Power Systems”, provides recommended limits for efficient power management techniques that needed for longer battery life. And shown systems that required supply voltages to be both higher and lower than the battery voltage (e.g., power amplifier for CDMA applications), while supplying significant current, which is most efficiently generated by a noninverting buck-boost switching converter [5],[6].

2.2 Constraints

The electrical battery especially Lithium which Challenges LIBs have several features: high capacity, high power and energy density, high temperature tolerance and cyclic life, long duty cycle, fast charging, and less effective memory. However, there are some issues, so it is required to indicate appropriate solutions for safety excitabilities, recycling and environmental impacts, custom and expansive characteristics, and the discharging- and charging-period memory effect for a wide range of sequential uses. These issues are also applicable to other electrochemical batteries for EV applications. The following are summaries of the main problems. [7,8]

Real-Time SOC and SOH Estimation SOC estimation is challenging due to the highly non-linear properties of EVs

However, it has flaws like early SOC faults, current measurement and integration faults, and battery capacity uncertainties. Furthermore, the battery needs to rest; measuring open-circuit voltage is impossible in real-time. There is a technique for estimating parameter errors, voltage and current measurement errors, aging, and temperature.

2.3 Earlier Coursework

Some of the courses taken so far in this program have helped in provided basic important knowledge and understanding of the components and techniques used in this project. Below are some of the courses that helped complete this project:

- Power Electronics:** It helped us to construct the different circuits, such as buck-converter, boost-converter and others.
- Special Topics in Power:** It provided us with in-depth knowledge about buck-boost converters, and battery charging techniques that helped us in the design and optimization of our project.
- Control Systems:** it helped us understand and implement PI controllers to ensure stable operation in our project.
- Modeling of electrical engineering systems:** to simulate our project in the MATLAB.
- Microprocessors and Microcontrollers:** it improved our skills to program and connect our project with Arduino board.
- English for engineers:** it improved our skills to write a full integrated report.

2.4 Issues and Challenges

LIBs have several features: high capacity, high power and energy density, high temperature tolerance and cyclic life, long duty cycle, fast charging, and less effective memory. However, there are some issues, so it is required to indicate appropriate solutions for safety excitabilities, recycling and environmental impacts, custom and expansive characteristics, and the discharging- and charging-period memory effect for a wide range of sequential uses. These issues are also applicable to other electrochemical batteries for EV applications. The following are summaries of the main problems.[12]

2.4.1. Real-Time SOC and SOH Estimation

Estimating the State of Charge (SOC) in electric vehicles (EVs) presents significant challenges due to the highly non-linear characteristics of their batteries. Key issues include early SOC inaccuracies, errors in current measurement and integration, and uncertainties in battery capacity. Additionally, factors such as voltage and current measurement errors, aging effects, and temperature variations further complicate accurate SOC estimation. Although various methods have been developed to estimate the SOC and State of Health (SOH) of EV batteries, real-time estimation in practical applications remains a significant challenge. Developing a cost-effective Battery Management System (BMS) with minimal memory requirements and high processing

speed is particularly demanding. Current real-time SOH estimation methods often overlook minor variations in battery health, and model-based techniques have notable limitations, including inaccuracies in predicting health states. Addressing these challenges is critical for advancing the performance and reliability of EV battery systems. [13],[14].

2.4.2. Optimal Charging Problem and Characterization

The current charging technique takes a long time to charge an EV's batteries with a battery pack, which is less efficient and less safe. The CC trickle is the most common technique for charging methods. However, as it uses low currents, charging takes a longer time. Increasing the charging current reduces charging time but raises the OCV of streamers above the safe threshold and generates heat. There are significant drawbacks to traditional battery charging methods. Therefore, balancing the charging efficiency, heat, battery lifespan, and degradation is challenging.[15]

2.4.3. Battery Models BMS

BMS batteries are typically characterized using physical (equivalent, electrochemical) and data-driven (hybrid) techniques. Testing in different environments is impossible due to the need for precise conditions. Data-driven algorithms' performance and computational complexity highly depend on test data and training procedures. It has resulted in several clever techniques/algorithms [16,17].

2.4.4. Battery Charger and Discharging Issue

batteries are typically characterized using physical (equivalent, electrochemical) and data-driven (hybrid) techniques.

Another problem for BMS is the lack of universal battery chargers. Custom battery chargers tend to be more compact and intended for domestic use, leading to increased electrical clutter and environmental waste. As a result of the wide variety of batteries in use, battery charger designers must handle this issue. Working with damaged or old batteries necessitates using safe-discharge batteries, which can be dangerous. Batteries in brine produce hydrogen and oxygen gases that must be vented to avoid detonation. Using resistors to release batteries requires a low current to prevent overheating [18,19]

2.4.5. Safe and Efficient Operation Operations can be extended due to a loss of LIB capacity.

A serially connected battery that exceeds the V limit may cause a charging interruption to prevent overloading. Undercharged batteries have a shorter life span. Batteries lack a safe working range due to constantly changing internal and external factors [20]. This may cause significant concerns with cell reliability and stability. Furthermore, maintaining a proficient operational condition is difficult, especially for BMS peripheral control units, as several circumstances impact battery electrochemical properties.

2.4.6. Aging and Memory Effect

A battery ages due to internal resistance and capacitance fading. High temperatures also speed up the aging process. It is impossible to tell when a battery is getting old until it suddenly stops working. A model that considers cell aging factors is required to solve this problem. The memory effect occurs after repeated charge–discharge cycles: less memory capacity and possible cell imbalances [21,22].

2.4.7. Power Source and Consumption

Since EVs have no other means of generating electricity except batteries, the BMS must draw its power from the battery it is tasked with safeguarding and maintaining. As a result, the BMS becomes more challenging to design. When an automobile operates, idling, or charging, its BMS consumes power. For this reason, if the car is left uncharged for an extended period, the BMS must consume very little energy to prevent battery depletion. Even with well-known automobiles like Tesla, this issue is still fairly prevalent.

Chapter 3: Literature Review

In this chapter, the literature review of all the aspects related to converter in general and four switch buck boost dc/dc converter in specific are discussed.

3.1 History

In many industrial applications, it is required to convert a fixed-voltage dc source into a variable-voltage dc source. A dc-dc converter converts directly from dc to dc and is simply known as a dc converter [23]. A dc converter can be considered as dc equivalent to an ac transformer with a continuously turns ratio. Like a transformer, it can be used to step down or step up a dc voltage source. The dc-dc converters are widely used for traction motor control in electronic automobiles, they provide smooth acceleration control, high efficiency, and fast dynamic response. DC-DC converters can be used in regenerative braking of dc motors to return energy back into the supply than this feature results in energy savings for transportation systems with frequent stops [24]. DC converters are used in dc voltage regulators and also are used in conjunction with an inductor, to generate a dc current source, especially for the current source inverter.

Different Topologies

The dc converters can be used as switching mode regulators to convert a dc voltage, usually unregulated, to a regulated dc output voltage. The regulation is normally achieved by PWM at a fixed frequency and the switching driver is normally BJT, MOSFET, or IGBT. The power regulator can be inductor based, switch-mode power converter, a switch capacitor charge pump or a linear regulator. Each regulator has its own advantages and disadvantages, but it is the particular application requirements that determine which type of power regulator is best suited. There are topologies of switching-mode regulators like:

- Buck regulator
- Boost regulator
- Buck-boost regulator

This thesis paper focuses especially on buck, boost and buck-boost regulator topologies. The boost is one of the fundamental switch-mode power topologies. The other being is the buck regulator. From these two topologies, all other topologies switch-mode power supply topologies are derived.

THEORETICAL BACKGROUND

Buck Converter

A buck converter is a step-down DC/DC converter consisting primarily of inductor and two switches (generally a transistor switch and diode) for controlling inductor. It fluctuates between connection of induction to source voltage to mount up energy in inductor and then discharging the inductors energy to the load.

When the switch pictured above is closed (i.e., On-state), the voltage across the inductor is $V_L = V_i - V_o$. The current flowing through inductor linearly rises. The diode doesn't allow current to flow through it, since it is reverse-biased by voltage.

For Off case (i.e., when switch pictured above is opened), diode is forward biased and voltage is $V_L = -V_o$ (neglecting drop across diode) across inductor. The inductor current which was rising in ON case now decreases.

Ideal circuit analysis

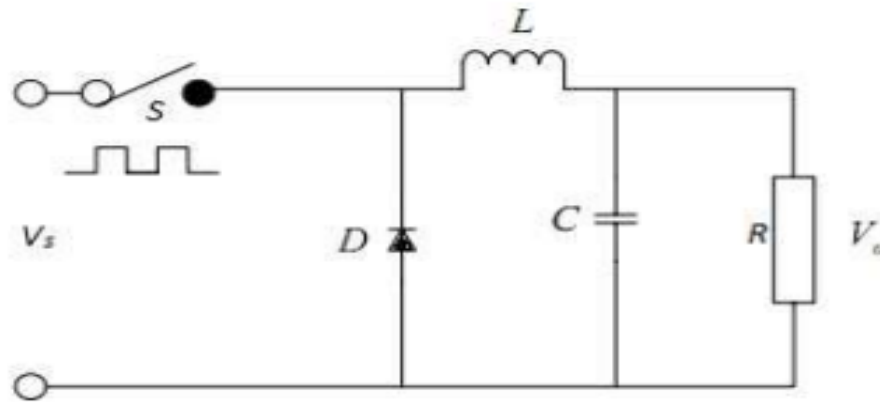

Figure1: Circuit diagram of an ideal buck regulator

In a buck converter, the average output V_a is less than the input voltage, V_s . The circuit diagram of a buck regulator has shown below and this is like a step-down converter.

The freewheeling diode D conducts due to energy stored in the inductor; and the inductor current continues to flow through inductor (L), capacitor (C), load and diode (D). The inductor current falls until transistor S is switched on again in the next

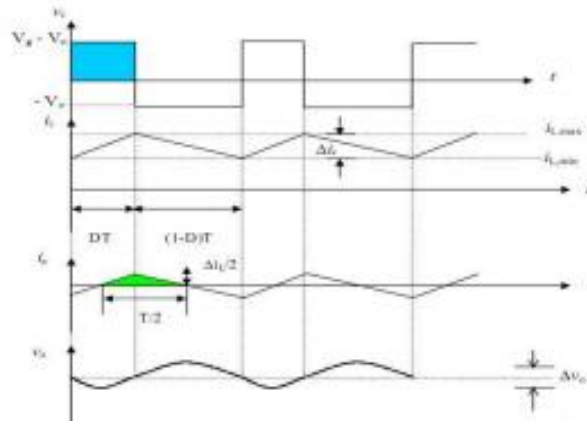

Figure2: Waveform of voltage and current of buck converter

The waveforms for voltage and current are shown in for continuous load current assuming that the current rises or falls linearly. For a constant current flow in the inductor L, it is assumed that the current rises and falls linearly. In practical circuits, the switch has a finite, nonlinear resistance. Its effect can generally be negligible in the most applications depending on the switching frequency, filter inductance, and capacitance, the inductor current could be discontinuous.

Boost Converter A boost converter (step-up converter), as its name suggest step up the input DC voltage value and provides at output. This converter contains mostly a diode, a transistor as switches and at least one energy storage element. Capacitors are usually added to output so as to perform the function of removing output voltage ripple and sometimes inductors are also combined with.

Its operation is generally of two separate states, • During the ON period, switch is made to close its contacts which results in increase of inductor current. • During the OFF period, switch is made to open and thus the only path for inductor current to flow through the fly-back diode and the parallel combination of capacitor and load. This enables capacitor to transfer energy gained by it during ON period.

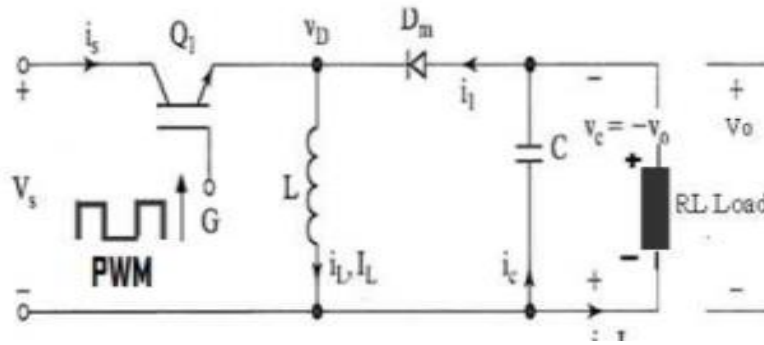

Figure 3: Circuit diagram of Buck-Boost converter

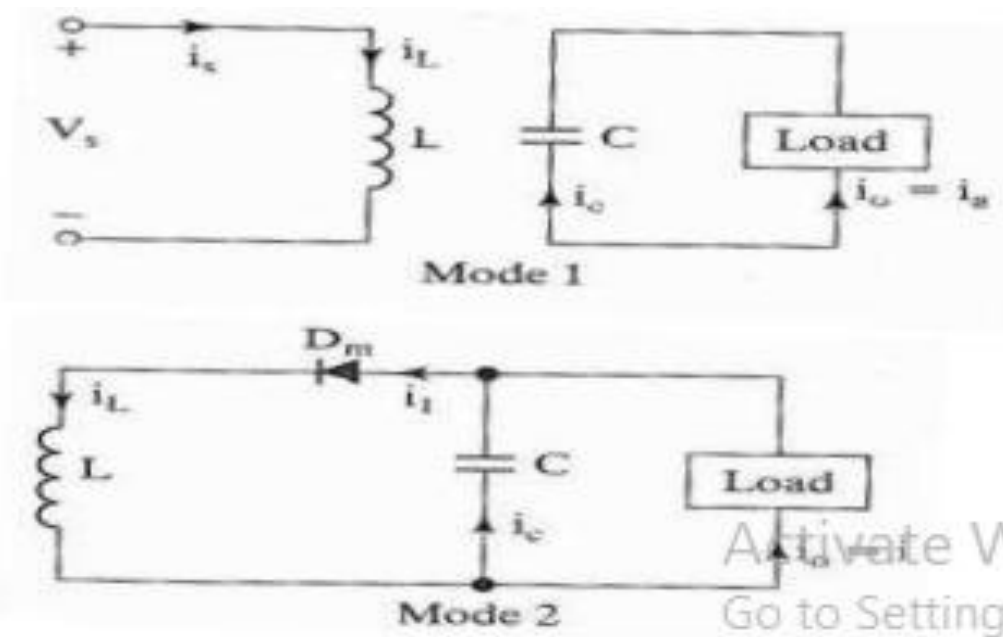

Figure 4: Equivalent circuit of Buck-Boost converter

The circuit operation divided into two modes. During mode 1, transistor Q1 is turned on and the diode Dm is reversed biased. The input current, which rises, flows through inductor L and transistor Q1. During mode 2, transistor Q1 is switched off and the current, which was flowing through inductor L, would flow through L, C, Dm, and the load. The energy stored in inductor L would be transferred to the load and inductor current would fall until transistor Q1 is switched on

again in the next cycle. The equivalent circuits for the modes are shown in figure 4. The waveforms for steady-state voltages and currents of the buck-boost regulator are shown in figure 5 for a continuous load current.

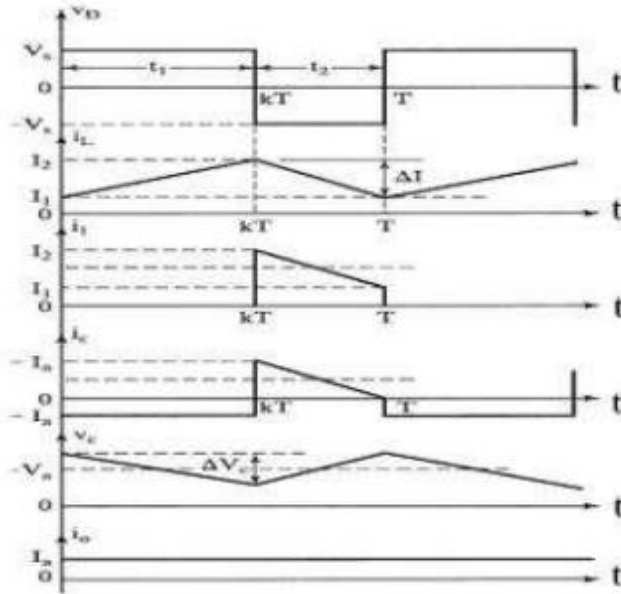

Figure 5: Wave form of Buck -Boost converter

DESIGN ANALYSIS OF DC-DC CONVERTERS

Performance Parameters There are quantities of vital performance parameters which decide the output characteristics of the dc-dc converters. These parameters should be well understood before designing an ideal dc-dc converter. [25]

Operating frequency

The operating frequency determines the performance of the switch. Switching frequency selection is normally determined by efficiency requirements. There is now a rising trend in research work and new power supply designs in increasing the switching frequencies. The higher is the switching frequency, the smaller the physical size and component value.

At higher frequencies the switching losses in the MOSFET increase, and therefore reduce the overall efficiency of the circuit.

At lower frequencies the required output capacitance and inductor size increases, and the volumetric efficiency of the supply degrades. The trade-off between size and efficiency has to be evaluated very carefully.

Chapter 4: Alternative Solutions

Electric vehicles (EVs) require efficient battery charging systems to optimize performance and extend battery life. Traditional buck-boost converters are commonly used in EV applications.[33]

Out of various topologies, the 4-switch Buck-Boost DC/DC converter would be most suitable for the application in EVs due to its simplicity, efficiency, and reliability compared to other conventional and alternative converters.[33]

In the conventional single-switch Buck-Boost converters, high-power applications are not suitable due to component stresses, low efficiency, and reliability problems. The 4-switch converter offers continuous input current and higher efficiency, which is more suitable for electric vehicle applications where the power demand varies.[34]

Composite DC-DC converters allow high efficiency but involve sophisticated control strategies and, accordingly, higher costs. The 4-switch converter represents a more straightforward design that provides reliable performance and does not require complex integrations.[34]

Resonant four-switch converters may face some problems concerning stability and control, while this 4-switch Buck-Boost converter offers flexibility in its ease of control, supporting both Buck and Boost operations without any extra complications.[35]

Because model predictive control-based converters need advanced algorithms, whereas in the case of a 4-switch converter, simpler control ensures smooth transitions and performance without adding complexity.[35]

The 4-switch converter has the potential for bidirectional power flow, which provides an enhancement in regenerative braking and energy recovery, improving the driving range. For over 91% efficiency, the usage of advanced materials like gallium nitride will minimize energy loss and further optimize EV performance.[33]

The 4-switch Buck-Boost DC/DC converter is efficient, reliable, and simple-those exact key factors that make this topology ideal for electric drives when compared to its alternatives.[33]

Chapter 5: Methodology

5.1 H-Bridge

H bridge are a critical component in automotive applications, particularly in electric vehicles (EVs), where they are used for efficient power conversion and management. These converters are essential for tasks such as battery charging, motor control, and stabilizing the vehicle's electrical system. This circuit used in many applications it's called H-Bridge because of the shape of the circuit which include four switching elements such as IGBTs, MOSFETs, BJT, etc. represent the letter "H" as shown in figure 5.1. [26]

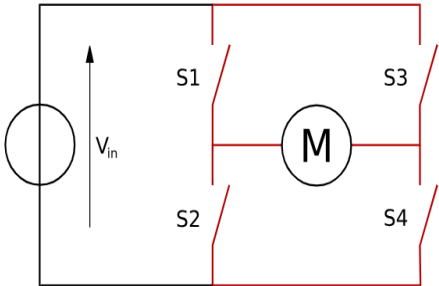

Figure 5.1: Schematic of an H-bridge [26].

5.2 Buck Converter

Buck converter is a device used to step down the DC voltage in power electronics, it's widely used in in various applications like power supplies, chargers and others. It's known of its simplicity, reliability and effectiveness. [27]

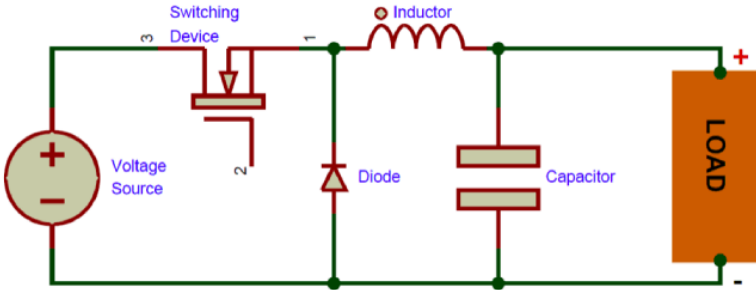

Figure 5.2: Schematic of a buck-converter [30].

The structure of buck converter consists of a switching device, inductor, capacitor and a diode as shown in figure 5.2. while operating the switching devices turns off and on intermittently, so when the switch is closed the energy stores in the inductor, and when the switch is open the energy in the inductor will discharge in the load. the diode used to make sure there is no reverse current flow and the capacitor to make the output voltage smoother.[27]

The opening and closing operation of the switch happened according to the duty cycle (D) so it's the ratio between the on-state time (T_{on}) and the total time ($T_{on} + T_{off}$)

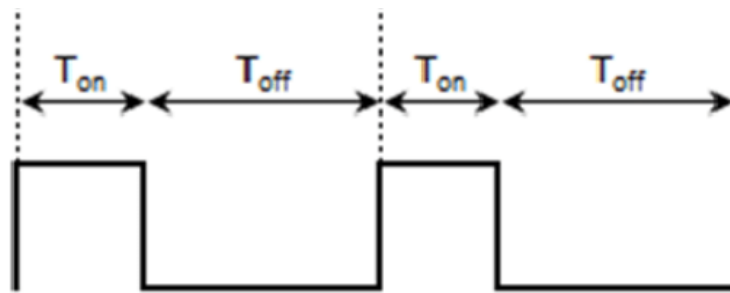

Figure 5.3: Duty Cycle Diagram [26]

$$\text{So } D = \frac{T_{on}}{T} \quad (5.1)$$

This parameter used to determine the output voltage of the buck converter which equals:

$$V_{out} = D * V_{in} \quad (5.2)$$

To design a buck converter, it's needed to choose the right values of the capacity of the capacitor (C) and the inductance of the inductor (L), which are given by these equations:

$$L = (V_{in} - V_o) * D * \frac{T}{\Delta i} \quad (5.3)$$

$$C = \frac{T * \Delta i}{8 * \Delta V_o} \quad (5.4)$$

Where Δi is the difference between $i_{on\ state}$ and $i_{off\ state}$ and ΔV_o is the difference between max and min value of voltage at steady state.[27]

5.3 Boost Converter

Boost converters are the opposite of buck ones, they step up the voltage, so they boost low DC voltage to higher voltages. They used in many applications like electric vehicles, LED drivers and others.[27]

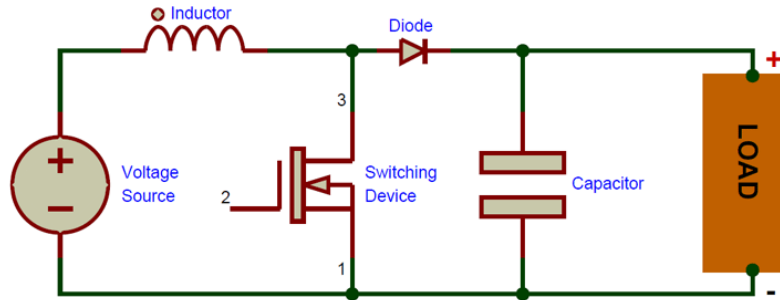

Figure 5.4: Schematic of a boost-converter [30]

The boost converter consists of a switching device to turn on and off while operating, and inductor so when the switch is closed the energy will store in it and when the switch is open it will discharge the energy, and a diode so the energy will only flow to the load, and the capacitor is used to make the output signal smoother. [27]

As mentioned before the opening and closing operation happened according to the duty cycle (D).

As shown in figure:
$$D = \frac{T_{on}}{T} \quad (5.6)$$

And the output voltage (V_o):
$$V_o = \frac{V_{in}}{1-D} \quad (5.7)$$

To design a boost converter, it's needed to choose the right values of the capacity of the capacitor (C) and the inductance of the inductor (L), which are given by these equations:

$$L = \frac{V_S * D * T}{\Delta i} \quad (5.8)$$

$$C = \frac{D * T * V_o}{R * \Delta V_o} \quad (5.9)$$

Where Δi is the difference between $i_{on\ state}$ and $i_{off\ state}$ and ΔV_o is the difference between max and min value of voltage at steady state[27]

5.4 Functionality of the Four-Switch Buck-Boost Converter

Bidirectional Power Flow: The converter has the ability to change the direction of power flow and thus provides the possibility of charging the battery as well as getting power from the battery and feeding it back either to the vehicle or back to the grid. This is of particular importance when energy resulting from regenerative braking should be stored or when, in any case, excess power can be fed back into the grid.[33]

Voltage Regulation: This is capable of both buck and boost mode operation. Operating in a buck mode, it steps down from higher input voltage to a lower output voltage; similarly, in the boost mode, it performs the stepping up of voltage from the lower input to higher output. This is of paramount importance for maintaining the optimum charge in the battery and facilitating the proper work of different vehicle electronics requiring various voltages.[34]

The below diagram shows the four different modes of operation.

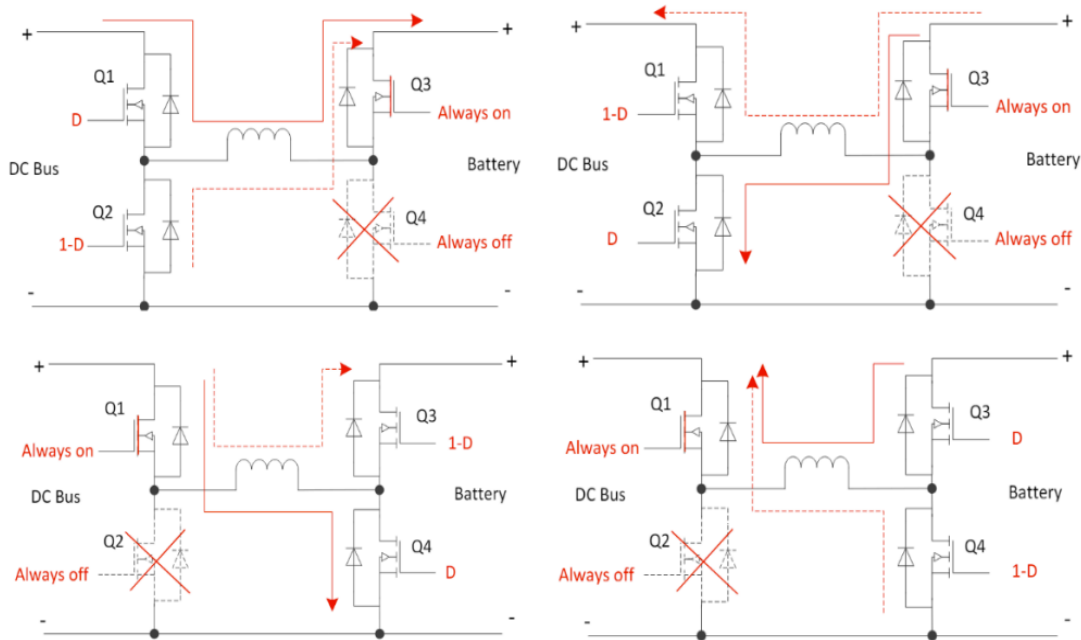

Figure 5.5. Four switch buck-boost modes.

Starting with the top left diagram, the input voltage from the DC bus is being stepped down meaning we are in buck mode. Q1 acts as the switch while Q2 emulates the diode of a normal buck converter, operating at a duty cycle of $1-D$. In the bottom left diagram, the voltage level is being boosted with power still flowing to the right. Q3 acts as the diode of a normal boost converter with Q4 being the switch. The top right is boosting the voltage but this time power is flowing right to left and the bottom right diagram is bucking in the same direction. Compared to the two-switch buck-boost shown below, the four switch also allows for greater efficiency with less losses. This greater efficiency is due to the fact that the forward voltage drop of the two diodes, V_F , is oftentimes much greater than the voltage across the switch V_{SR} . For example, V_F is typically about 0.6V to 0.7V

5.5 Role and Function of the H-Bridge Configuration

The H-bridge in the four-switch buck boost converter mainly provides the route through which current can flow in different paths to have a change in the direction of power flow and changeover between buck and boost modes. Basically, an H-bridge consists of four switches-transistors or MOSFETS-arranged in a square. By opening and closing these switches in different configurations, the direction and type of voltage and current supplied to the load can be controlled.[31]

- 1) **Switching Operation:** A switch is located at every corner of an H-bridge. These switches open and close in various combinations to change the polarity of the voltage applied to the load-a very important aspect of bidirectional power conversion.
- 2) **Selection of Mode:** The converter can be buck or boost mode, depending on which of the switches is closed. The input voltage will be either bucked or boosted:
Buck Mode: Two diagonally opposite switches close to form a path of current flow that generates lower voltage output.
Boost Mode: Different diagonally opposite switches are closed for a higher voltage.
- 3) **Efficiency and Control:** The use of the H-bridge allows for finer control of voltage and current, increasing efficiency in power transfer. This is extremely vital in terms of battery longevity and health, where the smooth transitions between charging and discharging modes can only be effectively made by an H-bridge setup.[31]

The H-bridge configuration in the four-switch buck-boost converter plays a pivotal role in the execution of its function, controlling power flow and voltage levels with maximum efficiency. Such capabilities form the backbone of modern electric vehicles since strong, flexible systems that can handle various diverse power demands and sources are necessary in automotive applications.

Voltage and current controllers, in the context of power electronics, use some advanced electronic mode of operation. For instance, in a DC/DC converter system for electric drive vehicles, the controllers ensure stability and efficiency in the power conversion processes.

Herein is how each controller operates:

5.6.1 Voltage Controller

Voltage controllers should provide an output voltage independent of variations either in load or input voltage. The principal methodology utilized by voltage controllers for their operation is a feedback mechanism that works incessantly to adjust the operation of a converter based on the deviation of a set voltage level.[34]

Key Components and Actions:

- 1) **Sensing:** Converter output voltage is sensed and fed back to the controller continuously.
- 2) **Comparators:** The sensed voltage is compared with a reference voltage or the desired output voltage.
- 3) **Error Signal:** Deviation of the actual output and the reference voltage is estimated, i.e., an error signal.
- 4) **Control Algorithm:** This takes the error signal through a control algorithm, which calculates the adjustment of control inputs - gate signals to the switches in the H-bridge to minimize the error.
- 5) **Adjustment:** The controller changes the duty cycle of the PWM signal driving the switches in the converter. This change in duty cycle, in turn, changes the average voltage and power flowing to the load to correct deviations from the setpoint.[34]

This dynamic adjustment process is continuous, therefore enabling the system to respond in real time to changes in load or input conditions, hence stabilizing the output voltage.

5.6.2 Current Controller

The current controllers regulate the current through the converter to the components and battery for protection against overcurrent conditions that may cause damage or reduce efficiency.[34]

Major Components and Their Operation:

- 1) **Current Measurement:** The current flowing through the converter is measured using current sensors. This measurement is important for real-time monitoring and control.
- 2) **Set Current Level:** The system is programmed with a maximum current level based on the safety and operational parameters of the circuit and battery.
- 3) **Comparison and Error Computation:** Here also, as in voltage control, the measured current is compared against the set current level to develop an error signal, if any.
- 4) **Control Logic:** The error signal will be processed through a control algorithm, which will calculate the exact adjustment that should be used to keep the current within desirable limits in the converter.

Modulation of Switches: The converter switches are operated on-the-fly by adjusting either the timing or frequency of the PWM signals to control the magnitude of the current. It could be a change in the duration of conduction in each switching cycle or the alteration of the frequency of switching to control the amount of energy transferred per unit time.[34]

5.6.3 Integrated Control

Most of the modern systems nowadays incorporate voltage and current controllers for better performance. Consider a buck-boost converter:

If there is high load demand, then the current controller may want to keep the current within a safe limit while the voltage controller adjusts the voltage accordingly to prevent dips that may affect the performance of the devices.[34]

Variable input conditions: Voltage controller regulates the output voltage at a constant value; current controller adjusts the flow to adapt the variation of input voltage or the condition of batteries.

These controllers are basic to efficiency, safety, and reliability for electric vehicle power electronic systems that manage batteries, enhance vehicle performance, and improve overall vehicle safety.

Current and voltage are the two major factors to be managed in the process of charging electric vehicles for safety, efficiency, and battery longevity. Most battery charging technologies adopt the strategy of prioritizing current control before voltage control. What is called Constant Current/Constant Voltage charging has been developed to optimize this process of charging while protecting the battery. [34]

Here's how this approach typically works:

5.6.4 Constant Current Phase

- 1) Initial Charge: As the battery is in a lower state of charge, it can safely absorb the higher current without any internal damage. Thus, the charger provides a constant current at its maximum value as the battery specifications allow. This is the fastest part of the entire charging process.
- 2) Existing Control: The current controller actively controls the charging current throughout this phase so that the latter does not rise above a predefined safe limit. Naturally, the voltage across the battery increases due to its time-varying charge state, but is still lower than its maximum rated voltage.[34]

5.6.5 Transition Phase

Approaching the voltage limit: During charging of the battery, its voltage will approach the upper bound voltage limit. Overvoltage needs to be avoided at this point as it might prove

harmful to the well-being of the battery.[34]

5.6.6 Constant Voltage Phase

- 1) Voltage Regulation: While the voltage is reached at its maximum safe limit, the charger switches over from constant current mode to a constant voltage. In this phase, the charger provides a constant voltage, drawing less current when the battery reaches its full charge.
- 2) Voltage Control: The voltage controller now becomes dominant, delicately controlling the voltage to maintain it at a pre-set level. Since the internal resistance of the battery increases with its state of charge, the current required to sustain the voltage decreases.
- 3) Decreasing Current: The charger now reduces the current in a controlled manner to avoid overcharging, which can reduce the life of the battery and lead to safety issues like overheating or thermal runaway.[34]

5.6.7 End of charge

Current Drops Off: The current is usually taken to be off when the current drops down to a fraction of the nominal charge current. This infers that the battery is full and maintains the voltage with a small flow of current to prevent overcharge.[34]

Why This Order?

- Battery Health: The initial stage of charging at constant current maximizes the speed of charging without overcoming the chemical capabilities of the battery, hence avoiding stress and heat buildup.
- Efficiency and Safety: It ensures, by switching to a constant voltage mode near full capacity, that the battery reaches its full charge without suffering damagingly high voltage levels.
- Optimized Charging: This method provides the most effective route to a quicker and safer charge of the battery with an extended operational life-span by avoiding extreme conditions

The CC/CV charging protocol is normally controlled by a highly sophisticated BMS within EVs, which is in charge of monitoring voltage, current, temperature, and health status for dynamic adjustments of the charging parameters. In such a way, it will ensure optimal charging with respect to its condition and external factors for much better performance and longevity.

The wider context refers to the switching point as the point where, during the charging of an electric vehicle battery, the charger switches from constant current to constant voltage. This is determined by the attainment of a threshold by the voltage of the battery, which is dictated by the chemistry of the cells that make up the battery and its maximum safe charging voltage.[34]

5.6.8 Percentage of Battery Voltage at Switching Point

- 1) Threshold of Battery Voltage: Common in most EVs, most lithium-ion batteries have about 4.2 volts per cell at full charge. This is the voltage setting near which the controller switches the CC to CV.
- 2) Percentage of Voltage: This is usually close to maximum capacity voltage.[34]
To express the same as a percentage:

Nominal vs. Maximum Voltage: A lithium-ion cell has a nominal voltage about 3.6 to 3.7 volts and a maximum voltage of about 4.2 volts. The switch to constant voltage charging occurs at nearly 100% of the maximum voltage but might be around 90-95 % of the fully charged voltage if considering the voltage under load or operational conditions at full charge.

Calculation Example:

If we consider a normal EV battery cell, which has a nominal voltage of 3.7 volts with a maximum charge voltage of 4.2 volts, then during charging it reaches a point of 4.2 volts, the switching point to the CV phase, at 100% of the maximum charge voltage.

If we refer to nominal voltage and go by the curve of charge, the upper limit of the charge can well be considered at 4.2 volts.

5.6.9 Practical Implications

- Safety and Efficiency: The CV phase begins at this point to avoid overcharging the battery, which can cause damage and reduce the battery's lifespan. Maintaining the voltage at this level while reducing the current helps to fully saturate the battery's charge capacity without exceeding voltage limits.
- Battery management: This process balances the battery cells and permits every cell to achieve a full charge without going into overvoltage conditions, hence taking care of the overall health and longevity of the battery.

In all, transition from current control to voltage control in EV battery charging occurs when the battery voltage reaches 100% of its designed maximum charging voltage per cell. This will ensure safe and efficient charging of the battery while maximizing its lifespan and performance.[34]

The charging threshold of a battery, especially in EVs, includes voltage and current limits, which are related to the chemistry, capacity, and design specifications of the battery. In general, the following thresholds are considered:

5.6.10 Voltage Threshold

Lithium-ion Batteries: Most electric vehicles have lithium-ion batteries. For these batteries, the typical end-of-charge voltage per cell is around 4.1 to 4.2 volts. Since EV batteries are typically made of hundreds of cells connected in series and sometimes in parallel, the overall charging voltage sums up the voltages across all the series-connected cells. For instance, a series connection of 100 cells for a battery pack would take a threshold charge voltage roughly around 410 to 420 volts at full charge.

Other Chemistries: Most other battery chemistries, such as nickel-metal hydride or lead-acid, have other voltage limits. For example, most lead-acid batteries operate at a charge voltage of roughly 2.4 to 2.5 volts per cell.[34]

5.6.11 Current Threshold

Constant Current Region: For most batteries, the constant current region threshold is often determined by the capacity of a battery and its C-rating. C-rate defines how fast the battery is charged or discharged compared to its maximum capacity. The charge at a 1C rate, for example, can indicate that the battery charges in such a way that it could reach full capacity in one hour. For EVs, typical C-rates during the constant current phase range from 0.5C to 1C or higher, depending on the battery management system and thermal management capabilities.

Charging Current at End of Charge: When the voltage threshold of the battery is attained, it enters into the constant voltage phase whereby the current tapers off gradually. Charging is often said to be complete when current levels fall to around 0.05C or lower since the battery is close to being fully charged and further charging will only trickle charge in an attempt to maintain the voltage without increasing the state of charge any further.[34]

5.6.12 Temperature Considerations

Temperature Limits: The other important factor that affects battery charging is temperature limits. A lithium-ion battery can be best charged, for example, within a temperature range of approximately 0°C to 45°C. Charging within this temperature will ensure higher efficiency, life span, and safety.[34]

5.6.13 Battery Management System (BMS)

Functionality of BMS: Regarding EV applications, the BMS mainly handles the monitoring and controls around these thresholds. They don't let the voltage increase further than

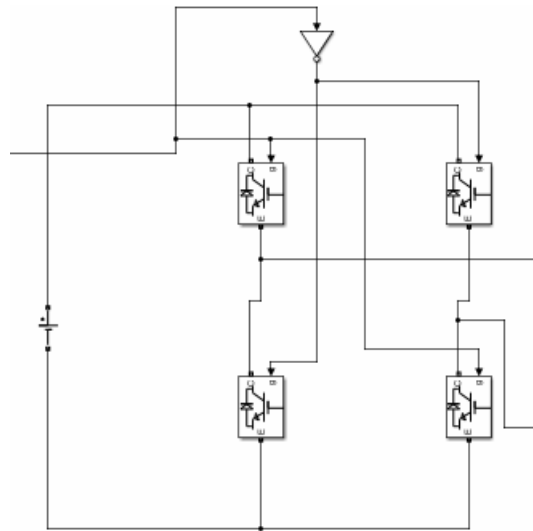

Figure 5.7: H-Bridge

The H-bridge in a four-switch buck-boost converter allows for bidirectional power flow: it selects the path of current and switches between buck and boost mode. It controls voltage and current with high efficiency to ensure seamless transitions in charging and discharging for smooth battery health. This is very important for modern electric vehicles, satisfying their various power demands efficiently. The rated current for the system is 60 A, and the rated voltage is 600 V. To calculate the power, we can use the formula:

$$P=V \times I$$

$$P=600 \text{ V} \times 60 \text{ A} = 36000 \text{ W}$$

Therefore, the total power of the system is 36000 watts.

This setup will be used for constructing the H-bridge circuit in our project:

- 4 IGBTs (60N60)
- 4 TLP250 (Gate Driver)
- 4 Capacitors (10 microfarad)
- 4 Capacitors (104)
- 4 Resistors (220 ohm)
- 4 Resistors (22 ohm)
- Arduino Uno
- Wires
- Breadboard

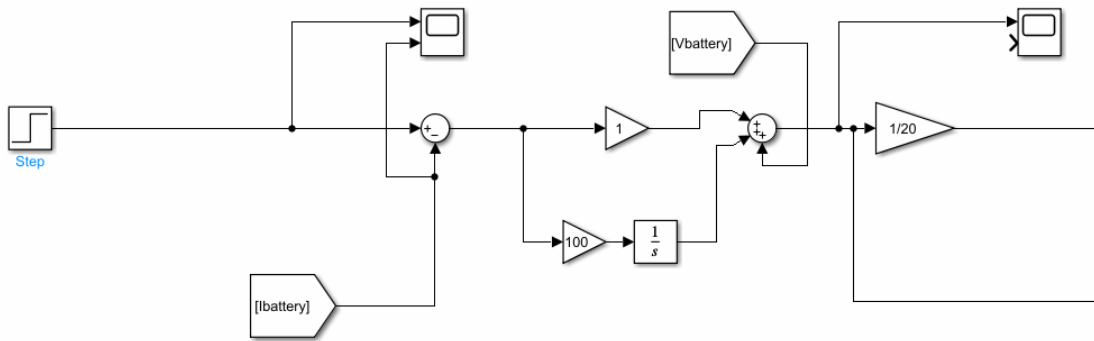

Figure 5.8: voltage controllers

The function of the voltage controllers consists of keeping the output voltage constant, regardless of any kind of load or input variations, by a continuous process of feedback: sensing the output voltage, comparing with a reference, generating an error signal, and applying a control algorithm (PI controller).

The controller therefore adjusts the PWM duty cycle of the converter to maintain consistent voltage delivery to the load at runtime.

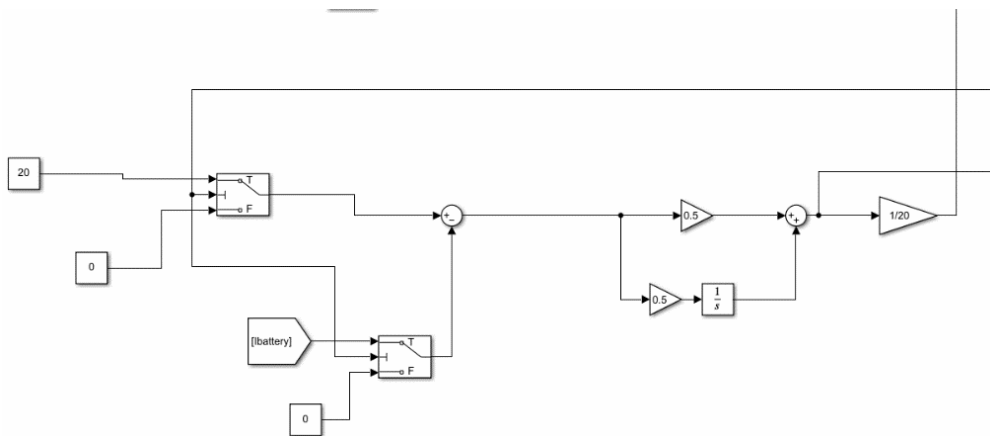

Figure 5.9: Current controllers

The current controllers regulate converter current to protect components and batteries from overcurrent damage. These controllers measure the current via sensors, compare it against a set limit, and generate an error signal when deviations occur. An error processed through a control algorithm (PI controller) makes changes to the PWM signals, hence dynamically modulating the switches to maintain the current within safety limits.

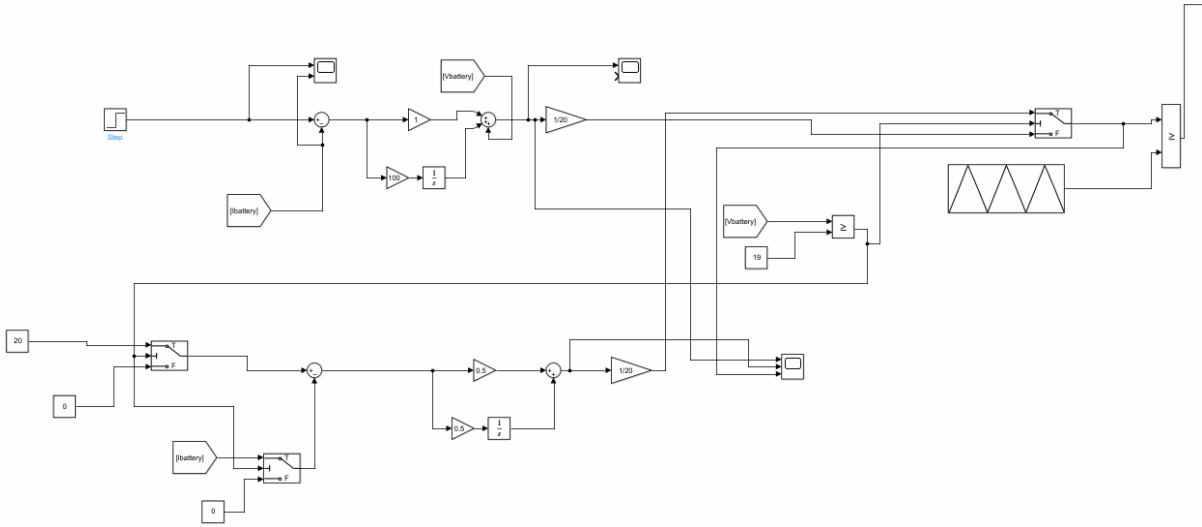

Figure 5.10: PWM and Current and Voltage controllers

PWM in buck-boost converters for EV batteries allows for better efficiency, lower EMI, and flexibility over a wide voltage range. Thus, PWM can be considered a very important component of the design in developing efficient and flexible EV charging systems that can deliver superior performance and reliability.

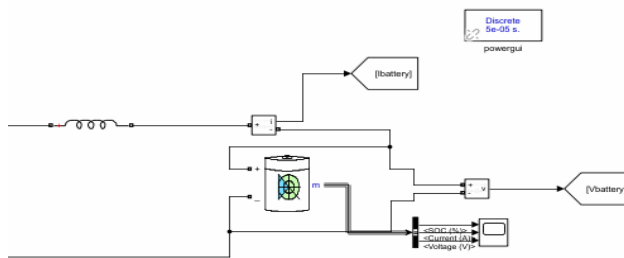

Figure 5.11: DC power source

It is considered to be a stable DC power source and an energy storage device for the system; therefore, it feeds the circuit with constant voltage. Power feeding is provided to various connected loads according to the needs of the system; in turn, charging and discharging of the battery are done correspondingly. In parallel with the battery, an inductor serves the function of regulating the flow of current and ripple reduction to reduce switching noise. It prevents abrupt changes in current and allows for smoother delivery of energy. The battery and the inductor

together contribute to the stability and efficiency of the system. They save the battery from operational fluctuations and ensure its longevity and reliability. The combination thus enables consistent power delivery and an overall better performance of the system.

5.8 Simulation Results:

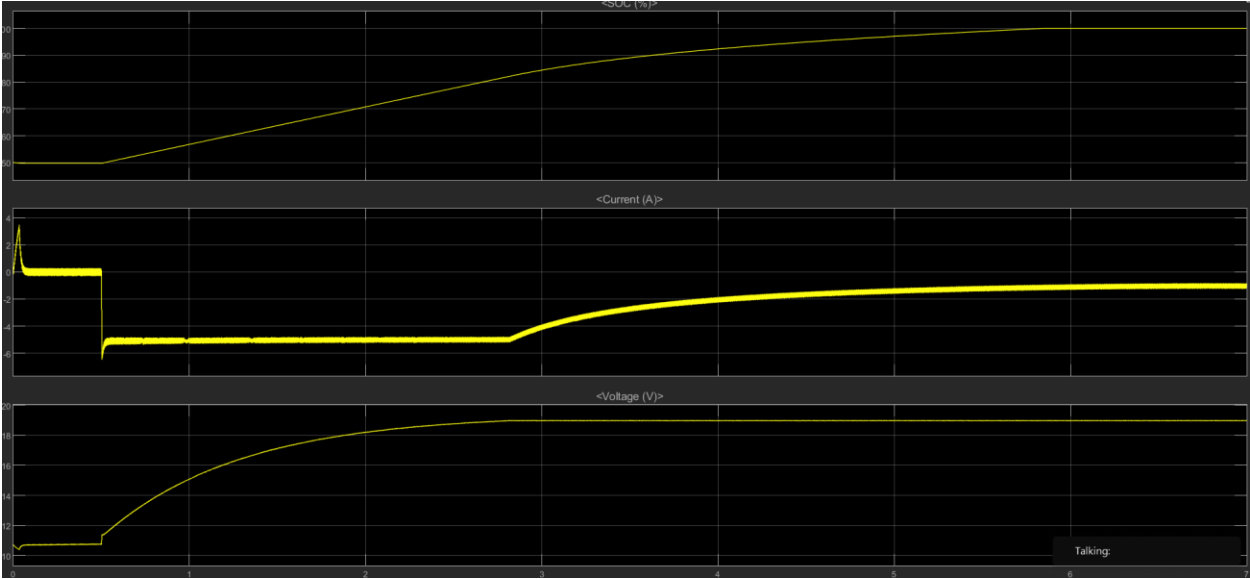

Figure 5.12: Output result

1. SOC:

- The curve shows a steady increase in the battery's charge percentage over time.
- The battery started with a charge state around 50% and gradually rose to nearly 100% as the charging progressed.
- This reflects the system's efficiency in delivering power to the battery continuously and stably.

2. Current:

- A short pulse is observed at the beginning of the operation, representing the inrush current during the initial charging phase.
- After this pulse, the current stabilizes at a negative value, indicating the battery charging process.
- There is a noticeable stability in the current throughout the charging phase, which reflects the steady performance of the DC/DC converter in regulating the current flowing to the battery.

3. Voltage:

- The voltage started at approximately 12V, which is the default initial voltage for the battery.
- The voltage gradually increased until it stabilized at around 20V.
- This indicates the success of the system in providing a higher voltage for charging when necessary, showcasing the effectiveness of the buck-boost technology in voltage regulation.

System Efficiency: The stable performance of both current and voltage indicates the efficiency of the 4-switch buck-boost converter in managing the charging process.

Charging Stability: The absence of significant fluctuations in voltage or current reflects the successful design of the system.

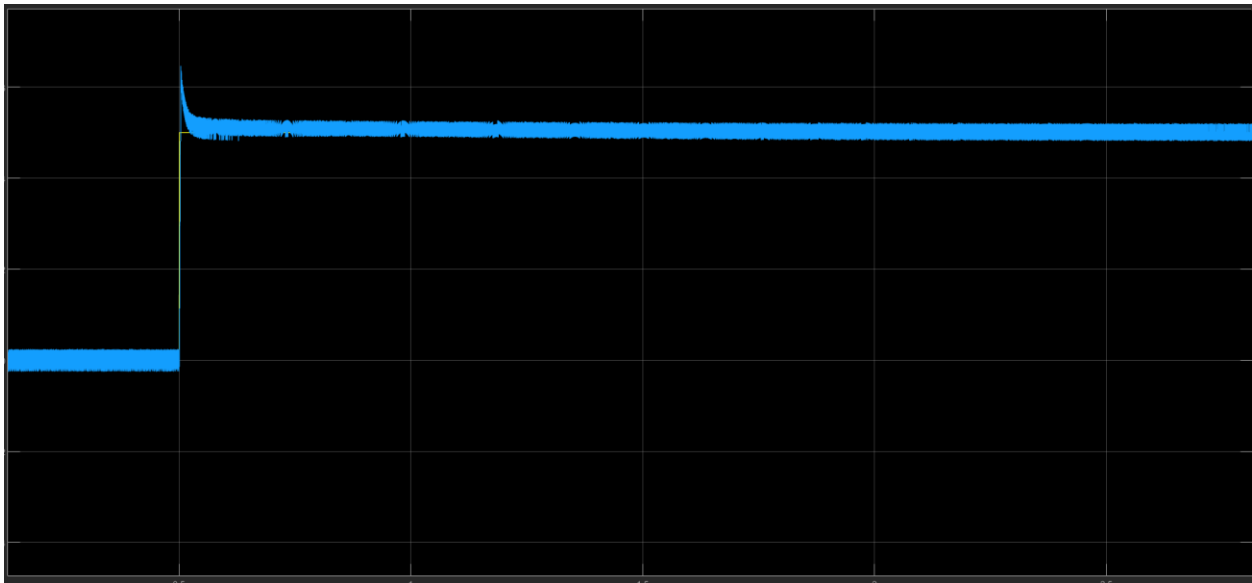

Figure 5.13: Reference voltage with battery voltage

The voltage reaches a steady state at a certain value, which is the goal of the process (matching the battery voltage with the reference voltage).

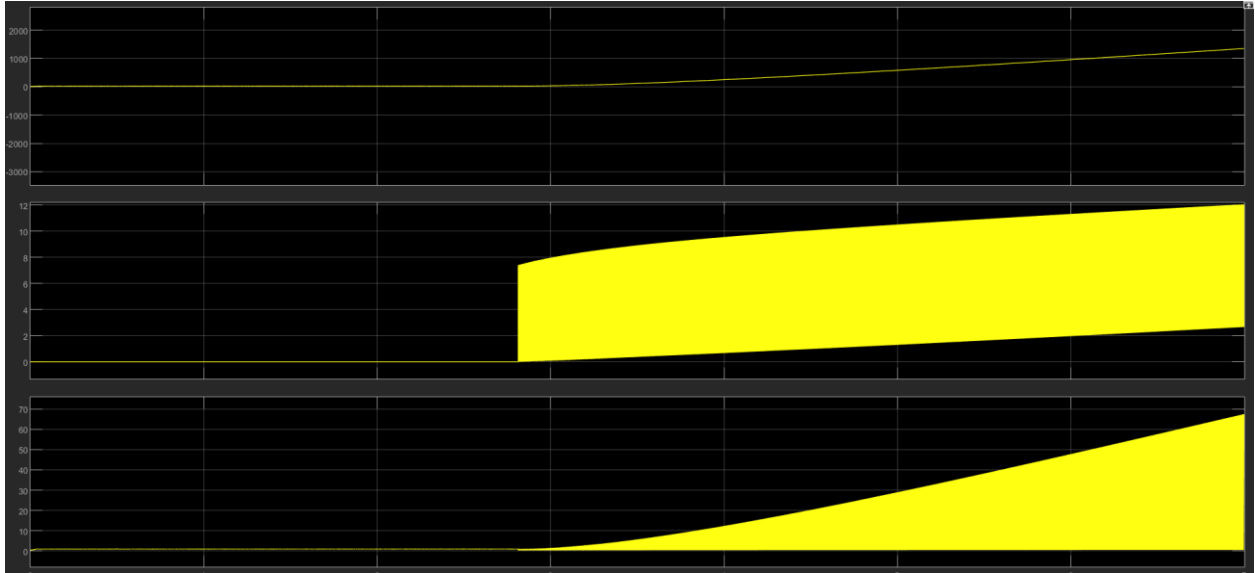

Figure 5.14: After adding current controller

The results show that the current is much more stable. The controller continuously monitors the current and compares it to a predefined reference value. If any deviation is detected, the controller adjusts the switching operation to ensure the current stays within safe limits. This protects the electronic components and the battery from excessive currents, which could otherwise lead to overheating or damage.



Figure 5.15: After adding voltage controller

The voltage is now more stable and closely aligned with the desired reference value. This is achieved using a feedback loop that constantly measures the system's output voltage and compares it to the required reference. Any error is processed by the controller, which adjusts the

duty cycle of the switches to ensure the voltage matches the target.

CH 6: Hardware

6.1 Hardware components

6.1.1 Li-ion Battery

Battery is an electric device which store the electric charges inside, and use these charges as electric energy when wanted. It has two terminals the cathode (indicates as positive terminal) and anode (the negative terminal).

There are two types of battery, the disposable and the rechargeable. Disposable are only used when they have enough charges stored inside, and then can't use them again when they fully discharged like alkaline battery. The rechargeable ones can discharge and charged multiple times using suitable dc source, example of them are Li-ion batteries which used in cars, phones, laptops and many other applications. They come in many shapes and sizes to be proper for their device.

In this project Li-ion batteries will be used which are rechargeable and have high energy density, lightweight and long cycle life.

How good a battery can be told according to many characteristics, and the most important ones are:

Energy density is the amount of energy a battery contains compared to its weight and size, and for li-ion batteries they have high energy density.

Life cycle is the number of charge and discharge cycles that a battery can complete before losing performance, and li-ion batteries have long life cycle compared to other traditional ones.

Self-discharge is a phenomenon in batteries in which internal chemical reactions reduce the stored charge of the battery without any connection between the electrodes or any external circuit, and also li-ion batteries have very low self-discharge.

During the discharge process, lithium ions move from the anode to the cathode through the electrolyte, generating electrical current. In the charging phase, this process is reversed. The choice of cathode materials impacts the battery's performance characteristics.

6.1.2 3.6V Lithium Battery

This battery was used as the secondary (receiving) battery during the charging operation. It served to simulate the energy storage device being charged by the main 12V source battery. During reverse operation, it acted as the power source in the discharge phase, demonstrating the bidirectional capability of the buck-boost converter. Its voltage and current were continuously monitored by the sensors and controlled via Arduino using PID feedback.



Figure6.1: Lithium Battery

6.1.3 Arduino Uno

Arduino is an open-source prototyping platform that combines both hardware and software in an easy-to-use environment. It consists of a programmable circuit board (microcontroller) and an Integrated Development Environment (IDE) used to write and upload code to the board.

The Arduino Uno board includes several essential components. Among them are the GPIO (General Purpose Input/Output) ports, which are used to interface with digital and analog inputs/outputs. At the core of the board is the ATmega328P microcontroller, which handles all processing tasks and controls the GPIOs according to the uploaded program.

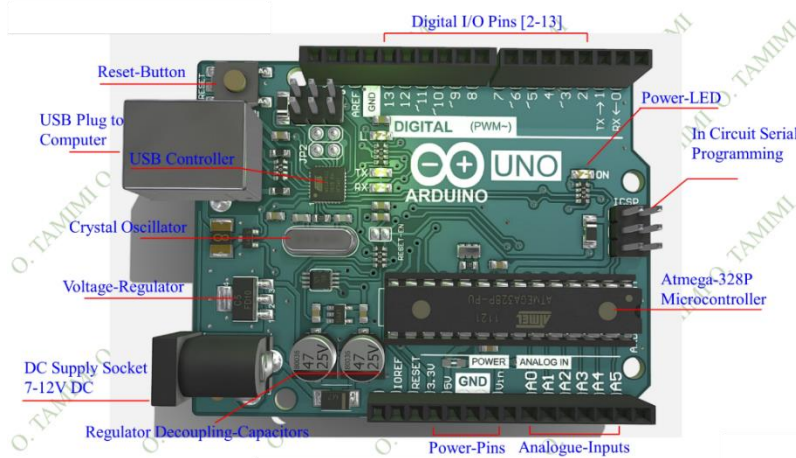

Figure 6.2: Arduino Uno

The board can be connected to a computer via a USB port, which is used both for programming and for supplying power. Additionally, the board can be powered through a DC input (7–12V) or via the power pins located near the analog I/O ports, with onboard regulation to 5V.

The Arduino Uno was the brain of the hardware system. It read voltage and current data from sensors, processed the PID control algorithm, and generated the PWM signals needed to drive the gate drivers of the H-Bridge. Additionally, it provided serial communication to input setpoints and plot data during closed-loop testing. Its Timer1 library was used to create high-frequency PWM signals, and another inverted signal was output for complementary switching.

6.1.4 H-Bridge

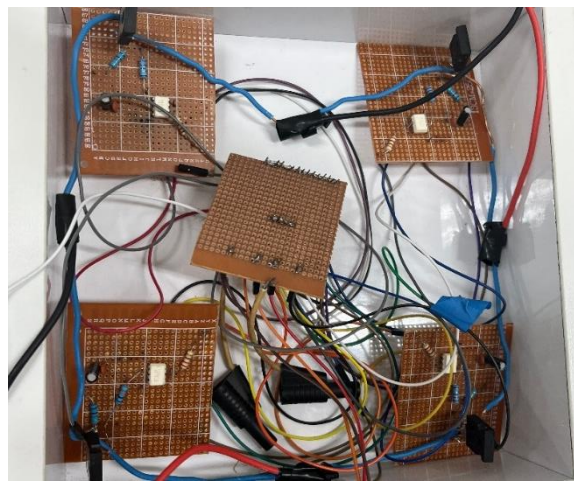

Figure 6.3: H-Bridge

The image above illustrates the practical implementation of the H-Bridge circuit used in the hardware phase of our four-switch Buck-Boost converter project. The design consists of four separate boards, each containing gate-driving components including a TLP250 optocoupler, resistors, capacitors, and a 60N60 IGBT. These boards are arranged in an H-shape to form the H-Bridge configuration.

This H-Bridge allows for bidirectional current flow, enabling the converter to operate in either Buck mode (voltage step-down) or Boost mode (voltage step-up), depending on the switching configuration. It plays a key role in managing both charging and discharging processes of the EV battery. The circuit's output signals were verified using an oscilloscope, which confirmed the correct switching behavior of each IGBT in response to the PWM signals.

The setup was connected to a stable DC voltage source, with an inductor used in parallel to filter the current and improve system stability. This implementation forms a core part of the complete converter system, offering dynamic control over both the input and output voltage and current levels.

6.1.5 Current Sensor

In this system, the current sensor plays a critical role in monitoring the flow of current between

the batteries during both charging and discharging phases. It converts the measured current into a proportional analog voltage signal, which is read by the Arduino's analog input pins. This signal serves as the real-time feedback input to the PID control algorithm implemented in the Arduino.

The controller continuously adjusts the PWM duty cycle of the H-Bridge switches to ensure the actual current closely matches the user-defined setpoint. Beyond regulation, the current sensor enhances system stability and accuracy, and acts as a protection element. The system can be configured to halt operation automatically if the sensed current exceeds a predefined threshold, thereby safeguarding both the batteries and electronic components from potential damage.



Figure 6.4: current sensor

6.1.6 Voltage Sensor

The voltage sensor provided real-time voltage feedback from the battery to the Arduino. This allowed dynamic adjustment of the PWM duty cycle to maintain the desired charging or discharging voltage. It contributed to overall voltage regulation during the operation of the converter.

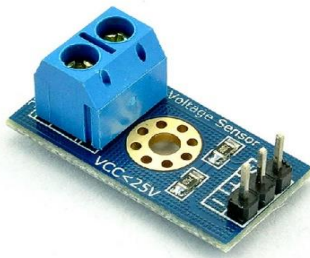

Figure 6.5 voltage sensor

6.1.7 MG 6-MG-9 Sealed Battery

A battery of type **MG 6-MG-9** with a nominal voltage of 12V and high discharge capability was used in the project. This battery is suitable for high-rate discharge applications and supports a charging voltage range between 13.5V and 14.7V, with a maximum initial charging current of less than 2.7A. It was selected to serve as the primary power source in the buck-boost charging and discharging system. Its voltage and current are continuously monitored using appropriate

sensors and controlled via an Arduino board to ensure safe and stable operation. The battery's placement in the circuit allows for accurate voltage and current feedback, which is essential for implementing real-time PID-based control



Figure 6.6: MG 6-MG-9 Sealed Battery

6.1.8 Oscilloscope

An oscilloscope was used to monitor and analyze the behavior of voltage and current waveforms in real-time throughout the circuit. It allowed us to verify the switching operation of the H-Bridge, observe PWM signals generated by the Arduino, and ensure the overall stability and performance of the buck-boost converter during both charging and discharging phases.

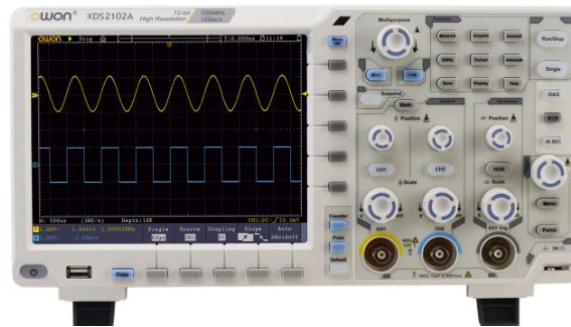

Figure 6.61: Oscilloscope

6.2 Hardware Design

6.2.1 Hardware Implementation

In the practical implementation of the system, a complete hardware setup was built to control the charging of a lithium battery using a four-switch buck-boost DC-DC converter. The circuit was designed around the Arduino Uno, which serves as the core controller. The charging current is regulated using PWM signals generated by the Arduino, with feedback taken from current and voltage sensors.

A 13V battery was used as the primary power source, supplying energy to charge the lithium battery. An H-Bridge module (L298N) was used to switch and control the current flow between the two batteries. A large inductor was placed between the H-Bridge and the lithium battery to stabilize current and simulate buck-boost converter behavior.

The current flowing into the lithium battery was measured using a current sensor connected to analog pin A0 on the Arduino, while two voltage sensors were used to monitor the voltages of both the source battery and the lithium battery. The system was tested using both a physical oscilloscope to view the PWM waveform, and computer-based tools to visualize the current, voltage, and controller response.

6.2.2 Operating Principle

The charging process is controlled through a PID (Proportional–Integral–Derivative) control algorithm implemented on the Arduino Uno. The user inputs a setpoint (target current value) via the serial monitor on a connected computer. The Arduino continuously reads the actual current from the current sensor and compares it to the setpoint. The difference (error) is processed using the PID control formula to calculate a new PWM duty cycle.

The PWM signal is sent from the Arduino to the L298N H-Bridge, which switches power from the 13V source battery to the lithium battery. A higher duty cycle results in more ON-time in the switching cycle, allowing more current to flow and charge the battery. When the error between the setpoint and the actual current decreases, the PWM is adjusted to maintain steady-state charging.

Throughout this process, the voltage sensors monitor the voltages of both batteries to ensure safe operation. The system allows both open-loop and closed-loop testing to compare controlled versus uncontrolled charging behavior.

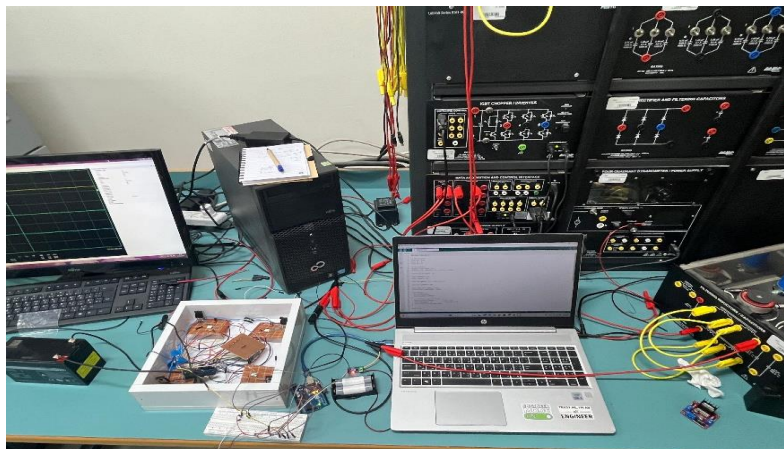

Figure 6.62: Hardware Design

6.2.3 Power Stage: H-Bridge Configuration

At the heart of the system lies the H-Bridge circuit, which consists of four IGBTs (type 60N60) configured in an "H" topology. Each IGBT is driven by a TLP250 opto-isolated gate driver, which receives PWM signals from the Arduino. The IGBTs are responsible for switching the current paths through the load, allowing the converter to operate in both **Buck** (step-down) and **Boost** (step-up) modes depending on the direction of power flow and the duty cycle of the switching signals.

The H-Bridge allows **bidirectional power flow**, which means the system can:

Charge the 3.6V lithium battery from the 12V battery (Buck mode).

Discharge the 3.6V battery to charge the 12V battery (Boost mode).

The inductor connected in series with the battery path smooths out the current flow and stores energy during switching, a fundamental part of any DC-DC converter.

6.2.4 Control and Sensing Stage (Arduino + Sensors)

An **Arduino Uno** is used as the main controller in the system. It performs the following tasks:

Reads **current and voltage** values using:

A **current sensor**, which measures the charging/discharging current and sends an analog signal.

A **voltage sensor**, which monitors the battery voltage.

Applies a **PID control algorithm** to compare the measured current (or voltage) to a user-defined **setpoint** and adjusts the PWM duty cycle accordingly.

Generates PWM signals using **TimerOne library** to control the H-Bridge switches. Additionally, a complementary inverted PWM signal is generated for the second leg of the H-Bridge using a separate Arduino output pin.

Accepts setpoint input from the user via the **Serial Monitor**, and optionally plots live current/voltage data using the **Arduino Serial Plotter** for real-time observation.

6.2.5 Energy Sources” Batteries”

Two types of batteries were used:

3.6V Lithium-ion Battery: Served as the low-voltage battery to be charged/discharged.

12V MG 6-MG-9 Battery: Functioned as the high-voltage source/sink.

The batteries were connected in such a way that the H-Bridge could control energy transfer in either direction, simulating real-world battery charging and energy recovery scenarios.

6.2.6 Real-Time Monitoring: Oscilloscope

An **oscilloscope** was connected across the gate terminals of the IGBTs and at various points in the circuit to:

Observe the PWM switching behavior.

Measure voltage and current waveforms.

Validate the system operation in both **open-loop** and **closed-loop** modes.

This helped in tuning the PID parameters and verifying the correct functioning of the converter during experimental runs

6.3 Hardware Results

H-bridge: Output result for H-Bridge



Fig. 6.3.1 PWM Output Signal from Arduino to L298N H-Bridge

This figure shows the PWM signal output from the control unit (Arduino Uno) to the H-Bridge circuit (L298N module) during system testing. The PWM signal, modulated by the PID algorithm in the Arduino, controls the current flow between batteries during charging and discharging through the four-switch Buck-Boost converter.

- **Signal Type:** PWM, adjusted for precise current control.
- **Frequency:** Approximately 1 kHz using the TimerOne library.

- **RMS Voltage:** 13.89
- **Average Voltage (AVG):** 4.29 V

These values demonstrate the system’s effectiveness in regulating current by adjusting the PWM duty cycle, maintaining stable current during charging. The figure shows stable and consistent control output, indicating successful operation in keeping a steady and safe current.

The H-Bridge plays a key role in directing current bidirectionally depending on the mode (Buck or Boost), enabling two-way energy transfer between batteries.

Based on these results, the system achieves high efficiency in power management and successfully regulates current and voltage, ensuring safe operation and prolonging battery life

6.3.2 Current sensor calibration code

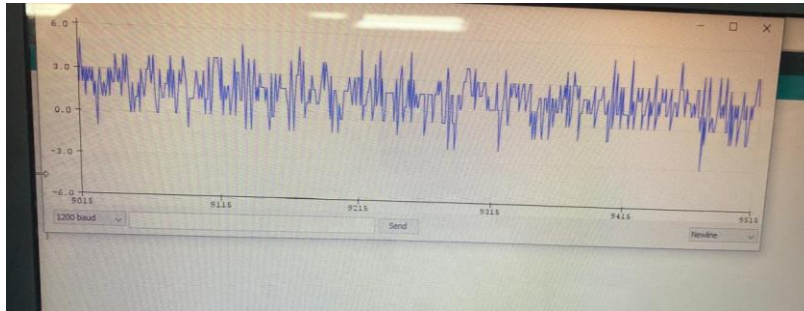
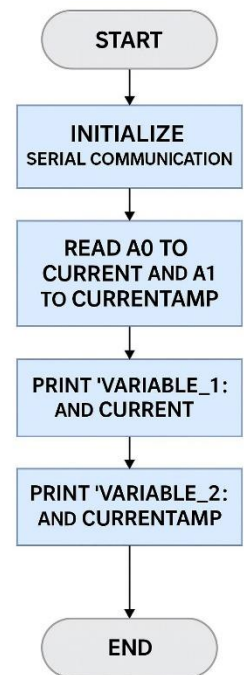

Fig 6.3.2 Current sensor calibration

This test was performed to calibrate the current sensor and identify the zero-current reference value. It was observed that `analogRead(A0)` gives approximately 508 when no current flows. Based on this, the code subtracts 508 from the sensor reading to convert it into a valid positive or negative current. This calibration is essential to ensure accurate current control in the system.



6.3.3 Code PID controller:

In this project, a PID (Proportional–Integral–Derivative) control algorithm was implemented using Arduino C to regulate the charging current of a lithium battery through a four-switch buck-boost converter. The Arduino Uno serves as the main controller, running the PID loop to ensure stable and accurate current regulation.

The system operates by comparing a user-defined setpoint, entered via the Serial Monitor, with the actual current measured from a sensor on analog pin A0. The error is processed using PID control with parameters: $K_p = 2.0$, $K_i = 5.0$, and $K_d = 0.0$ (to reduce overshoot). Based on the output, a PWM signal is generated at 1 kHz using the TimerOne library and sent to pin 9 to drive one leg of the L298N H-Bridge.

A second, inverted PWM signal is sent to pin 5 using `analogWrite()`, allowing complementary switching. This dual PWM configuration controls the direction of current flow, enabling the converter to operate in both Buck (charging) and Boost (discharging) modes. Positive setpoints drive current from the 12V source to the lithium battery, while negative setpoints reverse the flow.

Real-time current and setpoint values are visualized through the Serial Plotter, helping evaluate system behavior and adjust PID tuning. Overall, the code provides a closed-loop control system for safe, bidirectional charging and discharging of the battery.

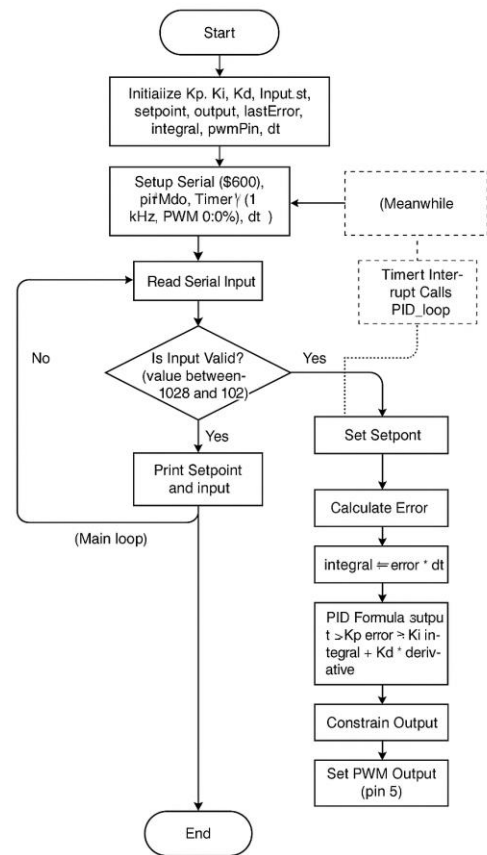

6.3.4 Open loop status

□ **Open Loop:** The system sends a fixed PWM signal to the H-Bridge without measuring the actual current. The duty cycle is manually adjusted, and the system does not react to changes in load or battery state. This can lead to unstable or inefficient charging

6.3.5 Drawing and values of current and voltage

1-VALUE 670

PWM:

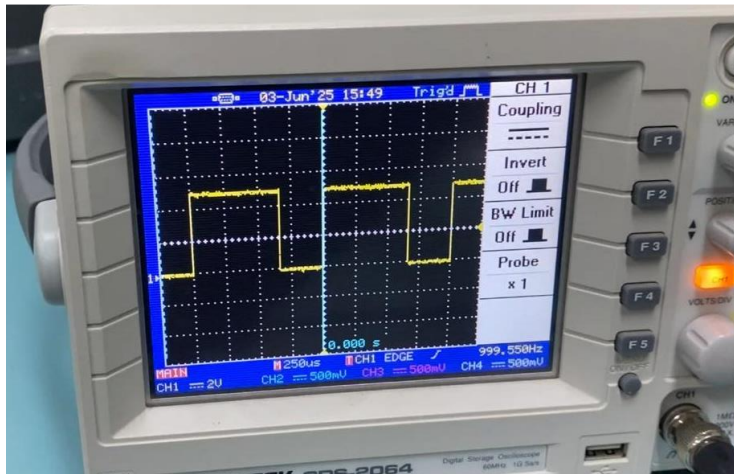

When a value of 670 is entered in open-loop mode, a PWM signal with approximately 65.5% duty cycle is generated. Due to the H-Bridge configuration and the use of an inverted PWM signal on the opposite leg, this value creates a balanced state with nearly zero net current. It acts as a neutral baseline for system calibration



CURRENT AND VOLTAGE VALUE:

Measurements show that no actual current flows through the circuit, as the system maintains balance. Voltage remains stable with no significant fluctuation. This condition represents a "neutral" state used for calibrating the system's zero-current point.

2-VALUE 750

PWM:

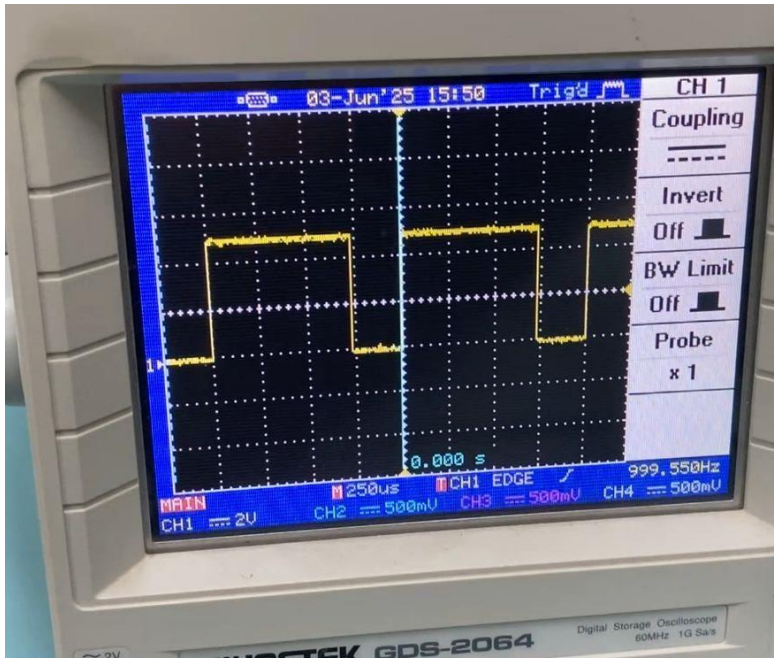

Increasing the value to 750 increases the PWM duty cycle to about 73%, allowing more power transfer from the 12V battery to the lithium battery. This puts the system in Buck mode (voltage step-down).

CURRENT AND VOLTAGE VALUE:



The increase in current and voltage indicates active power transfer from the source to the load. Without closed-loop control, fluctuations and instability may occur, emphasizing the importance of using PID.

3-VALUE 550

PWM:

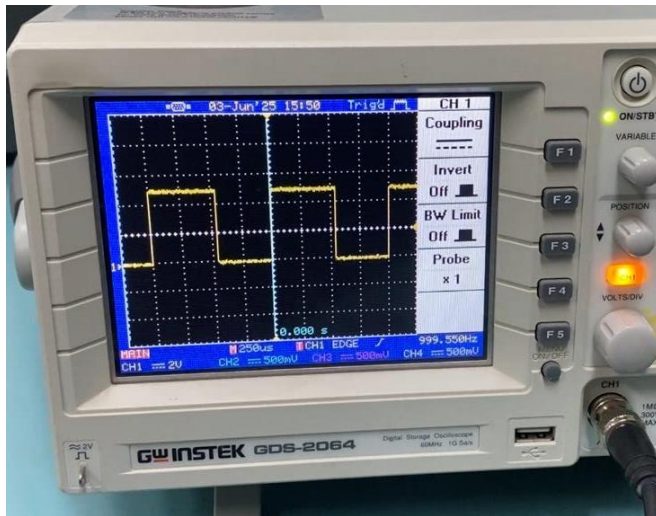

Lowering the PWM value to 550 decreases the energy sent to the battery, resulting in a slower charging current. This test helps evaluate the impact of manual PWM adjustment on performance.

CURRENT AND VOLTAGE VALUE:



The lower current and voltage indicate reduced power delivery, but the lack of stability suggests the need for a control loop to maintain consistent values.

6.3.6 Closed loop condition

Closed Loop: The system uses a current sensor to measure real-time current, compares it to the user-defined setpoint, and adjusts the PWM using a PID controller. This provides dynamic, stable, and accurate current control.

Setpoint = -5 (Closed Loop)

plotter

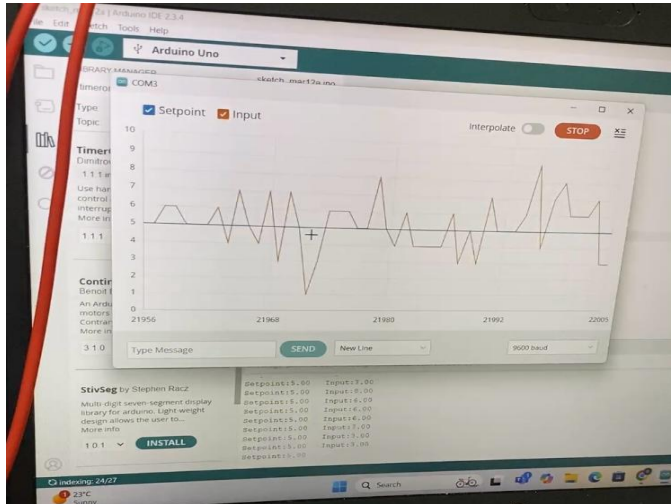

PWM

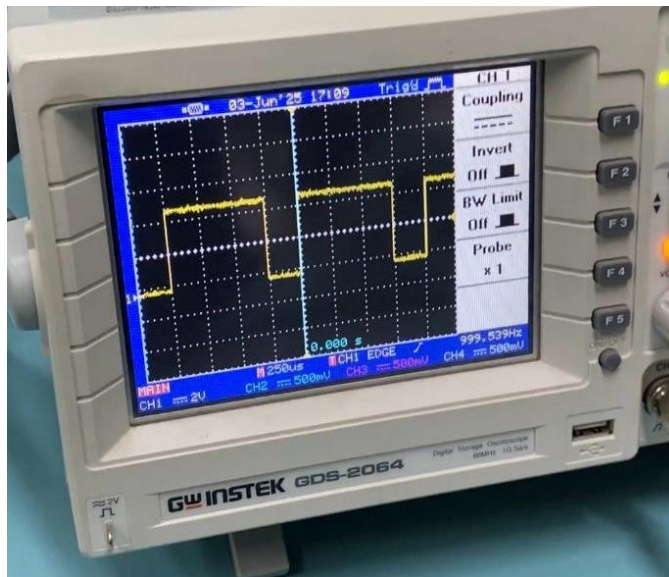

6.3.7 Drawing and values of current and voltage:



Setpoint = 5

In this test, a setpoint value of 5 was entered, indicating a low charging current target. The Arduino PID controller compared this target with the actual current measured by the current sensor and adjusted the PWM signal accordingly.

The PWM waveform showed a moderate duty cycle. The Serial Plotter showed the input line gradually approaching and matching the setpoint.

The current was positive and stable, indicating a smooth charging process. The system operated in buck mode since the 13V source was supplying current to a lower voltage lithium battery.

Setpoint = 10 (Closed Loop)

PLOTTER

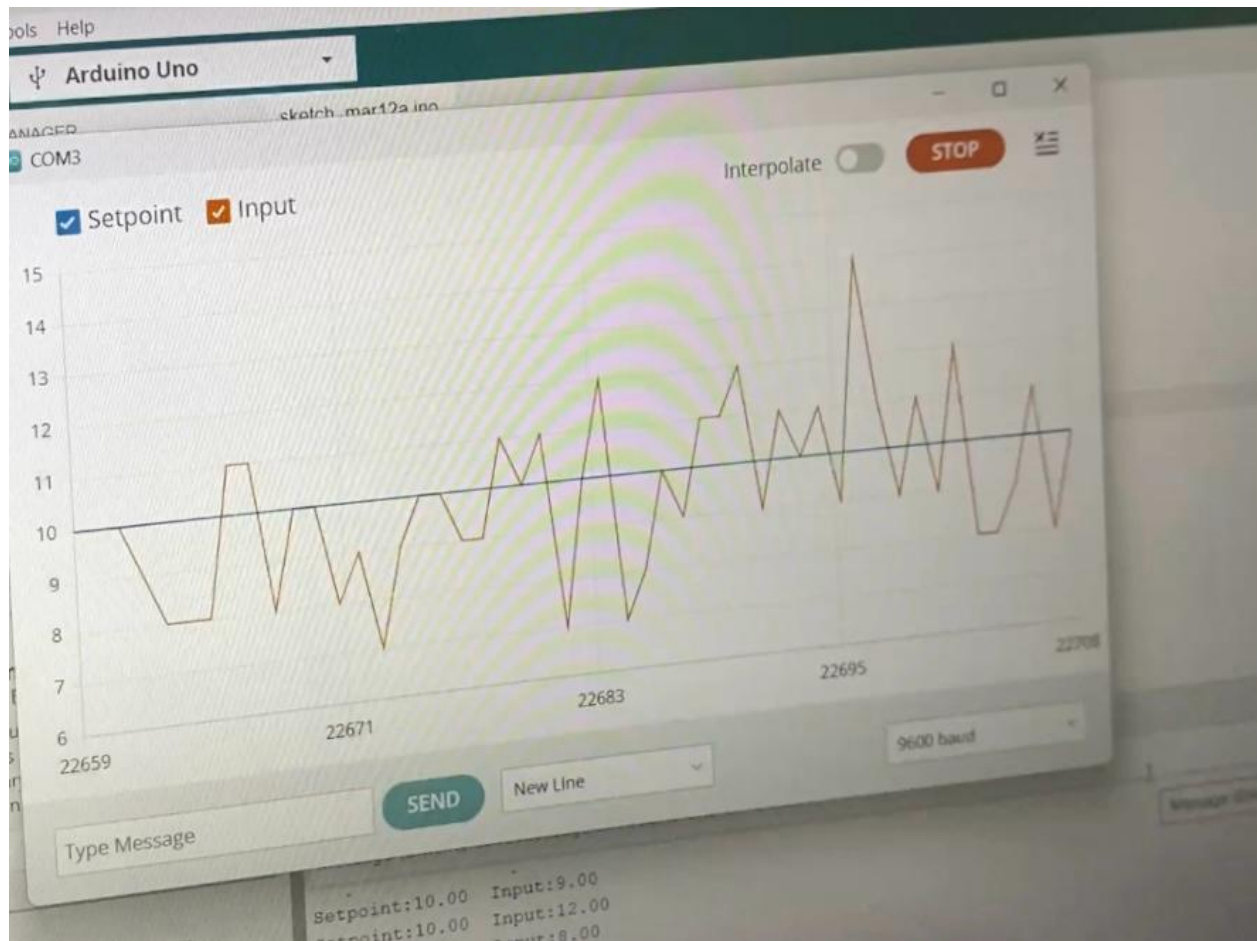

PWM

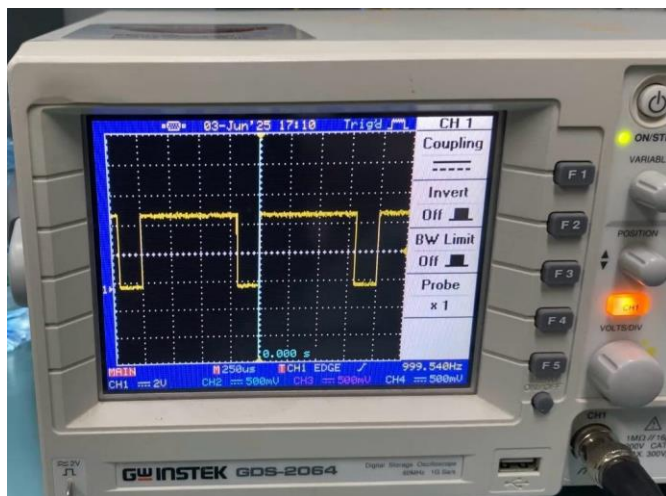

Drawing and values of current and voltage:

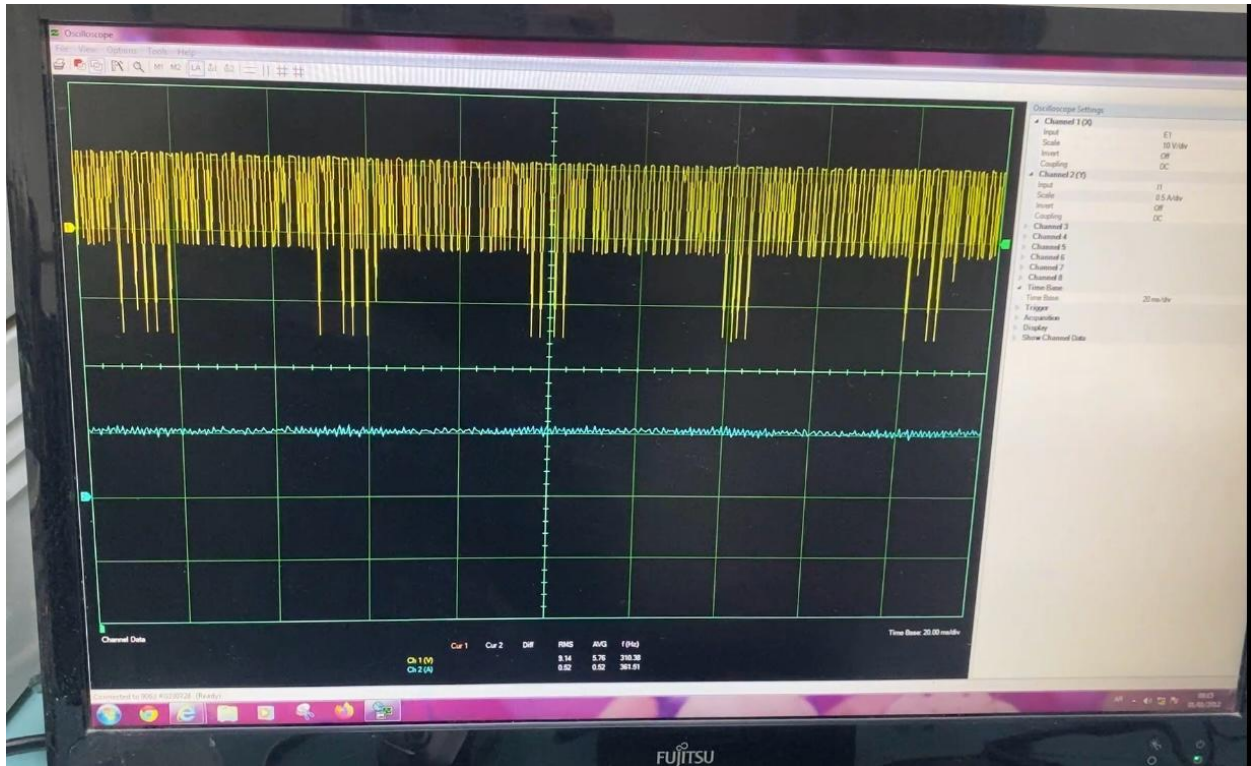

setpoint = 10

A higher setpoint of 10 was used to increase the charging current. The PID controller responded by increasing the PWM duty cycle, resulting in more ON-time and higher power delivery. The oscilloscope showed a nearly flat-top PWM waveform. The Serial Plotter confirmed that the measured input current increased and matched the setpoint. The battery was charged more quickly, and the system continued to operate in buck mode.

Setpoint = -5 (Closed Loop)

PLOTTER

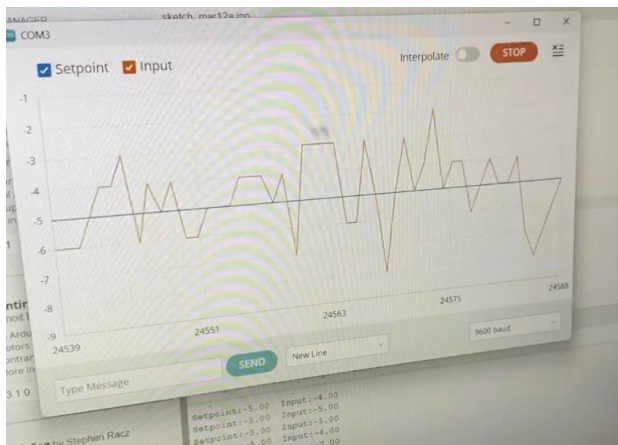

PWM

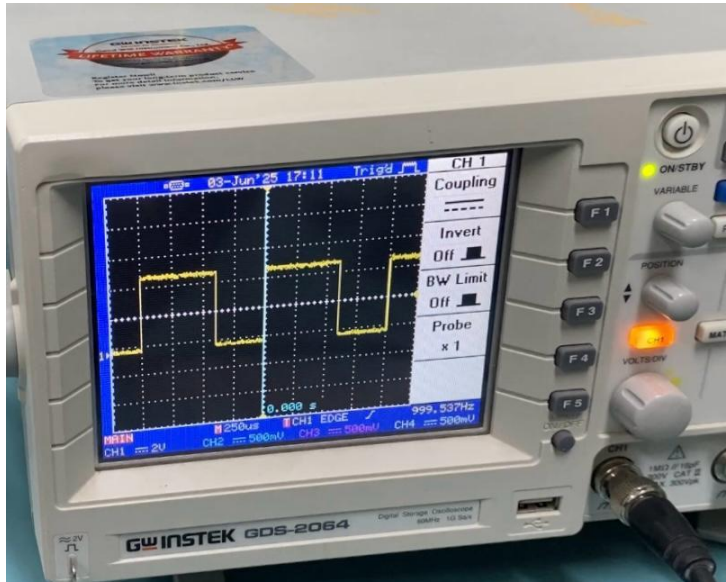

Drawing and values of current and voltage:

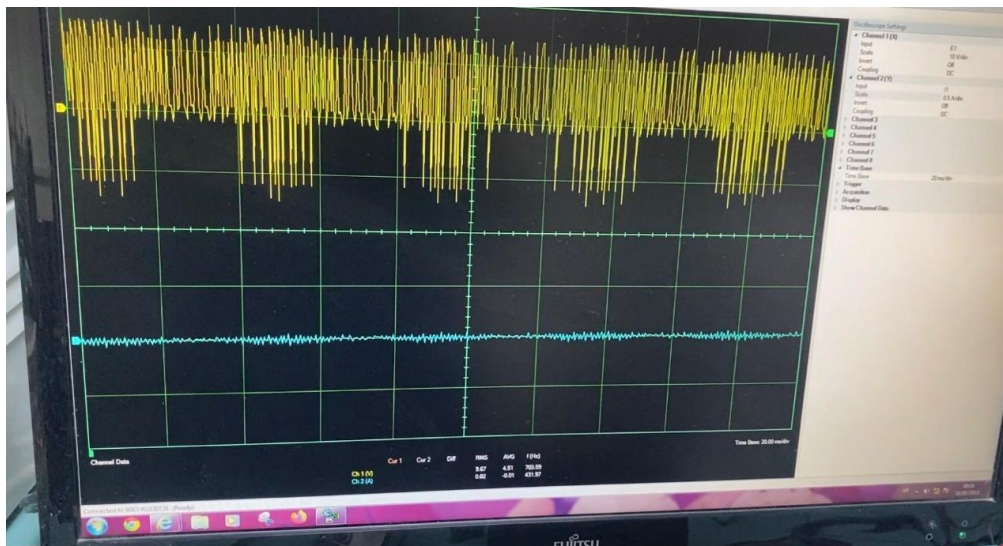

Setpoint = -5

A negative setpoint of -5 was entered, instructing the system to reverse the current flow—effectively discharging the lithium battery.

The Arduino adjusted the PWM signals and reversed the output polarity using the H-Bridge. The Serial Plotter showed a negative current, and the system operated in boost mode, sending energy back from the lower voltage battery to the higher voltage source.

Setpoint = -10 (Closed Loop)

PLOTTER

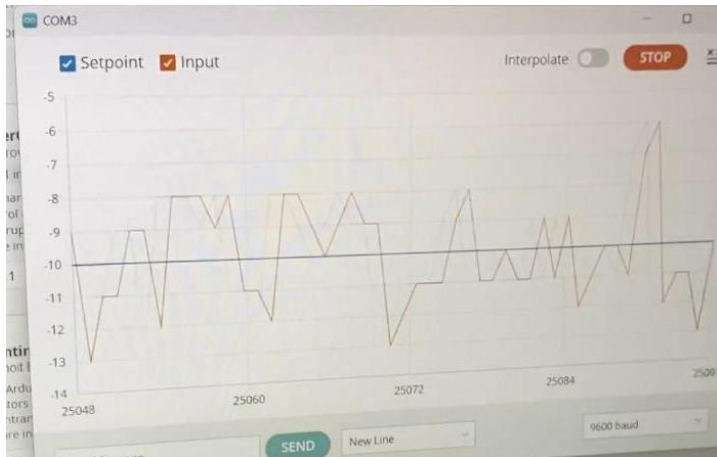

PWM

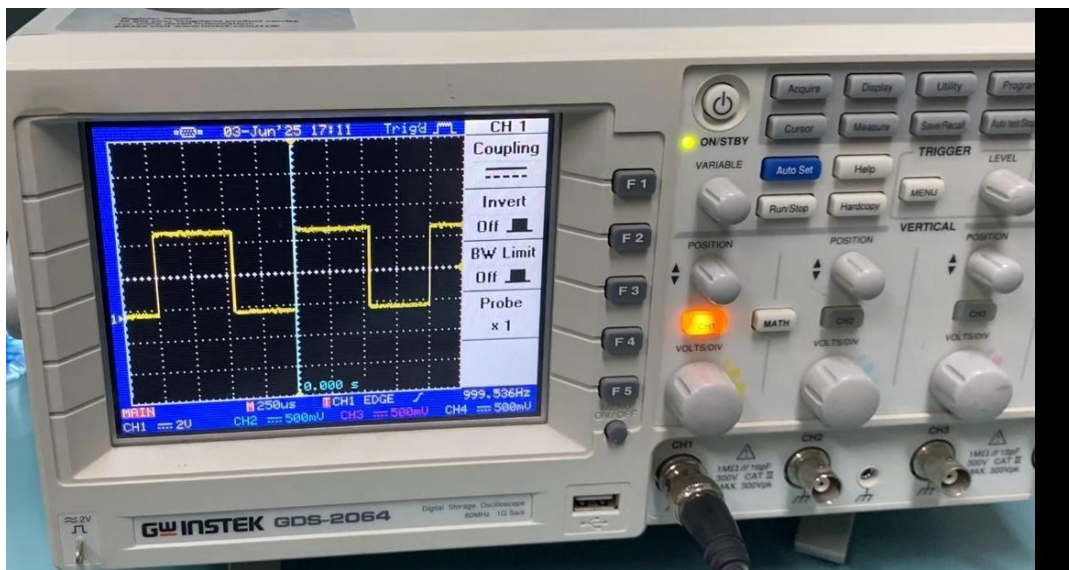

Drawing and values of current and voltage:

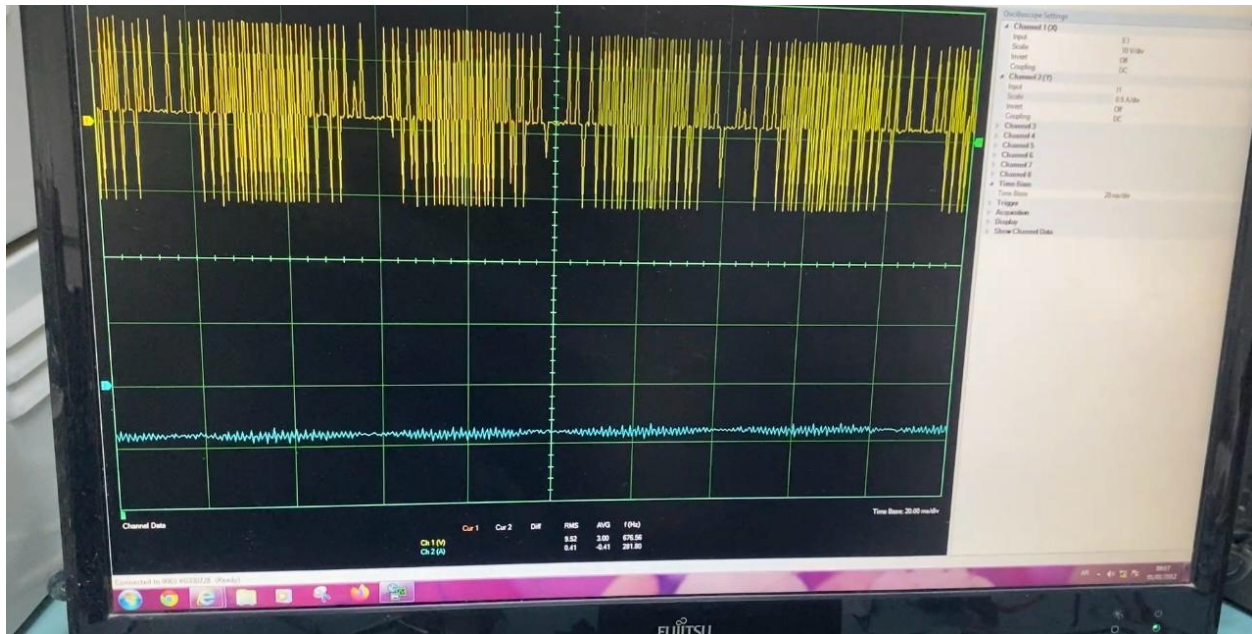

Setpoint = -10

A more aggressive discharge was tested with a setpoint of -10. The system increased the reversed PWM duty cycle to allow higher current flow from the lithium battery.

The current measured was negative and stable.

The plotter confirmed this by showing the input line matching the setpoint. The system-maintained boost mode operation

Project Development Videos

https://drive.google.com/drive/folders/1RDoc_jTMOe7TSepaNN87HkkChNwLLeiS?usp=sharing

Chapter 7: Conclusion and Future Work

7.1. Conclusion

vehicles using a **Four-Switch Buck-Boost DC/DC Converter**. Through the combination of simulation and practical implementation, we demonstrated a robust system capable of regulating both current and voltage during charging and discharging phases.

In the **simulation phase**, a detailed Simulink model was developed to evaluate the converter's behavior under different load and input conditions. The results confirmed that the system effectively transitions between Buck and Boost modes, maintaining voltage and current stability. This highlights the converter's capability to handle real-world EV charging demands.

In the **hardware implementation**, an actual circuit was built using an Arduino Uno, current and voltage sensors, and an H-Bridge composed of IGBTs and gate drivers. A PID control algorithm was applied to dynamically adjust PWM signals based on sensor feedback. The experimental results showed **accurate control over charging current**, smooth switching behavior, and consistent voltage regulation — all of which validate the success of the proposed system.

In summary, **the proposed method improved the efficiency, reliability, and safety of battery charging**, making it a viable solution for real-world EV applications. Both theoretical and practical results proved the effectiveness of the Four-Switch Buck-Boost Converter in enhancing EV battery performance.

7 2.Future Work:

To further develop and refine this project, the following future enhancements are proposed:

- **System Scaling:**
Test the converter with higher power batteries and real EV-scale systems to evaluate industrial-level performance.
- **Component Upgrades:**
Replace IGBTs with advanced semiconductor materials such as SiC or GaN to reduce losses and improve switching speed.
- **Thermal Management:**
Integrate heat sinks and real-time thermal monitoring to ensure safe operation under high-power conditions.
- **User Interface:**
Develop a visual display (LCD or mobile app) to monitor battery state, voltage, current, and system status in real time.
- **Smart Control:**
Implement adaptive or AI-based control strategies to further optimize charging efficiency under varying battery conditions.
- **Renewable Energy Integration:**
Enable compatibility with solar panels or other renewable sources for off-grid or green energy applications.

References

- [1] Khan, M. I., Gilani, R., Hafeez, J., Ayoub, R., Zahoor, I., & Saira, G. (2025). Advantages and disadvantages of lithium-ion batteries. In *Nanostructured Lithium-ion Battery Materials* (pp. 47-64). Elsevier.
- [2] Lavanya, N., et al. "Introduction and history of lithium-ion batteries." *Nanostructured Lithium-ion Battery Materials*. Elsevier, 2025. 3-20.
- [3] Li, Xiao, Yushan Liu, and Yaosuo Xue. "Four-switch buck–boost converter based on model predictive control with smooth mode transition capability." *IEEE Transactions on Industrial Electronics* 68.10 (2020): 9058-9069.
- [4] Mollaei, Hasan, et al. "A novel adaptive cascade controller design on a buck–boost DC–DC converter with a fractional-order PID voltage controller and a self-tuning regulator adaptive current controller." *IET Power Electronics* 14.11 (2021): 1920-1935.
- [5] IEEE, I. "IEEE recommended practices and requirements for harmonic control in electrical power systems." New York, NY, USA (1993): 1-1.
- [6] Singh, G.K., 2009. Power system harmonics research: a survey. *European Transactions on Electrical Power*, 19(2), pp.151-172.
- [7] Hannan, M.A.; Lipu, M.H.; Hussain, A.; Mohamed, A. A review of lithium-ion battery state of charge estimation and management system in electric vehicle applications: Challenges and recommendations. *Renew. Sustain. Energy Rev.* 2017, 78, 834–854. [CrossRef]
- [8] Adaikkappan, M.; Sathiyamoorthy, N. Modeling, state of charge estimation, and charging of lithium-ion battery in electric vehicle: A review. *Int. J. Energy Res.* 2022, 46, 2141–2165.
- [9] Eddahech, Akram, Olivier Briat, and Jean-Michel Vinassa. "Real-time SOC and SOH estimation for EV Li-ion cell using online parameters identification." *2012 IEEE Energy Conversion Congress and Exposition (ECCE)*. IEEE, 2012.
- [10] Blanes, José M., et al. "Electric vehicle battery life extension using ultracapacitors and an FPGA controlled interleaved buck–boost converter." *IEEE Transactions on Power Electronics* 28.12 (2013): 5940-5948.
- [11] Nayak, P. Srinivasa Rao, et al. "Design and simulation of BUCK-BOOST type dual input DC-DC converter for battery charging application in electric vehicle." 2021

International Conference on Sustainable Energy and Future Electric Transportation (SEFET). IEEE, 2021.

- [12] Lipu, M.H.; Hannan, M.; Hussain, A.; Hoque, M.; Ker, P.J.; Saad, M.M.; Ayob, A. A review of state of health and remaining useful life estimation methods for lithium-ion battery in electric vehicles: Challenges and recommendations. *J. Clean. Prod.* 2018, 205, 115–133.
- [13] Mc Carthy, K.; Gullapalli, H.; Kennedy, T. Real-time internal temperature estimation of commercial Li-ion batteries using online impedance measurements. *J. Power Sources* 2022, 519, 230786.
- [14] Locorotondo, E.; Cultrera, V.; Pugi, L.; Berzi, L.; Pierini, M.; Lutzemberger, G. Development of a battery real-time state of health diagnosis based on fast impedance measurements. *J. Energy Storage* 2021, 38, 102566.
- [15] Uiterkamp, M.H.S.; Gerards, M.E.; Hurink, J.L. Online electric vehicle charging with discrete charging rates. *Sustain. Energy Grids Netw.* 2021, 25, 100423.
- [16] Zhou, W.; Zheng, Y.; Pan, Z.; Lu, Q. Review on the battery model and SOC estimation method. *Processes* 2021, 9, 1685.
- [17] Estaller, J.; Kersten, A.; Kuder, M.; Thiringer, T.; Eckerle, R.; Weyh, T. Overview of Battery Impedance Modeling Including Detailed State-of-the-Art Cylindrical 18650 Lithium-Ion Battery Cell Comparisons. *Energies* 2022, 15, 3822.
- [18] Aghajan-Eshkevari, S.; Azad, S.; Nazari-Heris, M.; Ameli, M.T.; Asadi, S. Charging and discharging of electric vehicles in power systems: An updated and detailed review of methods, control structures, objectives, and optimization methodologies. *Sustainability* 2022, 14, 2137.
- [19] Uzair, M.; Abbas, G.; Hosain, S. Characteristics of Battery Management Systems of Electric Vehicles with Consideration of the Active and Passive Cell Balancing Process. *World Electr. Veh. J.* 2021, 12, 120.
- [20] Habib, A.A.; Hasan, M.K.; Islam, S.; Ahmed, M.M.; Aman, A.H.M.; Bagwari, A.; Khan, S. Voltage equalization circuit for retired batteries for energy storage applications. *Energy Rep.* 2022, 8, 367–374 .
- [21] Barcellona, S.; Colnago, S.; Dotelli, G.; Latorrata, S.; Piegari, L. Aging effect on the variation of Li-ion battery resistance as function of temperature and state of charge. *J. Energy Storage* 2022, 50, 104658 .

- [22] Zhang, L.; Yang, Z.; Hu, F.; Feng, X.; Li, D.; Chen, Y. Reversible Al-Site Switching and Consequent Memory Effect of Al-Doped Li₄Ti₅O₁₂ in Li-Ion Batteries. ACS Appl. Mater. Interfaces 2020, 12, 17415–17423.
- [23] Robert W. Erickson and Dragomir Maksimović, *Fundamentals of Power Electronics*. SECOND EDITION, Springer International Edition.
- [24] R. Tymerski and V. Vorperian, *Generation, Classification and Analysis of Switched-mode DC to DC Converters by the use of Converter Cells*. Proc. INTELEC'86, pp. 181-195, Oct. 1986.
- [25] Lopa SA, Hossain S, Hasan MK, Chakraborty TK. Design and simulation of DC-DC converters. International Research Journal of Engineering and Technology (IRJET). 2016 Jan;3(01):63-70.
- [26] Electric Power Systems book by Ned Mohan and Electrical Drives book.
- [27] Pulse Width Modulated DC-to-DC Power Conversion: Circuits, Dynamics, Control, and DC Power Distribution Systems by Byung Cho Choi.
- [28] IEEE Xplore
- [29] https://en.wikipedia.org/wiki/History_of_the_battery
- [30] Proteus 8 Professional application
- [31] Split Converter-Fed SRM Drive: Flexible Charging Solutions for EV/HEV Applications."
- [32] "Analysis of AC-DC Four-Switch Boost-Buck Battery Charger Converter for EV Applications."
- [33] "Four-Switch Buck–Boost Converter Based on Model Predictive Control with Smooth Mode Transition Capability."
- [34] "A Composite DC–DC Converter Based on the Versatile Buck–Boost Topology for Electric Vehicle Applications."
- [35] "Two Efficient Three-Mode Control Strategies for Four-Switch Buck-Boost Converters."
- [36] "Soft-Switching Control for a Resonant Four-Switch Inverting Buck–Boost DC/DC Converter with Wide Voltage Range."
- [37] "A Simplified Real-Time Digital Control Scheme for ZVS Four-Switch Buck–Boost with Low Inductor Current."
- [38] "A Bidirectional Versatile Buck–Boost Converter Driver for Electric Vehicle Applications."

[39] "Bidirectional Wide Range and High Voltage Gain Buck-Boost DC-DC Converter for EV Chargers Empowering V2G-G2V Applications".