



# **Investigating Cleaner Production Best Practices in Olive Oil Industry in Palestine**

**By**

**Nashaat Ziyad AL-Othman**

**Supervisor**

**Dr. Ahmed Abu Hanieh**

**Co-supervisor**

**Dr. Abdelrahim Abusafa**

**This Thesis was Submitted in Partial Fulfillment of the requirements for the Master's Degree in Sustainable Engineering in Production from the Faculty of Graduate Studies at Birzeit University, Palestine joint program with Faculty of Graduate Studies, at An-Najah National University Nablus- Palestine.**

**2019**

**Investigating Cleaner Production Best Practices in Olive Oil  
Industry in Palestine**

**By  
Nashaat Ziyad AL-Othman**

**This Thesis was defended successfully on 25/5/2019 and approved by**

**Committee Members**

**Signature**

- |  |       |
|--|-------|
| <b>1. Dr. Ahmed Abu Hanieh / Supervisor</b>      | ..... |
| <b>2. Dr. Abdelrahim Abusafa / Co-Supervisor</b> | ..... |
| <b>3. Dr. Ahmad Ramahi / External Examiner</b>   | ..... |
| <b>4. Dr. Simon Araj / Internal Examiner</b>     | ..... |

## **Dedication**

I dedicate my dissertation work to my family and many friends. A special feeling of gratitude to my loving parents, Alia and Ziyad Othman whose words of encouragement and push for tenacity ring in my ears. My brothers Ali and Hammam have never left my side and are very special and lovely sister Noor for her support and motivation. I also dedicate this dissertation to my many friends and church family who have supported me throughout the process. I will always appreciate all they have done, especially Basheer Shahan and Mohamad Abu Soad for helping me develop my technology skills and encourage me during years, Thank you all

## **Acknowledgment**

I would like to express sincere gratitude for my thesis supervisor, Dr. Ahmed Abu Hanieh, and Dr. Abdulrahim Abusafa,.For their invaluable guidance and immense knowledge throughout this research have inspired me to continue to present the research work as clearly as possible. Their constant supervision, exemplary recognition, and shared expertise have steered me in the right direction.

I would also like to thank the experts who were involved in the validation survey for this research project: Manager of Nablus Office, Ministry of Agriculture, Mr. Wajdi al Kukhn, Research Manager, Ministry of Agriculture, Dr. Ziyad Fada; Nablus Office Manager, Ministry of Environmental Affairs, Eng. Majdi Khader. The completion of the validation survey could not have been successfully conducted without their thorough involvement, dedication, and assistance.

Finally, I would like to extend my profound gratitude to my family and friends:Ali Othman, Hammam Othman , Alia Othman and Ziyad Othman for their support, and encouragement throughout my years of study and through the process of researching and writing this thesis. This accomplishment would not have been possible without them.

## الإقرار

أنا الموقع أدناه، مقدم الرسالة التي تحمل العنوان:

### **Investigating Cleaner Production Best Practices in Olive Oil Industry in Palestine**

أقر بأن ما اشتملت عليه هذه الرسالة إنما هو نتاج جهدي الخاص، باستثناء ما تمت الإشارة إليه  
حيثما ورد، وان هذه الرسالة ككل، أو أي جزء منها لم يقدم من قبل لنيل أيّ درجة أو لقب علمي  
لدى أي مؤسسة تعليمية أو بحثية أخرى.

### **Declaration**

The work provided in this thesis, unless otherwise referenced, is the researcher`s own work and has not been submitted from anywhere else, for any other degree or qualification.

**Student`s name:**

إسم الطالب:

**Signature:**

التوقيع

**Date:**

التاريخ:

## List of content

No	Content	Pages
	Dedication	Ii
	Acknowledgment	Iv
	Declaration	V
	List of Tables	Viii
	List of Figures	X
	List of Abbreviations	Xi
	Abstract	Xii
	<b>Chapter 1: Introduction</b>	<b>1</b>
<b>1.1</b>	Cleaner Production	<b>1</b>
<b>1.1.1</b>	Overview	<b>1</b>
<b>1.1.2</b>	Cleaner Production CP Benefits	<b>2</b>
<b>1.2.3</b>	Challenges in Applying Cleaner Production	<b>3</b>
<b>1.2</b>	Edible Oil Industry	<b>5</b>
1.2.1	Edible Oil Categories	<b>5</b>
1.2.2	Edible Oil Consumption and Production	<b>6</b>
1.2.3	Olive Oil Processing	<b>6</b>
<b>1.3</b>	The Olive Oil Industry in Palestine	<b>8</b>
1.3.1	Statistics on Olive Oil in Palestine	<b>8</b>
1.3.2	Sustainability Aspects and Cleaner Production for the Olive Oil Industry in Palestine	<b>9</b>
1.3.3	A Glance of the Environmental Situation in Palestine	<b>10</b>
1.4	Problem Statement	<b>11</b>
1.5	Objectives	<b>12</b>
1.6	Work Boundaries and Limitations	<b>12</b>
1.8	Significant Contribution to Research	<b>13</b>
1.9	Thesis Organization	<b>13</b>
	<b>Chapter 2: Literature Review</b>	<b>14</b>
2.1	Review of Cleaner Production Application in Industries	<b>14</b>
2.2	Resource Efficiency and Cleaner Production (RECP) Program Model	<b>15</b>
2.3	Cleaner Production Innovation	<b>16</b>
2.3.1	Cleaner Production Implantation in Industries in various Industrial Sectors	<b>17</b>
2.3.2	Cleaner Production in the Food Industry	<b>21</b>
2.3.2	Cleaner Production in Olive Oil	<b>22</b>
	<b>Chapter 3: Methodology</b>	<b>25</b>
3.1	Overview	<b>25</b>
3.2	Questionnaire Design and Structure	<b>26</b>
3.2.1	Industrial Sector Interviews	<b>27</b>

3.2.2	Governmental and Public sectors	27
3.2.3	University sector	28
3.3	Cleaner Production Methodology (CPM)	29
3.3.1	Pre-assessment Phase: Evaluation of the Olive Oil Process	30
3.3.2	Assessment (quantitative data)	31
3.3.3	Identifying Cleaner Production Options	32
3.3.4	Evaluation and Feasibility Study	36
3.3.5	Weighted Sum Method	42
3.3.6	Implementation and Continuous Improvement	44
	<b>Chapter 4: Results and analysis Cleaner Production Best Practices in Olive Oil Industry</b>	<b>47</b>
4.1	Overview	47
4.2	Cleaner production development for Olive Oil Industry	48
4.2.1	Pre-assessment phase evaluation of the olive oil process	48
4.2.2	Assessment (quantitative data)	64
4.2.3	Identifying Cleaner Production Options for olive oil industries Cleaner Production best practices for the olive oil industry	73
4.2.4	Feasibility Study	84
4.3.4	Implementation and Continuous Improvement	93
	<b>Chapter 5: Conclusion</b>	<b>96</b>
	References	98
	Appendices	109
	Appendix I: List of companies, institution and expert's response to the survey	109
	Interview- equations	110
	Appendix III: Cleaner production Options evaluation tool	123
	الملخص	ب

## List of Tables

No	Contents	Pages
Table 1	Cleaner production methodology	17
Table 2	Technical Evaluation	39
Table 3	Environmental Evaluation	42
Table 4	Evaluation of alternative option scouring metho	43
Table 5	how to assign a rank for prioritization	45
Table 6	Priority categories	46
Table 7	-Input-output analysis	57
Table 8	Olive oil Extraction Material Balance	67
Table 9	Matching causes to good housekeeping option	75
Table 10	Matching causes to Product Modification option	75
Table 11	Matching Input substation to causes	75
Table 12	Matching causes to Recycling option	76
Table 13	Matching causes to Technology Modification option	76
Table 14	Management and Personnel best practices	78
Table 15	Good housekeeping best practices	79
Table 16	waste-water minimization best practices	80
Table 17	Solid-Waste minimization best practices	81
Table 18	process optimization best practices	81
Table 19	Rising water minimization	82
Table 20	Input Material Utilization	83
Table 21	Technology retrofit options	84
Table 22	-Technical Feasibility Criteria interview results	85
Table 23	Environmental Feasibility Criteria interview results	85
Table 24	Economic feasibility accepting criteria	86
Table 25	The amount of wastewater (Zibar)	86
Table 26	The amount of solid waste generated	87
Table 27	Freshwater (used for washing and rinsing water)	87
Table 28	The amount of energy used in production as acceptable levels	87
Table 29	capability of adopting and utilizing rainwater harvesting system	88
Table 30	capability of adopting and utilizing renewable energy	88
Table 31	water treatment opportunity	88
Table 32	Environmental evaluation	88
Table 33	Olive oil Quality	89
Table 34	Human resources and staff requirement.	89

Table 35	Occupational health and safety.	89
Table 36	Product specification (color, taste, Ph number).	90
Table 37	Easy installation and implementation	90
Table 38	Time needs for implementation.	90
Table 39	social aspects	90
Table 40	Technical Evaluation	91
Table 41	payback period (PBP)	91
Table 42	Technical evaluation	92
Table 43	Environmental evaluation.	92
Table 44	Feasibility weighting	94
Table 45	how to assign a rank for prioritization	94

## List of Figures

No	Contents	Pages
figure 1	cross-section of the olive fruit	7
figure 2	resource efficiency and cleaner production concept	15
figure 3	input-output model and relative cp technologies of stone processing industry	18
figure 4	alternatives for the reduction of voc emission	19
figure 5	cleaner production implementation in the textile sector: the case of a medium-sized industry in minas gerais	21
figure 6	process flow for olive oil operation, a) three-phase production, b) two-phase production	24
figure 7	general methodology	25
figure 8	cleaner production methodology	29
figure 9	cause-diagnosis adopted from	32
figure 10	eco-design strategy wheel adopted from	35
figure 11	cleaner production options evaluation flow-chart	35
figure 12	olive oil production process (process flow chart)	37
figure 13	key for process flow chart	49
figure 14	current disposal methods in palestine	50
figure 15	wastewater characteristic	54
figure 16	eco map key	56
figure 17	traditional pressing mill eco-map	58
figure 18	three-phase decanter mill eco map	59
figure 19	two-phase decanter eco map	61
figure 20	material balance for extraction technology in mediterranean area	63
figure 21	material balance for extraction technology in palestine [35]	66
figure 22	material balance for extraction technology in Palestine	67
figure 23	solid waste causes	73
figure 24	energy losses causes	74
figure 25	WASTE-WATER CAUSES	74
figure 26	cleaner production options for olive oil industries	77

**List of Abbreviations**

<b>CP</b>	Cleaner Production.
<b>CPA</b>	Cleaner Production Assessment.
<b>UNEP</b>	United Nations Environment Program.
<b>UNIDO</b>	The United Nations Industrial Development Organization.
<b>NCPC</b>	National Cleaner Production Center.
<b>RECP</b>	Resource Efficient and Cleaner Production.
<b>GDP</b>	Gross Domestic Product.
<b>HACCP</b>	Hazard Analysis and Critical Control Points
<b>CMY</b>	Cubic Meters per year.
<b>OMW</b>	Olive Mill Waste.
<b>OMWW</b>	Olive Mill Waste Water.
<b>TPOMW</b>	Two-Phase Olive Mill Waste.
<b>COD</b>	Chemical Oxygen Demand.
<b>BOD</b>	Biological Oxygen Demand.

**Investigating Cleaner Production Best Practices in Olive Oil Industry  
in Palestine**

**By**

**Nashaat Ziyad AL-Othman**

**Supervisor**

**Dr. Ahmed Abu Hanieh**

**Co-supervisor**

**Dr. Abdelrahim Abusafa**

**Abstract**

Cleaner production techniques were adopted to develop the best practices of the olive oil extraction process industry in Palestine. The needed data were collected through a data collection tool “questionnaire.” This questionnaire was designed to be consistent with the used technologies in the Palestinian olive oil extraction processes, the data was then collected through interviews and brainstorming sessions with the stakeholders, after that the data was analyzed and evaluated according to the different analytical tools to generate the best practices (options) of cleaner production opportunities related to this industry.

Based on the interviews and walkthrough with stockholders, the olive mills in Westbank general characteristics of OMW, and material balance analysis for input and output material, it was concluded that an environmental management system is needed to manage the OMW in Palestine. Different cleaner production options have been presented and elaborated. An evaluation tool was developed to grade and rank cleaner production options

to seat the priority for implementation. The management and treatment option should be environmentally friendly to reduce or eliminate the OMW; the olive-mills management system has been analyzed from harvesting to end-of-pipe.

A comparison between olive oil extraction was made, three-phase decanter the most popular in Palestine; due to mass production and acceptable quality, the environmental impact not considered and important for many. Two phase decanters in Palestine Not desirable; due to high investment cost and expensive disposal of by-product and wastes.

**Keywords:**

Cleaner production techniques, Olive Oil Extraction Processes, Tow-phase Decanter, Three-phase Decanter, cleaner production options, Waste reduction, good housekeeping.

# **Chapter 1**

## **Introduction**

### **1.1 Cleaner Production**

#### **1.1.1 Overview:**

Cleaner production (CP) was defined by the United Nations Environment Program (UNEP) in 1990 as “The continuous application of an integrated environmental strategy to processes, products, and services to increase efficiency and reduce or eliminate risks to humans and the environment” [1].

The concept was created during the global training in the 1990s through Conference on Ecological Sustainable Industrial Development in Copenhagen, The United Nations Industrial Development Organization (UNIDO), the United Nations Environment Program (NEP), and the United States Agency for International Development (USAID) discussed the importance of resources in the world. These organizations concluded that the industries should be more sustainable in production, taking into consideration future generations. They agreed to put a strategy for the worldwide promotion of cleaner production by UNIDO, which adopts the UNEP definition of cleaner production. [2]

To start promotion for cleaner production concept, UNIDO planned to open five centers for cleaner production named by National Cleaner Production Center (NCPC) in 1994, distributed in China, India, Mexico, Tanzania, and

Zimbabwe. They started their work in 1995, where each country worked upon the need for a specific agenda. In 2004, two countries were added to the program; the Czech Republic and Slovakia [2].

In 2009, an evaluation of the program was performed. Subsequently, the results made the title of the program more accurate: Resource Efficient and Cleaner Production (RECP). In terms of conception and thermal sciences, the scope of cleaner production was expanded to cover the three dimensions of sustainability; focused on natural resources use during production (water, material and energy), cost reduction, reduced generation of wastes, effluents and emissions; improved protection of health and well-being of employees, consumers and society [2].

By 2014, the UNIDO-UNEP RECP Program has existed as a National Cleaner Production Center. This Center carries out numerous activities within fifty-eight centers in fifty-six locations in different countries: 11 in Asia, 13 in Africa, ten in Latin America, 19 in Europe and five in the Middle East and North Africa [2].

### **1.1.2 Cleaner Production CP Benefits:**

The benefits of cleaner production could be summarized in the following items:

- 1) Reduction in greenhouse emissions, waste, and pollution

- 2) CP improving the efficiency of product, production, and process (water, energy, material use, and reuse of productive resources)
- 3) CP minimizing the potential of risk (human, occupational, and environmental)
- 4) Opening new markets and competitive improvement (open a greenmarket)
- 5) Organization reputation enhancement and trust-building with their stockholders
- 6) Organization revenue will increase, leading to a more competitive price in the market
- 7) Improvement in work condition such as increased job satisfaction and improvement in worker qualification and motivation
- 8) Improvement in product quality and safety for the end-user

Keep up to date regarding new technology and improvement in the world [3].

### **1.2.3 Challenges in Applying Cleaner Production:**

The challenges of the implementation of cleaner production could be summarised in the following items:

- 1) Lack of sustainability criteria and guidelines from governments or organizations

- 2) Documentation system and records are keeping for the system inside the organization that gives us a precise fewer data for the current situation regarding waste quantity, energy bills
- 3) Lack of human, financial and technological resources
- 4) Lack of cleaner production implementation projects in industries
- 5) Lack of incentives and motivational tools by governments and other related agencies such as UNEP for applying cleaner production techniques in specific industries
- 6) Short-term investment
- 7) Poor of strategic planning
- 8) Lack of participation and commitment from all employees
- 9) Conflicts between stockholders
- 10) Errors and problems appearing in the active communication system
- 11) Absence of specific structured methodology for analysis and implementation of Cleaner Production
- 12) Increased complexity of performing operations
- 13) Absence of an “environmental-friendly” culture (on a business and social level, including the difficulty in seeing the benefits of Cleaner Production)

14) Difficulty in receiving market feedback [3]

## **1.2 Edible Oil Industry**

Edible Oil was defined by the Government of Ontario, Canada as "a food substance, other than a dairy product, of whatever origin, source or composition that is manufactured for human consumption wholly or in part from a fat or oil other than that of milk." [4]

Edible oil is also called plant-based oils. The structure of edible oil could be solid or liquid at a specific room temperature. The chemical structure of the edible oil that is derived from the plant consists of carboxylic acids with long hydrocarbon chains, knowing that the carboxyl group makes the oils edible. [4].

### **1.2.1 Edible Oil Categories [4] :**

Edible oil can be divided into three broad categories:

1) Structured oil: the structure is solid at room temperatures such as margarine or Ghee.

This kind of edible oil is considered unhealthy because it can cause high levels of cholesterol and heart diseases.

2) Monounsaturated oils: the structure of this category is liquid at room temperature. It is solidified in the refrigerator or at low temperatures such as olive oil and peanut oil.

3) Polyunsaturated oils: the structure is liquid at room temperature. Even at low temperatures, it remains liquid such as sunflower oil, corn oil, and others [4].

The most commonly consumed edible oils are: coconut oil, corn oil, cottonseed oil, olive oil, palm oil, peanut oil, rapeseed/canola oil, safflower oil, sesame oil, soybean oil, sunflower oil, ghee and Niger edible oil.

### **1.2.2 Edible Oil Consumption and Production**

The Food and Agriculture Organization of the United Nations (FAO) reported that the global consumption of edible oil increased by 48% between 1995 to 2011, which gives an indicator of the importance of edible oil in the food chain for the consumer [5].

The oilseeds are the raw material for oil production. The top five countries that produce the seeds of edible oil are the following arranged in a descending manner: The United States of America, Brazil, Argentina, China, India [6].

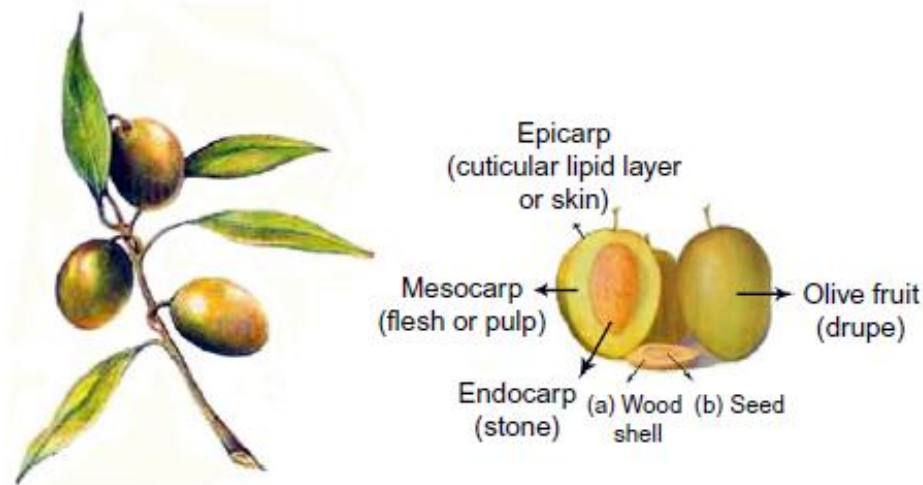
The global average consumption per capita is 15 kg/year, while the World Health Organization (WHO) recommends 20–25 kg/year per capita [7].

### **1.2.3 Olive Oil Processing**

Olive drupe is the main ingredient in olive oil production; the second primary ingredient used is water needed for cleaning and processing the drupes. The following sequence shows the production steps:

- Olive drupes received by the Quality assurance department to make sure that it matches the required standards in terms of color, size, and shape.
- Washing and cleaning olive drupes in private water pools. Leaves and light impurities are removed by applying vacuum pressure.
- Grinding and crushing olives using grinding stone mills or hammer mill.
- Paste separation: separating the olive oil from liquid (zibar) and solid waste (pomace).
- Purification and refinement as a final step to produce pure oil [7].

Figure 8 illustrates the cross-section of the olive fruit.



**Figure 1:** Cross-section of the olive fruit. [8].

### **1.3 The Olive Oil Industry in Palestine**

The food processing sector in Palestine is continuously growing due to the vast range of products, such as vegetables (fresh and frozen), oils and fats, dairy, flour mills, animal feeds, water and soft drinks, chocolates, and confectionaries and others [9]. The total contribution of food processing to the Palestinian GDP is 4.8% for the West Bank and Gaza strip with 224 firms working inside Palestine [9]. There is a high orientation for many firms in Palestine to go with Quality assurance certificates such as Palestinian standard and ISO 22000 (food safety management system HACCP) [9]. Regarding Automation and using new technology, the sector has a high production capacity but not fully utilized, and does not use new technology due to high investment cost. The sector has many links to other industrial sectors in Palestine, such as the plastic industry, chemical, printing, and packaging [9]. An average Palestinian family consumes up to 42% of its monthly income on food basket relative to other living expenses, which give an indicator of the importance of this sector in Palestine [9].

#### **1.3.1 Statistics on Olive Oil in Palestine:**

The sector in Palestine is known as oils and vegetable fats. There are thirteen factories specialized in producing oils and vegetable fats. The number of working forces inside the plants is 295 employees; the capital investment in this industry is estimated to be 70 Million dollars. Regarding olive oil mills in Palestine, we have 274 mills distributed between cities and villages with 246 mills in the West Bank and 28 mills in the Gaza strip

[10]. This product contributes to 20% of the market share from all the food sector. Only three of these factories succeeded to receive ISO 22000 Food safety management system certificate, and ten of them received HACCP certification. Furthermore, this industry contributes to 31 million dollars of the value of the exports. The olive oil industry still needs more promotion and tools to be expanded worldwide. [11]

Many products are exported to Arab countries from Palestine and worldwide; the most popular product is olive oil. [9]

In Palestine, olive oil has a high rate of contribution to the food sector, about 19.61% of the total output. Besides, the exports to other countries reach 39.2 million Dollar in 2015. The production, distributed as 30% consumed in the local market, and 70% are exported worldwide [12].

### **1.3.2 Sustainability Aspects and Cleaner Production for the Olive Oil Industry in Palestine**

Agricultural products are the primary input of the edible oil industries, especially seeds. In Palestine, some companies produce olive oil, while other companies produce fats such as Ghee. However, due to the high competition, nowadays, they import it as a private label and add some processes to it, such as assembly and packaging.

### 1.3.3 A Glance of the Environmental Situation in Palestine

**Land:** the agricultural production is divided as 31.7% cultivated in the West Bank and 47.8% cultivated in Gaza Strip. Its contribution to the Palestinian GDP is between 22 through 30%. There is limited regulation from the Palestinian Authority regarding sustainable land usage [13].

**Water:** considered the rarest source in the region. Due to the Israeli occupation in Palestine, there are constant restrictions on water usage of groundwater by Palestinians as the supply is a limited quantity. The estimated water consumed in Palestine is 107-156 cubic meters per year (CMY). Palestinian consumption of water is mainly for agricultural usage. On the other hand, water consumption in other sectors is minor between 35-50 CMY, the Palestinian demand per capita is estimated as 125 CMY. Palestinian consumer pays \$1.2 per cubic meter of water [13].

**Air:** Air Quality in Palestine is assumed at an acceptable level compared to other countries. However, it is soon expected to be more alarming due to the increase in industrial sectors and cars' usage in Palestine [13].

**Waste Management:** this resource is well-known in Palestine as no net income value. The bad management of this waste could be harmful to water resources and land utilization. The solid waste produced in Palestine is estimated to be 275,000 tons generated annual in the urban area, usually landfilled or dumped randomly; 65 % of this waste is organic. [13].

*Pollution from Industrial Activities:* the contribution of industry in Palestinian GDP is estimated to be 15.7% for the year 2013. The bad management of waste in an inefficient way leads to pollution of the environment. Furthermore, prolonged exposure to polluted air and water causes chronic health problems [14] .

In the Mediterranean area, we found an essential statistic about 20 million tons of freshwater is needed for olive oil; Output is up to 30 million tons of solid-liquid waste (orujo and alp orujo) per year [15].

#### **1.4 Problem Statement:**

The demand for food will increase as long as the population in Palestine increased. Thus, the food sector needs to be more sustainable in using raw materials. As an occupied country, Palestinians do not have access to water and energy, and it costs more than the neighboring countries due to Israeli regulations. The food sector needs to focus on resource efficiency and quality assurance to improve the current situation. The current technology used in the olive oil extraction process generates many environmentally harmful products, such as wastewater (Zibar) and solid waste, such as Pomace. Applying cleaner production (CP) practices are capable of reducing the negative environmental impacts of these processes while keeping the high quality of olive oil at a reasonable cost.

### **1.5 Objectives:**

The objectives of this work are:

- 1) To investigate the best Cleaner production practices in the olive oil industry worldwide.
- 2) Investigate the benefits of applying suitable cleaner production practices to the Palestinian olive oil industry through:
  - a- Interviews with field experts and a semi-structured questioner.
  - b- Selection and sieving of relevant indicators from previous studies.
  - c- Analyzing the obtained data through benchmarking with international standards.

### **1.6 Work Boundaries and Limitations**

In this thesis, the resource efficiency model had built for the olive oil industry by applying the cleaner production technique on it. The study will be limited (applied) to the West Bank.

The limitations faced while implementing this research are the following:

1. Lack of previous Cleaner Production research or study in Palestine for this sector and any sector.
2. Limited availability of experience in the cleaner production and sustainability field.

3. Lack of scientific qualifications in the oil industry.
4. Shortage of using modern machinery and technologies.

### **1.8 Significant Contribution to Research:**

The implementation of Cleaner Production techniques in this research is expected to:

- 1) Offer sustainability concepts to the Food industrial sector in Palestine specifically the olive oil sector; by suggesting Resource Efficiency Model (REM) improve the industry to be cleaner and more sustainable, by suggesting new methods in manufacturing (packaging, reduce consumption of resources by using renewable energy sources).
- 2) Lead to cost reduction and access to new markets; thus increasing competitiveness.
- 3) Add value to worldwide research to be the first model in the Olive Oil industry.

### **1.9 Thesis Organization**

The thesis is organized as follows; the first chapter furnishes essential information regarding the problem background and the motivation behind carrying out the work. Literature review took place after introduction; the methodology is elaborated in chapter three, while cleaner production in edible oil industry implementation is provided in chapter four, while the conclusions and recommendations are provided in the last chapter.

## **Chapter 2**

### **Literature Review**

#### **2.1 Review of Cleaner Production Application in Industries**

Cleaner production could be applied in different research issues in many industries as a strategy, such as an efficiency improvement through natural resources; or so-called resource efficiency, waste reduction, pollution and risks minimization at the source where they are generated. Furthermore, it is an essential part of any environmental management system [16].

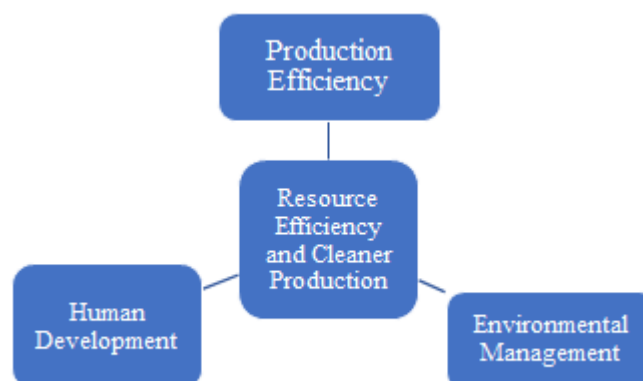
There is a lack of awareness level in enterprises regarding the environmental impact of business activities. Moreover, studies show that institutions tend to underestimate the environmental impacts of their business, without any specific data or research concerned with environmental impact or production efficiency. The institution will not go with cleaner production implementation or take any action that will improve environmental performance [16].

Cleaner production could be applied in many industries in the production process to conserve raw material and energy use in processing and reducing the number of toxic emissions and waste before they leave the process. It could be applied in production processes by reducing the impact of the product life cycle from raw material to the final disposal. Finally, it could be applied in services through preventive approach and good housekeeping such as in hospitals, hotels, and banks [16].

## 2.2 Resource Efficiency and Cleaner Production (RECP) Program Model

Cleaner production strategy focuses on creating a systematic assessment of waste/pollution generation caused through well-developed procedures, and practical options and solutions to minimize or eliminate the source of pollution or other related problems. On the contrary, other concepts such as eco-efficacy, waste minimization, and pollution prevention have the same strategy that works to reduce or eliminate the problem from its root. [17].

The primary purpose of applying the techniques of CP is to avoid or reduce waste produced during the production life cycle by using energy and resource efficiency—called production efficiency. Producing environmentally friendly products or services is called Environmental Management. Besides, the process of generating less waste that reduces or eliminates the cost and human health and safety reduce the risk of people and increases the profits is called human Development Fig 1 [17].



**Figure 2:** Resource efficiency and cleaner production concept [source 14].

Cleaner production could be applied in any industry and service sector such as manufacturing products, through three principles. The first principle is Precaution which focuses on the system management in a sustainable way, the inputs of human resources or raw material that should be well designed to reduce or eliminate damages and impact of this approach at the beginning of planning or designing the system. The second principle is Prevention, known as a modification during the production level. Activities are carried out in the industry to reduce any harm from a well-known process such as using an eco-friendly technology for water consumption or energy consumption, and it is in the level of product or service that is directly used by the end-user. The third principle is Integration, which represents the life cycle analysis for the product [14].

### **2.3 Cleaner Production Innovation:**

Through assessing the literature review on how to implement cleaner production in industries, cleaner production assessment methodology was found as the essential method to implement cleaner production techniques in any industry. Cleaner production assessment is defined as all activities that aim at identification, evaluation, and implementation of cleaner production opportunities in the specific industry [18].

Cleaner production assessment is defined as the systematic approach to identify the source of waste and eliminate or reduce it [14].

Hence, cleaner production methodology in any industry should be illustrated, as shown in Table 1 .

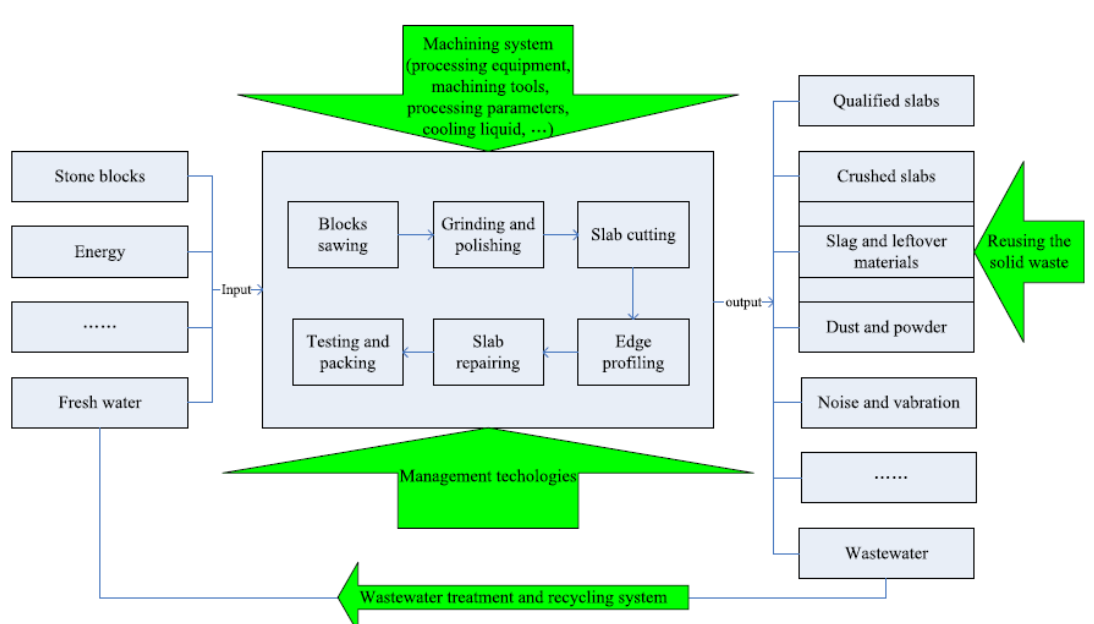
**Table 1 Cleaner production methodology [15, 16,19]**

Phase	Stages
1- Planning and organization	1- Obtain management commitment. 2-Establish project team. 3-Develop policy, objectives, and scope of work. 4-Plan the cleaner production assessment.
2- Pre-assessment (qualitative review)	5-Company description and process flow chart 6- Walkthrough -inspection Evaluate input and output 7-Establish a focus (room for improvements)
3-Assessment (quantitative review)	9- Material Balance 10- Identify cleaner production opportunities 11-Record and sort options
4- Feasibility study	12- Preliminary evaluation 13- Technical evaluation 14- Economic Evaluation 15-Enviromintal evaluation 16- Selection of feasible option
5-Implementation and continuous improvement	17- Prepare CP plan 18-Implement feasible options 19- Monitor CP progress 20- Sustain CP.

### **2.3.1 Cleaner Production Implantation in Industries in various Industrial Sectors:**

In China, the rapid increase in economic and development was found. Due to urbanization consequences, people tend to increase the demand in stone that caused an environmental problem as a result of bad management in stone processing to solve that issue, as shown in Figure 2. They started to use a cleaner production evaluation model; this evaluation model gives a chance to decision-makers to quantitatively evaluate the effectiveness of CP in the stone processing industry. The evaluation model focuses on three

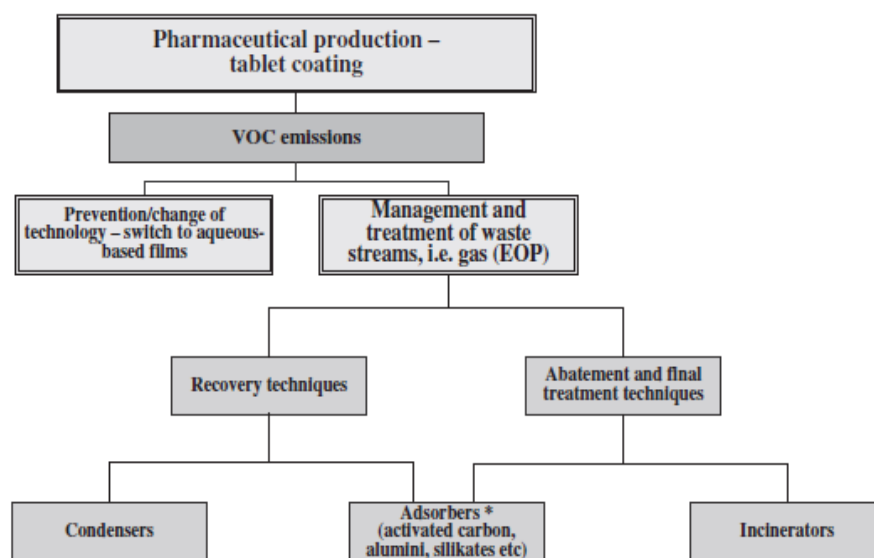
main frameworks in which they put six primary indicators and 24 sub-indicators used in the evaluation. These indicators came from the stone production process, laws, rules, and regulations in China, taking into consideration the CP level in the country. Finally, in order to evaluate the weights of each indicator, they used an analytical hierarchy process and fuzzy membership degree analysis. In order to ensure that the revaluation model is visible, a verification process had been made on the local plant as a case study to evaluate the model [19].



**Figure 3:** Input-output model and relative CP technologies of stone processing industry [17]

Furthermore, cleaner production is applied in industry to find a solution to reduce the emissions in the air, exceptionally high toxic to humans such as a study made in the pharmaceutical industry shown in Figure 3. To be more specific in tablet coating processing, the main goal of this study is to show

how we can move beyond pollution control by technology improvement and prevention of organic solvents emission in the atmosphere. The study benefits from altering the technology through cost analysis of alternatives, and the saving will be made after adopting the new technology in producing film-coated tablets. In the study, they provide some evidence and analysis to avoid the use of organic solvents from film-coating systems in the production of the pharmaceutical solid dosage forms [20].

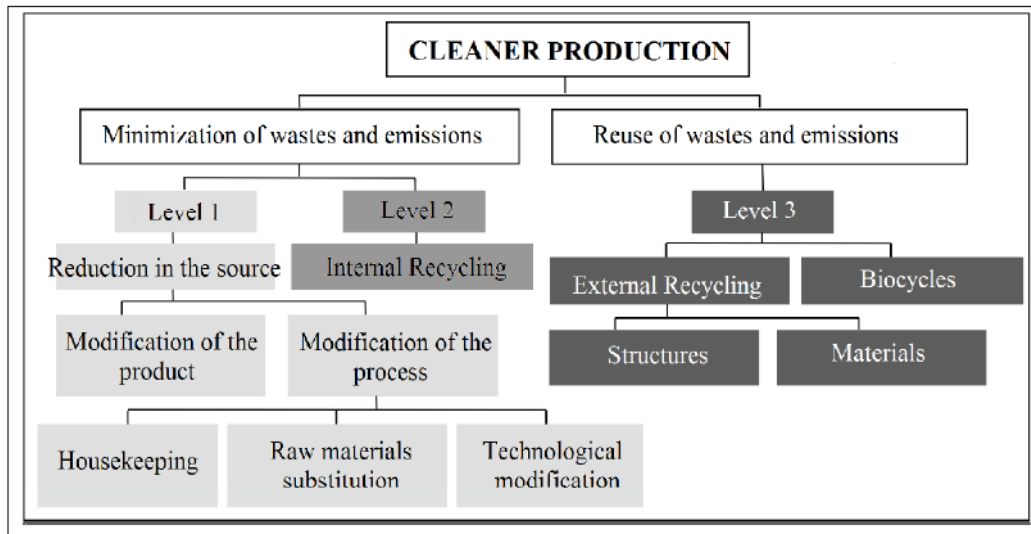


**Figure 4:** Alternatives for the reduction of VOC emission. [18]

Cleaner production plays an important role which can be useful to be implemented in the service sector and reflected as an opportunity to increase the profit and reduce the production cost. The service sector, such as hotels, aims to keep the customer satisfied where a suitable environment is needed. Thus, hotel management should keep the temperature level suitable inside rooms. Also, it is essential to keep the source of water

available for use in suitable temperatures and a considerable amount of energy; to keep the quality as expected. For these reasons, cleaner production could be useful as found in a study made in Hotel Manoluck - Luang Prabang by UNIDO as they take into consideration water and energy consumption and waste produced from food. They found good housekeeping in the hotel—adopting a new technology to control the temperature of rooms, which will save a lot of money and save the environment at the same time [21].

Furthermore, the Textile industry is assumed to be an essential sector in many countries, including Brazil. Research had been done for cleaner production implantation in the textile industry with a case study in Brazil. The methodology for this research adopted from CP methodology, as they start by developing an evaluation tool to assess the current situation in the industry from a literature review called checklist. Following this step, the data is then collected from field visits, and interviews made a field survey. The study showed a cleaner production opportunity for this industry and highlighted a recommendation for improvements as feasible actions. The conclusion after implantation in the case study found that cleaner production can consist of environmental benefits and economic benefits for this industry [22].



**Figure 5:** Cleaner Production Implementation in the Textile Sector: The Case of a Medium-sized Industry in Minas Gerais [20]

### 2.3.2 Cleaner Production in the Food Industry.

CP methodology had been applied in many fields of food industries in the world to solve environmental problems and to carry out the production process in a more sustainable way, such as in chicken slaughtering plant. A study was made in Malaysia, focusing on making the process more sustainable and safer for employees' health, so they provide an assessment tool for the production process. The primary purpose is to reduce the risk and negative impact of the production process on the environment through reducing carbon dioxide emission and taking into account five leading indicators: fuel consumption, electricity and water consumption, wastewater generation and solid waste. The methodology contained direct observation and walkthrough process, review of relevant documents, and site inspections. The results concluded that the highest consumption rate

from carbon dioxide came from electricity. For this reason, they proposed a new option to reduce electricity and made a feasibility study to apply it in the industry [23].

Furthermore, UNEP had made two CP guides for meat, while fish processing and cleaner production algorithm had adopted five steps, as mentioned in table 1 [24].

### **2.3.2 Cleaner Production in Olive Oil**

Cleaner production could be implemented in the edible oil industry. A research was made in Egypt, of which methodology adapted from the CP algorithm, where they focus on four main parameters: water consumption, energy consumption, solid waste generated, and chemical used in production. They developed cleaner production options for the industry, including water reuse and recycle techniques, good housekeeping, best practices for it proposes adopting new technology such as using solar energy [25].

Moreover, a study was conducted for the implementation of cleaner production techniques in the palm oil industry. This study aimed at showing cleaner production options for this industry by proposing various options and making a feasibility study for it; thus, the cleaner production methodology had been adopted. Palm oil contains phytonutrients such as carotenoids, sterols, squalene, and many others. They have significant benefits for humans during processing many of these components to lose

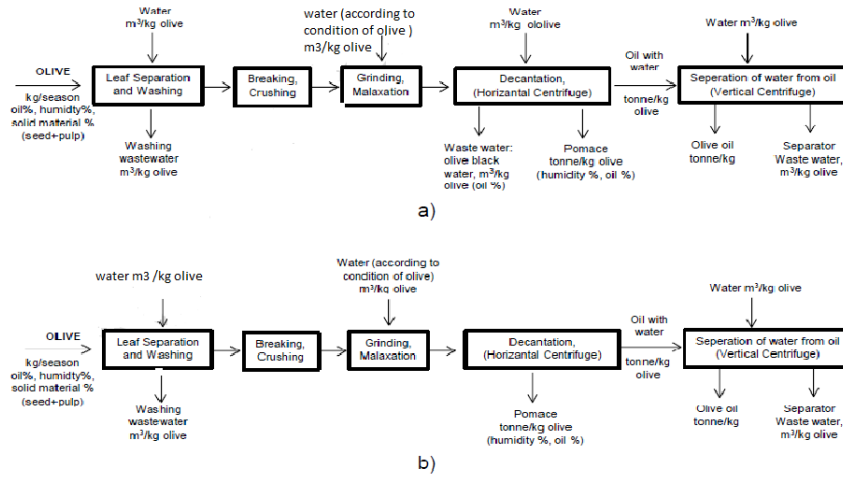
their nutritional value during processing from heat and air. This study is aimed at adopting new technology to save the nutritional value of palm oil. In conclusion, it proposes two new technologies: Supercritical fluid extraction and short path distillation and makes a comparison with the old one [26].

A research was made by Rudina Çakraj about resource efficiency and cleaner production in the olive oil industry in Albania. Olive mill waste generated (pomace and zibar) management was the focus area CP techniques were implemented.

The conclusions were to improve information management system inside the institution, reduce water consumption, improve the quality of olives, process modification by installation of the second centrifuge in the oil cleaning process, process the pomace to be used as fuel (drying and pressing of the pomace), and treatment of wastewaters before discharging into municipal sewage system (optional treatment system “reed bed system” or “constructed wet-land”). [27]

A study was made in Turkey about olive oil technology modification through mass balance. A case study had been taken to illustrate the cleaner options they have, for the olive oil extraction process. They found a varied between input raw material on sit recovery and reuse, including equipment modification and technology change. Furthermore, a mass balance calculation took place through input and output analysis of water

consumption and oil, pomace, and wastewater generation. A definition of objective and process description had made, as shown in figure 6 [28].



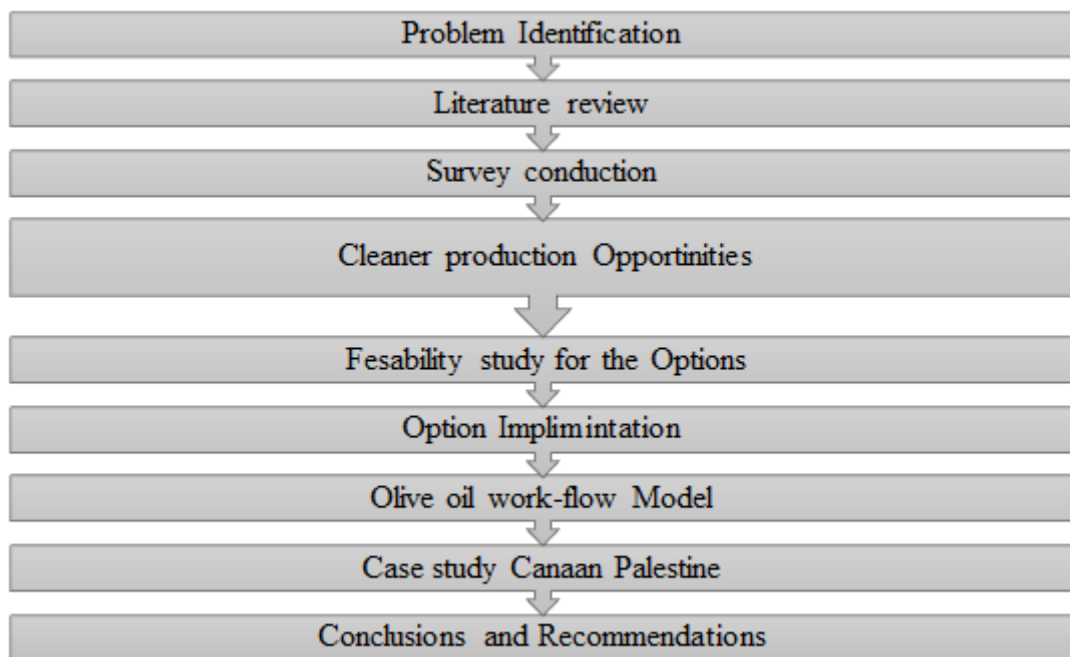
**Figure 6:** Process flow for olive oil operation, a) three-phase production, B) two-phase production [28].

## Chapter 3

### Methodology

#### 3.1 Overview:

This chapter illustrates and explains the methodology used in this research. As seen in figure 7, the methodology starts with an identification of the research problem. The necessary data regarding cleaner production best practices in the olive oil industry were gathered through conducting a detailed literature review, followed by designing a semi-structured questionnaire conducted with interested parties.



**Figure 7:** General Methodology

### **3.2. Questionnaire Design and Structure:**

The questionnaire was developed according to different criteria; these criteria were derived from different related sources such as literature review, ISO 14,000, local regulations, and self-observation.

The boundaries of the work started from harvesting the olives drupes to the disposal of waste. Based on that, the questionnaire is distributed in three main sectors, which are industrial sector, governmental, and academic.

The interviews were conducted through five multi-part questions that took approximately thirty to forty-five minutes to complete. The purpose of the first part is to gather general information about cleaner production practices applied in the targeted sectors. The focus areas of the questionnaire are about the consumption of water, energy, materials, pollution, and the environmental impact. These dimensions were adopted as the variable parameters of the olive oil extraction process. The focus area on water uses and cost in rinsing water, washing water, and water used in the production process. The second focus area was about energy cost and renewable resources used inside the factory; such as PV units and using pomace as an energy source for water heating. Finally, the last focus area on pollution and the environmental impact was regarding the disposal methods and cost of wastes such as, solid waste (pomace), wastewater, and Zibar. The questioner was useful in developing cleaner production options and indicators to develop the best practices in the industry.

### **3.2.1 Industrial Sector Interviews:**

Eight companies were interviewed; they are producing olive oil with different extraction techniques. Four companies are using new technology for olive oil extraction two, and three-phase decanter, one of them is using the traditional olive oil pressing mill method, and three companies are producing besides the olive oil other products such as ghee and almonds.

The interviews focused on the desired dimensions to assess the current situation of the production process—What practices they adopt during the production process, from receiving the raw material to produce the final product and by-product, the methods of disposing of the OMW, where what, and how to handle the OMW.

Furthermore, the economic aspects of handling the OMW took place; to conclude the best options on how to reduce the cost of disposal and the impact of adopting new techniques to increase the profit.

### **3.2.2 Governmental and Public sectors.**

Three central institutions and authorities involved in the sectors which were interviewed; including the Ministry of Environmental Affairs, Palestinian Authority of Agriculture, and Palestinian Olive Oil Council. The main scope of these interviews was about the regulations and standards customized to these sectors. Open-ended questions were used, such as the research and development activities, by the Palestinian Ministry

of Agriculture and Ministry of Environmental Affairs, the level of contribution; to increase the awareness between interested parties. If there are any solutions or best practices directed to the factory's owners and farmers. Finally, regarding environmental issues, the main focus on OMW management issues and the level of harmless that resulted from the improper disposal of the waste and recommendation solution also, the direct and indirect cost for improper OMW disposal and the economic and environmental benefits if there is an investment in improving the disposal methods to be eco-friendlier.

### **3.2.3 University sector:**

Two universities were included to cover the academic sector: An-Najah National University and Bitzit University. The main scope of these interviews was about research and scientific papers published in this field, the collaboration between the academic sector and private sector regarding the olive oil industry, the potential solutions, and the best practices recommended to the government and private sectors.

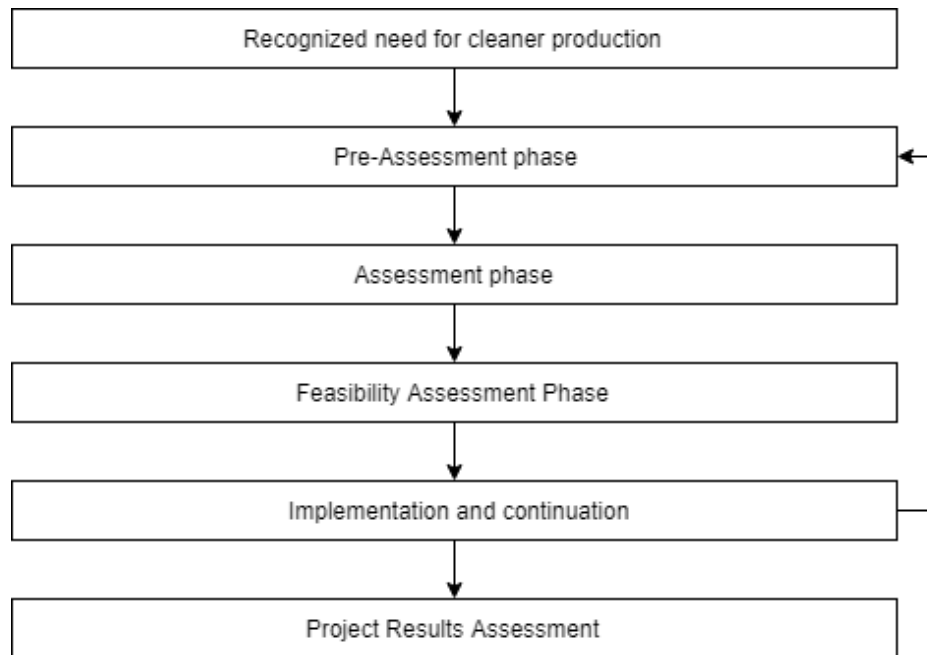
Furthermore, the indicators and best practices were verified during the interviews.

In the Appendix, more information is provided to show the list of conducted interviews

In Appendix (II), more information is provided for a full list of questions included in the questionnaire.

### 3.3 Cleaner Production Methodology (CPM)

Cleaner production methodology was adopted from a manual developed by UNEP, UNIDO; namely, “How to Establish and Operate Cleaner Production Centers” as a systematic approach as shown in Figure 8 [29].



**Figure 8:**Cleaner production Methodology [30].

### **3.3.1 Pre-assessment Phase: Evaluation of the Olive Oil Process**

The pre-assessment phase aims at understanding the olive oil processes' sequencing and procedures to identify cleaner production opportunities and options in the next phase, taking into account the kind of data which will be based on the qualitative approach.

During the study, the following tools were adopted from a guidance manual developed by UNIDO, UNEP: "How To Establish And Operate Cleaner Production Centers part 4" [30] during the implementation of pre-assessment phase, four main steps were followed :

1) Collecting necessary data for the olive oil production process in the Mediterranean region generally and in Palestine particularity, to develop a process flow diagram and eco-map of the site as output. The process flow diagrams start with

the harvesting process and end with the disposal process. Furthermore, each operation process was described as a block diagram; that illustrates detailed information about input and output for each step.

2) Conducting a walkthrough: verification process was conducted using the developed questionnaire a walkthrough production line, inventory rooms, boiler rooms, water resources, energy resources, and waste disposal areas, were made during field visits for more than eight working olive mills in the West Bank.

### 3) Preparing an eco-map :

Eco-map is a tool used to illustrate the used water and energy, in addition to the waste disposal inside the plant. It shows the efficiency of operation and environment performance.

### 4) Carrying out preliminary material and energy balances.

It is an essential inventory management tool. It presents a clear view of the resources used “what goes in must come out somewhere”.

In this research, a unit of 1000 kg (one Ton) of olive drupes was taken as a basis. The water and energy consumption and waste generation were calculated during the production per unit ton of olive drops. The data of these quantitative numbers were taken from Middle East consumption study and local studies from Palestine. A block diagram and tables were used to show the results.

## **3.3.2 Assessment (quantitative data)**

### **3.3.2.1 Material Balance:**

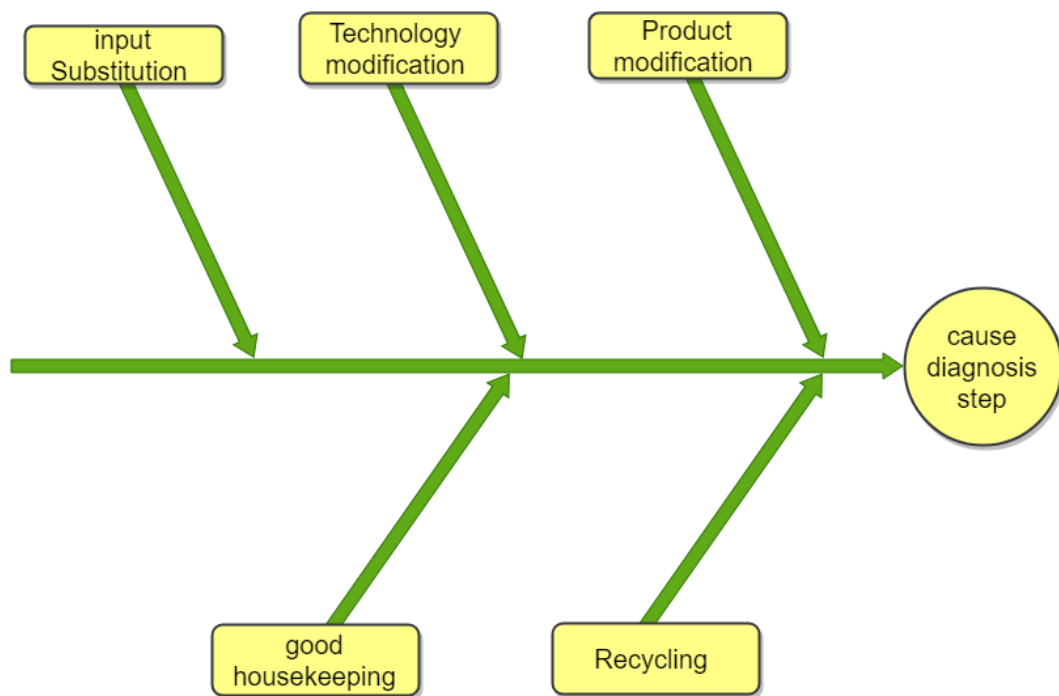
The assessment phase aims to calculate the qualitative data of raw materials, energy and water consumption, wastewater, solid waste, and/or any other by-product generation in the olive mill extraction process.

A study was conducted by the Centre of Cleaner Production (RAC/CP) in the Mediterranean area. Consumption rates in Palestine and Israel were taken into consideration in the study, which gives us an indicator of the

OMW rate in the area of study. The material balance was also developed upon this data. The olive oil extraction with three different extraction techniques was compared in terms of the aforementioned consumption and generation. [31].

### 3.3.3 Identifying Cleaner Production Options:

As shown in Figure 9, the cleaner production assessment phase starts with making a general “diagnosis” of the process to identify the shortcomings and their causes, as well as to find options for how to improve it.



**Figure 9:** cause-diagnosis adopted from [32].

- Cause diagnosis through the fishbone diagram

This tool is used to identify the causes of producing OMW.

The cause divided into five categories; this category has a direct impact on the leading cause of overall environmental impact during manufacturing.

- Input substitution: How does the choice and quality of input material affect the waste generation and the overall environmental impact of the process?
- Technology modification: How does the selection of technology and design of equipment affect the waste generation and the overall environmental impact on the process?
- Product modification: How does product specifications affect the waste generation and the overall environmental impact of the process?
- Recycling: Do waste streams contain valuable components, such as input material of intermediate or the final product?
- Good housekeeping: How do equipment operation and maintenance procedures affect the waste generation and the overall environmental impact of the process?

OMW is the main output of the olive oil production process, and it was the focus area in the study. Furthermore, the causes were adopted from UNEP/DEPA manual 2000, which are Input Substitution, technology modification, product modification, good housekeeping, and recycling.

The following questions were asked during the interviews: how much water used in this process, “How/where you deal with the OMW,” “why did such a problem or outcome occur?”, “why this technique used”? the root causes of the problem were known and summarized in chapter 4.

- Prioritizing the causes identified in the fishbone diagram:

After defining the causes that produced the amounts of OMW, the extent to which each particular cause contributes to OMW was analyzed in chapter 4 the analysis was conducted by field visits observations, historical records inside the olive mills, and literature review to eliminate a specific secondary cause.

- Cleaner production option generation through brainstorming:

After identification, the leading causes of option generation phase was conducted to develop cleaner production options in the olive oil industry. The primary reference was interviews with experts in the fields using questionnaires and previous studies .The following questions were asked: "how OMW could be reduced effectively?"; “do we have any alternative to this technology in Palestine,”; “Is it valid options.” Figure 10 shows one of the tools used to generate cleaner production options using the Eco-design Strategy wheel.

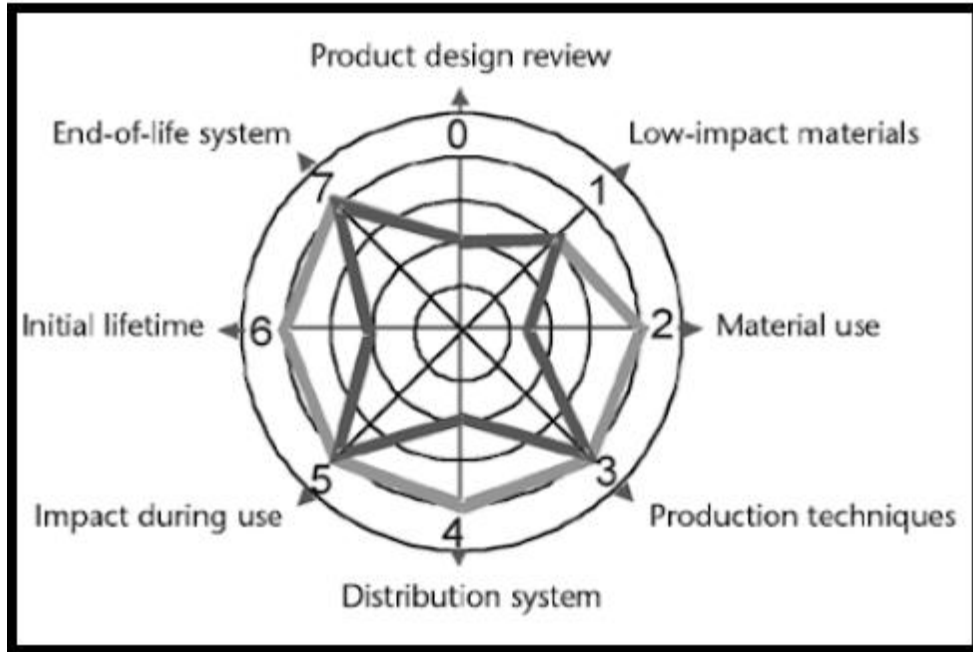


Figure 10: Eco-design Strategy wheel adopted from [33]

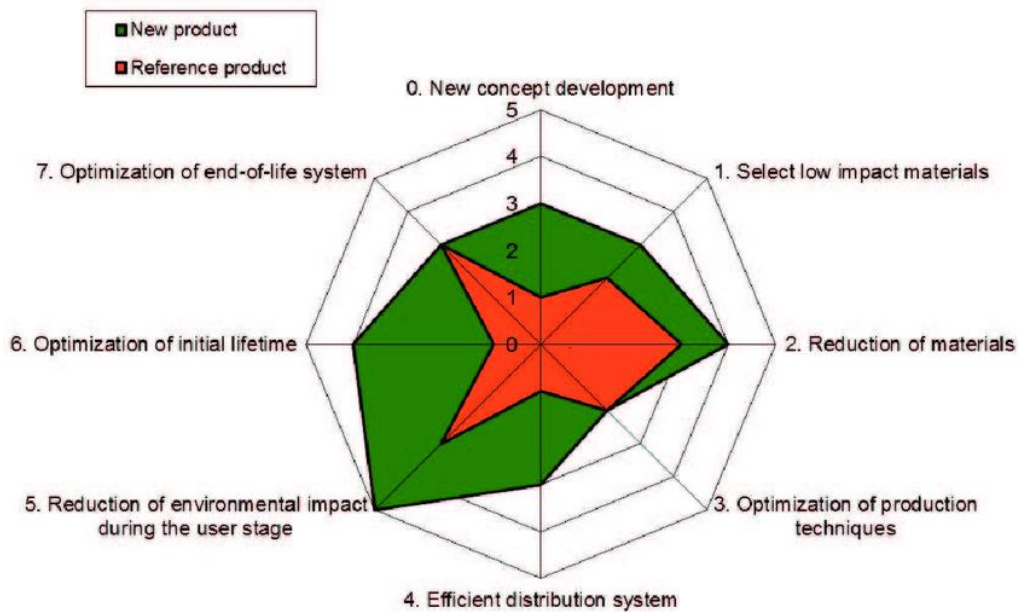


Figure 11: Illustration of the eco-design strategy wheel proposed in (Brezet and Van Hemel, 1997).

Record and Sorting options (best practices):

Finally, all cleaner options suggestions were recorded and summarized in chapter 4. These options were sorted into two main categories. The first options could be implemented directly inside the olive mill facility, such as management options, awareness among workers, good housekeeping, reducing water, and energy consumptions. On the other hand, options need future investigation, such as change retrofit/technology of olive oil extraction, change of waste management techniques, minimize OMW. Those options need a feasibility study, as mentioned in the next section, 3.3.4 [33].

Cleaner production opportunities were listed as best practices for each general option have a list of options that could be implemented regarding mill characteristics.

### **3.3.4 Evaluation and Feasibility Study:**

After options generation, many options for the olive oil extraction process were suggested. The main objective of the evaluation and feasibility study phase is to evaluate the proposed cleaner production opportunities and to select suitable ones to implement for each facility. Furthermore, each olive mill is distinctive; the main effect of cleaner production and waste generation is the used extraction technology [31,33]. Figure 11 shows the evaluation flow chart, which was developed to evaluate the suitable options

for each industry in four criteria, primary evaluation, technical evaluation, economic evaluation, and environmental evaluation.

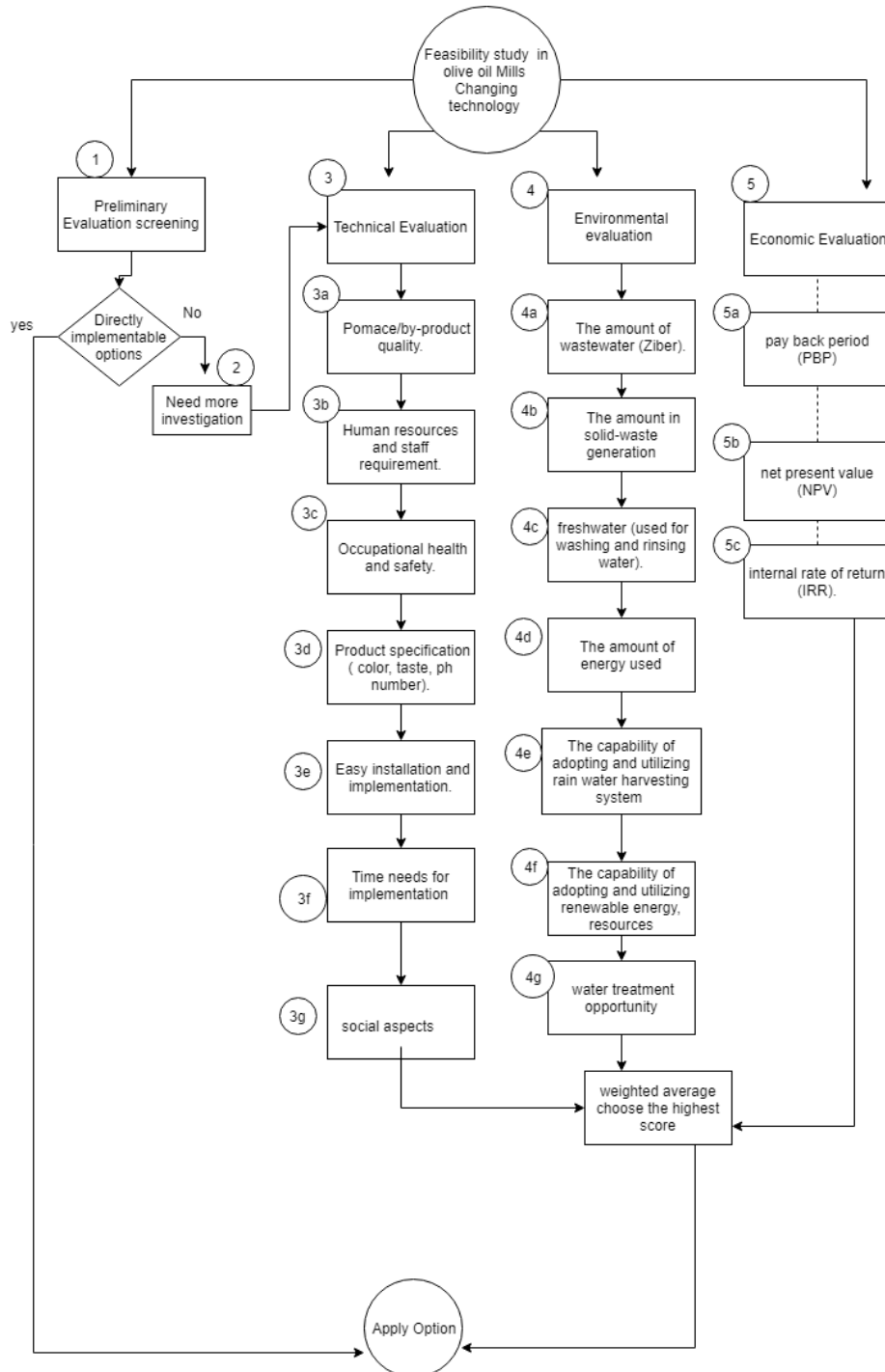


Figure 12: Cleaner production options evaluation flow-chart

The following steps were followed to evaluate the options:

- Preliminary evaluation:

It is the initial and easiest evaluation to make; in this step, it is decided if the option could be directly implemented in the olive mill or a future investigation study is required. [31,33]

- **Technical Evaluation:**

These criteria are concerned with the evaluation of the direct impact on the desirable product, production process, occupational health, and safety issues.

The changes which will follow the implementation should be evaluated through a laboratory test, a simulation study, or trial runs. The technical evaluation gives us a clear picture if there would be needs for staff change, maintenance, training, or change product specification, such as taste or color.

In this research, seven criteria were selected to evaluate the olive oil process.

These criteria were adopted from the literature review, interviews and international standard ISO 14001, as shown in table two [31,33].

**Table 2 Technical Evaluation**

Technical	critierion	Effect
1	Pomace/by-product quality.	Positive impacts
2	Human resources and staff requirement.	Negative Impact
3	Occupational health and safety.	Negative Impact
4	Product specification ( color, taste, ph number).	Positive impacts
5	Easy installation and implementation.	Positive impacts
6	Time needs for implementation	Negative Impact
7	social aspects	Positive impacts

**- Economic Evaluation:**

Cost, specifically the investment cost, is an essential factor in most companies and profit is the main target for any company, including in Palestine. The economic evaluation step aims to assess the cost-effectiveness of cleaner production opportunities after implementing the options. Furthermore, it's a vital element to decide and adopt this option or rejects it.

The cost reduction benefits should be clear to the company; the following questions might help to understand the economic evaluation; in other words; is the option reducing the environmental cost? Is the option reducing waste treatment cost? or, is the option reducing the consumption of resources?

In this phase, the cost of investing in new options and the changes that may happen was weighted against the saving may result.

The cost divided into capital cost and operating cost.

1) payback period (PBP)

$$\text{payback period} = \frac{\text{capital investment}}{\text{Annual savings}} \quad (1)$$

$$p = \frac{PYFR+BA}{CIYER} \quad (2)$$

where,

P= payback period, PYFR = Number of Years immediately preceding year of Final Recovery BA = Balance Amount to be recovered, CIYFR = Cash inflow — Year of the Final Recovery

2) Net Present Value =

$NPV =$

*Today's value of the expected cash flows – Today's value of invested cash* (3)

$$NPV = \sum_{t=1}^T \frac{\text{capital investment } t}{(1+i)^t} \quad (4)$$

Where,

T= cash flow period.

i= Interest rate assumption.

3) Internal Rate of return:

$$IRR = \sum_{t=1}^t \frac{C_t}{(1+r)^t} - C_0 \quad (5)$$

Where:

$C_t$ = Net Cash Inflow During the Period  $t$ .

$R$ = Discount Rate.

$t$ = Number of Time Periods.

$C_0$ =Total Initial Investment Cost.

Sample of calculation presented in chapter 4.

- **Environmental Evaluation:**

The main objective of the environmental evaluation is to assess the environmental effects of the proposed option; positive or negative impact during the lifecycle of the product after implementing the proposed options.

In the olive oil industry, the environmental effects obviously could be a reduction in OMW, reduction in water and energy consumption, the quality of by-products such as pomace, the toxicity of Ziber and concentration and the waste disposal methods.

These criteria adopted from the literature review, interviews and international standard ISO 14001. As shown in Table [33,31].

**Table 3 Environmental Evaluation**

Enviromental	Criterion	Impact
1	The amount of wastewater (Ziber).	Negative Impact
2	The amount in solid-waste generation	Negative Impact
3	freshwater (used for washing and rinsing water).	Negative Impact
4	The amount of energy used	Negative Impact
5	The capability of adopting and utilizing rain water harvesting system	Positive impacts
6	The capability of adopting and utilizing renewable energy, resources	Positive impacts
7	water treatment opportunity	Positive impacts

### 3.3.5 Weighted Sum Method [33]

In this section, the weighted sum method was adopted to evaluate the alternatives in environmental, technical, and economic parameters. The weighted sum model is widely used in multi-objective optimization problems. Simply this model works as making comparisons between different objectives and gives weights for each objective to create a single score for each alternative to be a quantitative comparison the Weighted Sum Model Scoring Function used as below 6 and 7:

$$A_i^{wsm-score} = \sum_{j=1}^n w_j a_{ij} \quad (6)$$

$$A_*^{wsm-score} = \text{Max}_i \sum_{j=1}^n w_j a_{ij} \quad (7)$$

Where:

WSM: weighted some score.

n= number of criteria.

$A_i$ : the maximum score for alternative i.

$w_j$  : the weight for the criterion  $c_j$ ,

$a_{ij}$  : the score of alternative i. for criterion j.

In this model, the maximum score is the optimum alternative to select in case positive results were shown; on the other hand, the optimum alternative in negative results is the lowest score. [34].

-Weighted sum method to evaluate alternative establish a scoring tool:

A ranking method was developed to evaluate each creation in the feasibility study, a range from +3 to -3 was taken, as the following table:

**Table 4 Evaluation of alternative option scouring method [31]**

score	Description
3	Highest positive effect
2	Medium positive Effect
1	lowest positive effect
0	No effect
-1	lowest negative effect
-2	Medium negative Effect
-3	highest negative effect

is the highest score positive effect after implementing the option, also -3 is the highest negative impact after implanting the option.

- Give the weight for each criterion in the feasibility study:

Each criterion in the feasibility study was given weight through the conducted questioner in chapter 4. The data was analysed to illustrate weighting methods.

### **3.3.6 Implementation and Continuous Improvement**

The primary purpose in the last phase in assessment is to ensure the implementation of selected options in a planned manner and specific time frame, in addition to the reduction in consumption of resources and reduction in generated waste is monitored continuously.

Three steps were taken to achieve implantation options in a planned manner:

#### **3.3.6.1 Prioritization of Cleaner Production Option**

After conducting the feasibility analysis, several options will emerge with different levels of technical feasibility, economic viability, and environmental performance. It is not preferable to adopt all options at the same time; thus, a framework was developed to evaluate the prioritization of options. A weighted-sum method was considered as the tool.

First, for each parameter in the feasibility assessment (technical feasibility, economic viability, environmental performance), weights were assigned to each of the three aspects. These weights were decided through a brainstorming session and with interested parties during conducted interviews were data analyzed in chapter four.

Second, simple indicators of "scores" were developed to assess the relative performance of each option. Each option is then evaluated on a subjective basis and scores assigned to each of the three aspects. The Scores were

given a range from 0 to 3 table 3 shows how the score assigned from feasibility assessment; It should be noted that the intention is not to prioritize each option individually but to group them into categories such as top priority, medium priority, and low priority. Table 4 shows how categories developed and ranked. The results would then be the basis for preparing the implementation plan.

$$F = E + T + C$$

Where,

F= The Total option score from Environmental Feasibility, technical feasibility, and economic feasibility.

E= Environmental feasibility score.

T= Technical feasibility score.

C= Economic feasibility score.

**Table 5 how to assign a rank for prioritization**

F = option score from feasibility assessment	Prioritization score
$F \leq 0$	0
$0 \leq F \leq 15$	1
$15 \leq F \leq 30$	2
$30 \leq F$	3

**Table 6 Priority categories**

Level of the priority	score range
Top	3
Medium	2
Low	1 or 0

**3.3.6.2 Developing a Cleaner Production Plan:**

Finally, after assigning the priorities of options and direct option to implement in the olive mill or factory, a clear working plan should be developed, project management concepts used in this phase with focusing on the start and finish time for each task, and responsibilities should be assigned between project team in the plant, and expected cost.

Regarding monitoring and evaluation for continuous improvement, which could be through internal audit program, consumption report from production reports, consumption for resources from monthly bills, reduction of cost, profit, reduction of waste generated, etc.

## **Chapter 4**

### **Results and analysis**

#### **Cleaner Production Best Practices in Olive Oil Industry**

##### **4.1 Overview:**

After conducting interviews with interested parties through the questioners; and review the necessary literature data, cleaner production implementation was taken a place through cleaner production methodology adapted from UNFP, cleaner production options and best practices for the Olive oil industry were developed customized to the Palestinian industry.

##### **- Pollution Potential:**

Olive oil production tends to create pollution problems and to generate wastes to varying degrees. It is of particular importance that those processes produce highly toxic or ingredients that are difficult to be destroyed or stabilized and disposed of in an environmentally sound manner.

Section 4.2.1 illustrates that all types of wastes resulted from olive oil mill extraction processes.

## **4.2 Cleaner production development for Olive Oil Industry**

### **4.2.1 Pre-assessment phase evaluation of the olive oil process**

The pre-assessment was conducted, by walk-through different types of olive oil mills, three production oil extraction technology used in Palestine.

- Traditional pressing mill technology.
- Three-phase decanter extraction.
- Two-phase decanter extraction.

A process flow chart was developed through literature review and walkthrough mills during interviews. The flow chart illustrates the input and output of the process through different techniques. Figure 12 shows the input material during production and the waste generated from each process, including wastewater and solid waste generation as a block diagram. The process flow chart describes the process from harvesting to filing olives oil in the storage tank.

Olive Oil Production Process (process flow chart)

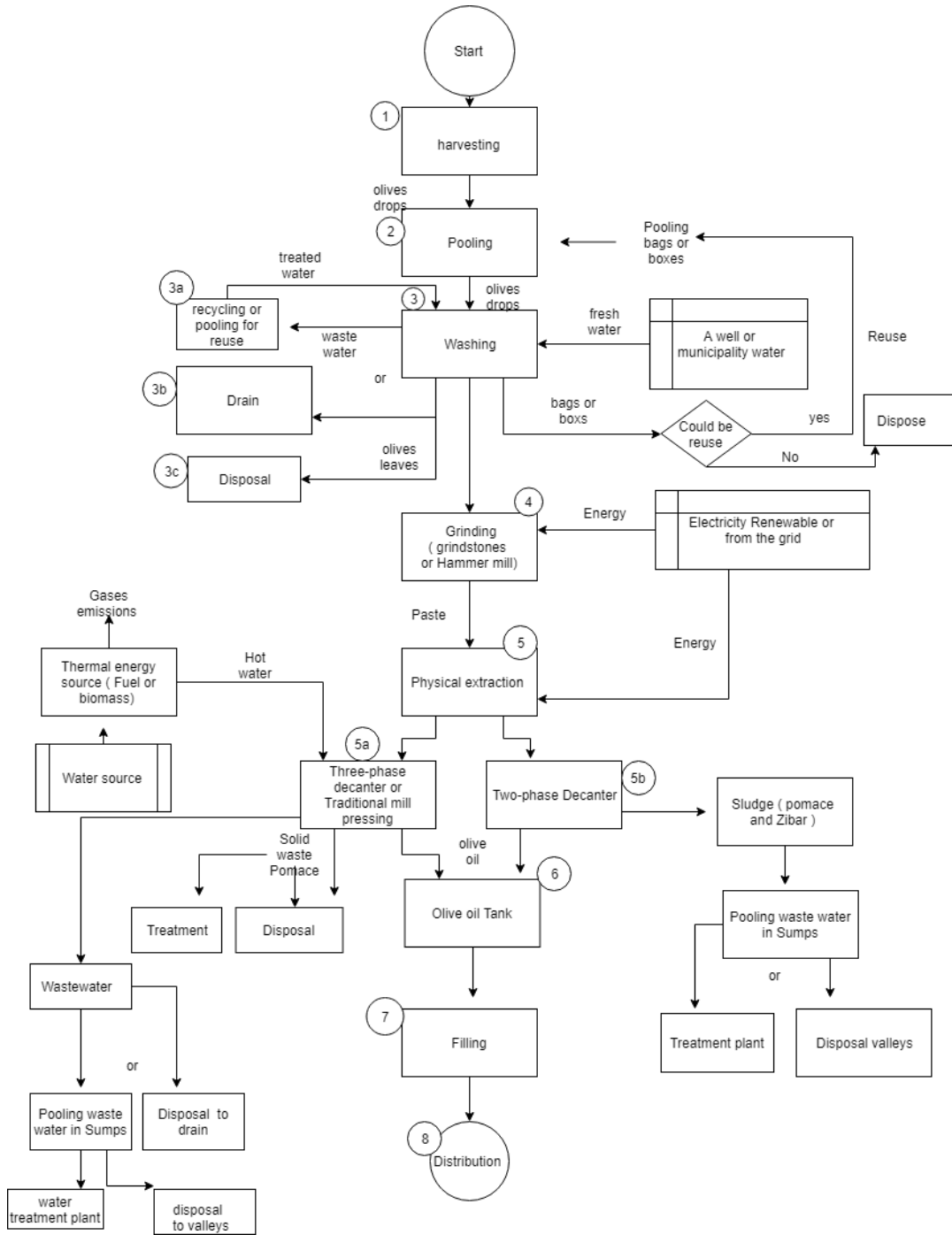
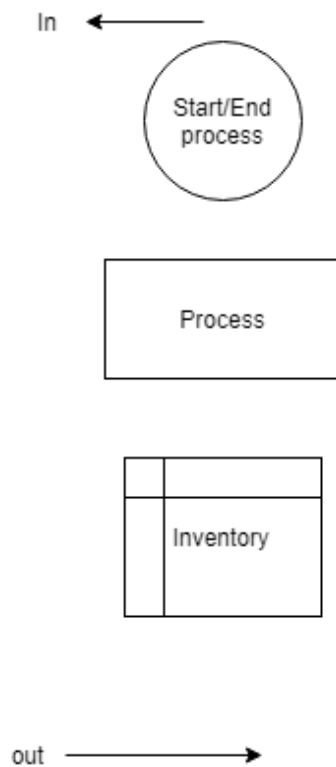


Figure 13: Olive Oil Production Process (process flow chart)

**Key for the following chart:**

**Figure 13 shows the key for the flow chart used.**



**Figure 14:** key for Process flow chart

## - **Description of process and process environment**

### 1) Harvesting Olive Seeds:

harvesting is the first step on the olive oil production, by the harvesting season from October through December using traditional methods of harvesting the farmers collect the yield to move it to the next step which is pooling.

2) Pooling: olives drupes pooling in a plastic or fibers bag for 50 kg or plastic boxes. Plastic/fiber bags have a significant impact on the oil quality

and waste generated due to pressures on olives drupes, and a longtime of storage the bags before sending it to the mill will affect negatively the quality of oil and waste generated. Regarding the boxes, it is much better and keep the olive drupe fresh and avoid pressing the drops during storage the mill has an option to reuse the bags or boxes or disposal as solid waste but our recommendation to use open boxes for olives drops pooling that will reduce the water consumption for washing and energy use in processing and the olive mill waste generated . [34]

3) Washing: after olives drop received to the mill; olives drupes are washing by adding water using different techniques such as water spray or water pool for reuse the water instead of disposal, the main effect of this process is to remove physical impurities such as leaves, pieces of wood, as well as any pesticides. Wastewater generated from this process; some of the mills reuse it using water treatment channels, and others dispose of the wastewater to drain, leaves and other solid waste dispose outside the mill; a control measures should be used here to increase the efficiency of washing and reduce the consumption of freshwater and reduce wastewater generated and it could be reuse in closed-loop system.

4) Grinding: the olives drupes after the washing process, moved to grind and mixed into a paste through the crushing process. Two methods used in Palestine:

a) Traditional pressing mill: used grindstones for milling to produce the paste.

Here losses in paste could exist and less electricity used.

b) Hammermill: using extra-hard tungsten steel heads instead of grindstones as continues to mill the seeds, the output the higher quality of paste and need more electricity consumption.

5) Physical Extraction Process:

Physical extraction is a critical process in this industry; the kind of technology used in this process will control the quantity and quality of oil and waste generated.

Three-technique used in Palestine to extracting the oil from the paste.

- Traditional pressing

A hydraulic piston pressing the paste through fiber disk a mechanical force pushes the paste through fiber desk layers squeeze out to produce oil, solid waste pomace, and wastewater (Zibar), a few numbers of the mill operated in Palestine using this technology it considered old technology.

- Three-phase decanter:

Centrifugation force produced from the decanter to separates the paste, three output produced which are oil, wastewater (Zibar) and Solid waste (Pomace). Hot water added to decanter with 25-30 C; that produces more

wastewater and reduces the yield of olive oil due to losses in sludge channel and wastewater channel. This technology is widely used in Palestine.

- Two-phase decanter

The same technique of decanter centrifugation but without adding hot water to decanter, less wastewater and solid waste produced, high quality of olive oil, its environment-friendly the output (oil, and sludge) also less energy is used. In the west bank, one mill in Aroura Village and another one in the Palestinian ministry of agriculture for laboratory used, in Europe countries two-phase decanter is widely used.

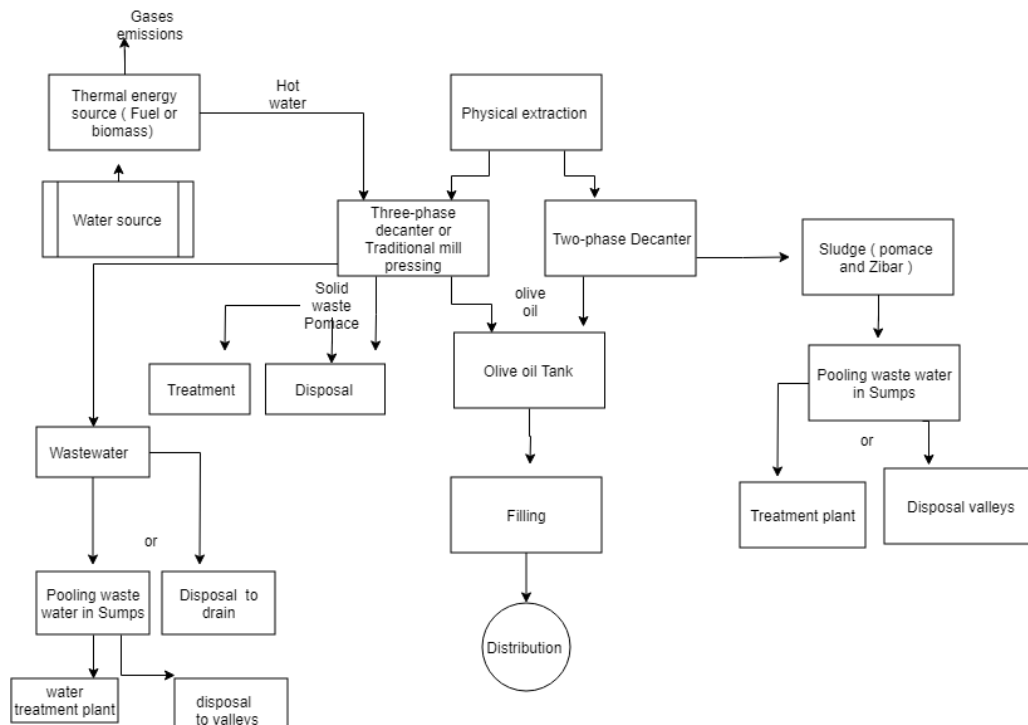
6) Filling and distribution:

The oil storage inside a stainless-steel container or plastic container for long time storage. A glass filling production line could be used here and metallic cans. The olive oil in the local market distributed in a plastic container, metallic cans, and glasses bottle. Regarding distribution to outside Palestine, they use glasses and metallic cans as a packaging material due to export regulation.

- Disposal of waste in Palestine:

After walkthrough and interviews with mill owners solid-waste from the olive mill, the improper desiccation of the olive pomace causes a pollution problem. The solid-waste sludge contains a wastewater Zibar and olive oil

that is transferred to farming lands and groundwater. Finally, TPOMW( Two Phase Olive Mill Waste ) is more complex in disposal due to the high concentration of toxic material Even though the amount of wastewater is less than the three-phases olive mill, but the chemical components here are complex and cause a higher pollution impact if disposed of improperly. Figure 12 shows the disposal methods in Palestine for the waste from olive mills. [35]



**Figure 15:** Current disposal methods in Palestine [36]

*Olive Mill Waste:*

## 1) Two-Phase Olive Mill Waste (TPOMW):

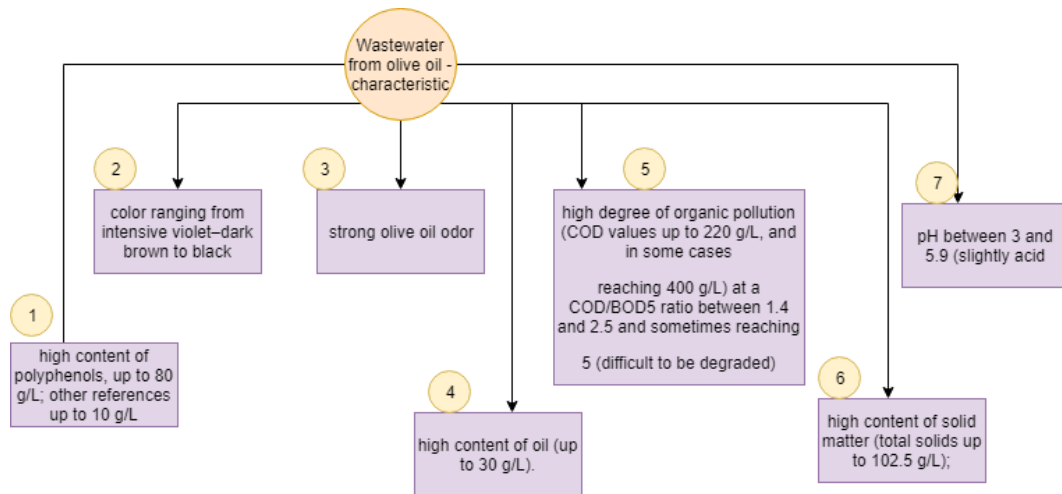
The concept of Two-phase mill and the cause of the name due to; two outputs produced after the extraction process, which is oil as end produce and wet-sludge as waste. The Pomace and Zibar generate to gather with high concentration but less quantity than three-phase decanter due to no water used during production inside the decanter. The waste generated in Two-phase called TPOMW. The main characteristic of it is highly concentrated on polluted material; so the wet sludge needs advanced technology to minimize the toxic component from it and treatment [36].

## 2) Three-Phase olive Mills Waste (OMW)

The concept of Thee-Phase extraction process is to produce three main outputs after the extraction process, which are the oil, the Solid waste Pomace and Wastewater Zibar each one separated from each other.

As mentioned before two sources of wastewater exist in olive oil production, rinsing water and it is easy to manage and safe end of good housekeeping and water reduction techniques considered as control measures to minimize this kind of wastewater. on the other hand, Zibar considered toxic material and harmful for the environment; due to high concentration of acidity and phenol. In the three-phase decanter the quantity of wastewater considered high; due to using hot water in the decanter [37].

Figure 17 shows the characteristics of the wastewaters from olive oil mills.



**Figure 16:** wastewater characteristic [37].

The solid waste generated from the three-phase extraction process is less toxic and has less direct negative environmental impact issues. Some bad practices noticed in Palestine such as pooling the Pomace in a farming land to dry this practice harmful to the environment due to high probability to transfer the Zibar to the ground and polluted the groundwater also polluted the soil with high acidity component and phenol. After sludge dry the farmers collect the Pomace and use it as input for other industries such as for the Soap industry usually do some processing to extract the olive oil lost from paste, also it could be used as biomass energy [35].

- Table 7 shows Input-output analysis for the olive oil process:

**Table 7: -Input-output analysis**

Process	Inputs for process	Process	Outputs of process
Harvesting olive seeds	Human resource	start harvesting from trees in manual method our automation.	Olives drops
pooling	Olives drops	Collecting Olives drops in containers	Olives drops in plastic bags or plastic box
washing	Olives drops and Water	Olives drops wash to clean olive drope from Pesticide, dust, soil, remove Olive leaves and other.	Olives drops, Wastewater
Grinding	Olives drops, electricity	Milling olive oil seeds	Paste
Physical extraction	Paste , Water , Electricity	Paste will be squeezed and processed through physical technology to produce oil	Olive Oil ,Solid waste (pomace) , wastewater ( Zibar)
Filling	Olive	The oil will be saved in stainless steel container or plastic tank some time Nitrogen will be added, filling in glass, or filling in can's, or small plastic tank	Packed olive oil
Inventory	Packed olive oil	Packed olive oil in a room with 25 C temperature avoid sun	Finished product

Ecomap of the Site:

Ecomap used as a second phase for pre-assessment of the olive oil mill processing, walkthrough three types of olive mills operating in the West Bank was made, also after walkthrough the mills production line note for each process was summarized in the layout of each mill as ecomap to illustrate the wasted water in the process, solid waste generation, and energy consumption . The following three figures show the results of the walkthrough in different production mills three-phase decanter, two-phase

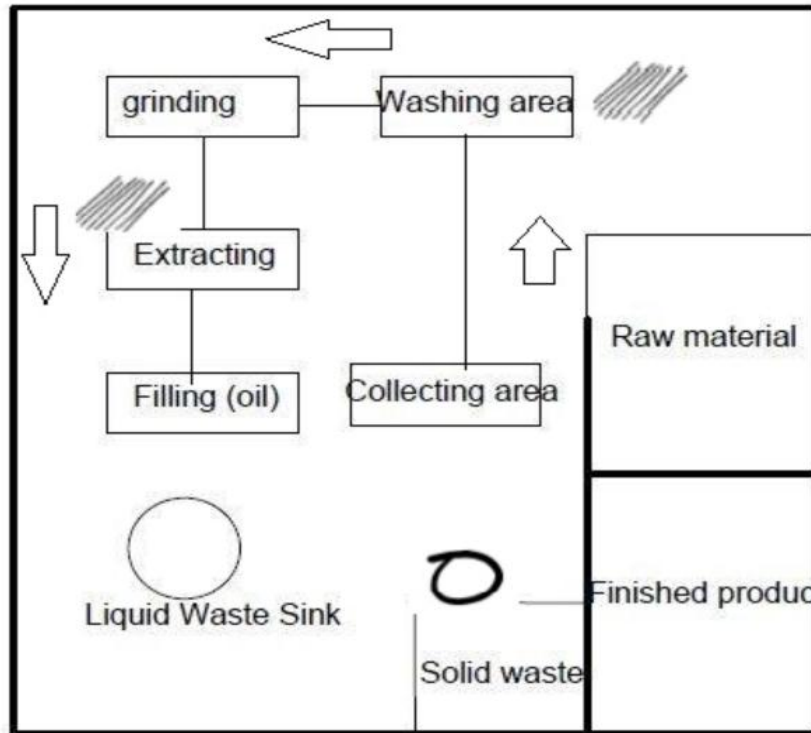
decanter, and traditional mill. , whereas each figure shows different ecomap they are (Wastewater Ecomap, Energy Ecomap, Solid Waste Ecomap) [37].

Key Used for Eco Map:

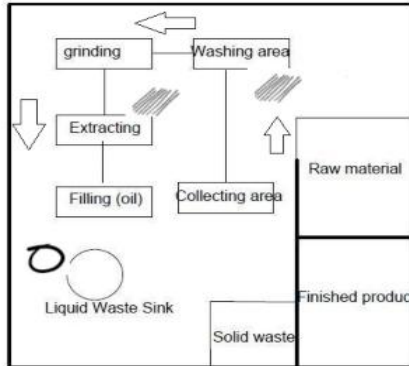


**Figure 17:** Eco Map key [38]

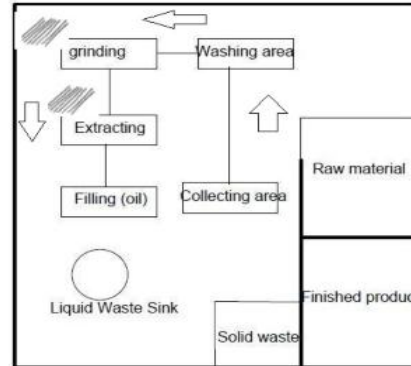
Traditional Mill Solid Waste Eco map



Traditional Mill Water and Wastewater EcoMap



Traditional Mill Energy EcoMap



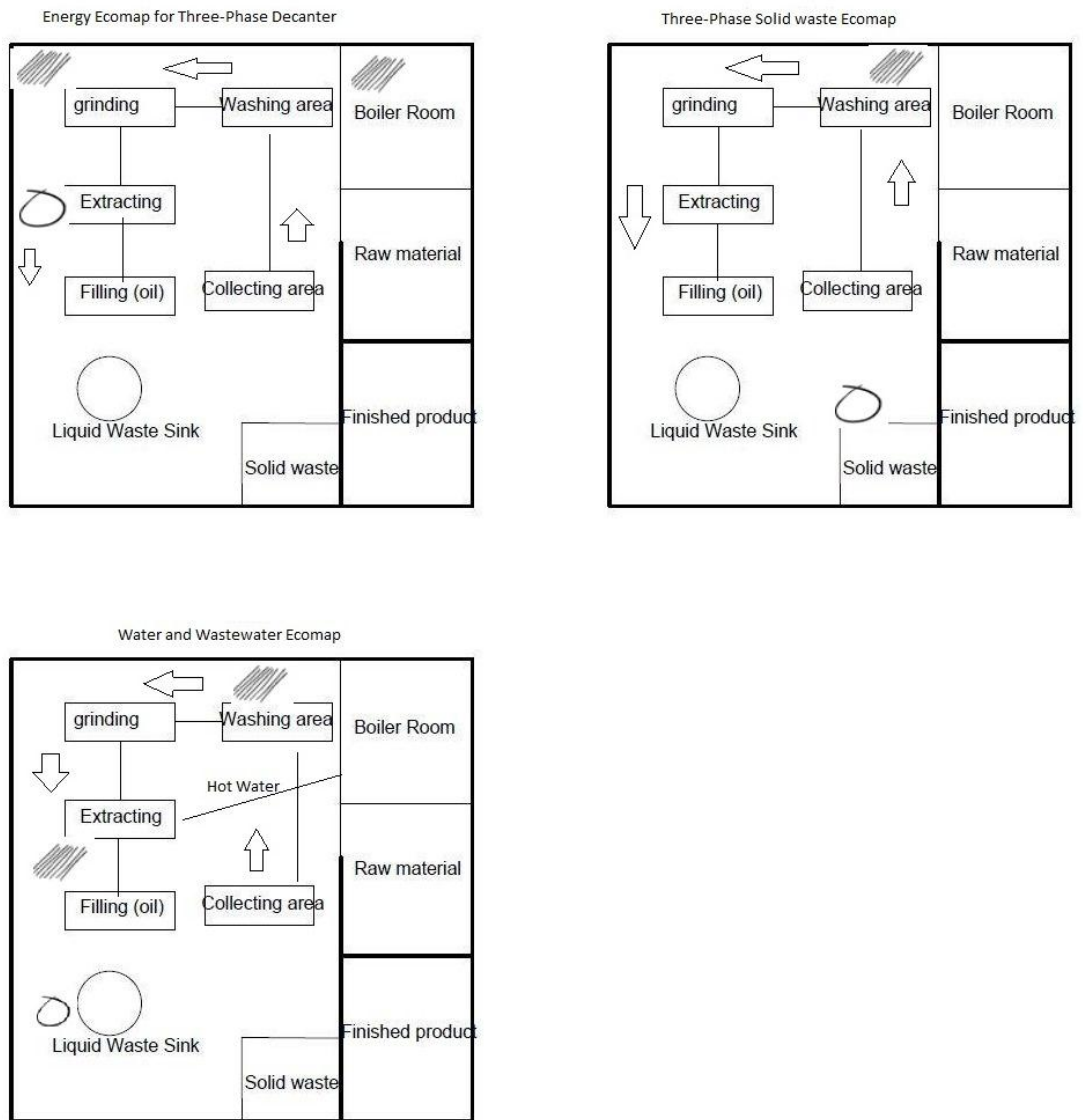
  
Requires  
immediate  
attention

  
Requires attention

  
Requires Monitoring

Figure 18: Traditional pressing Mill Eco-map

The results from ecomap for traditional mill extraction process; monitoring shall be existing in the washing raw material process on freshwater consumption, and the system used for washing and reuse water. Furthermore, immediate attention shall be existing in both; the solid waste and wastewater Zibar generated, regarding energy consumption a monitoring system should exist for bills and consumptions during the season.

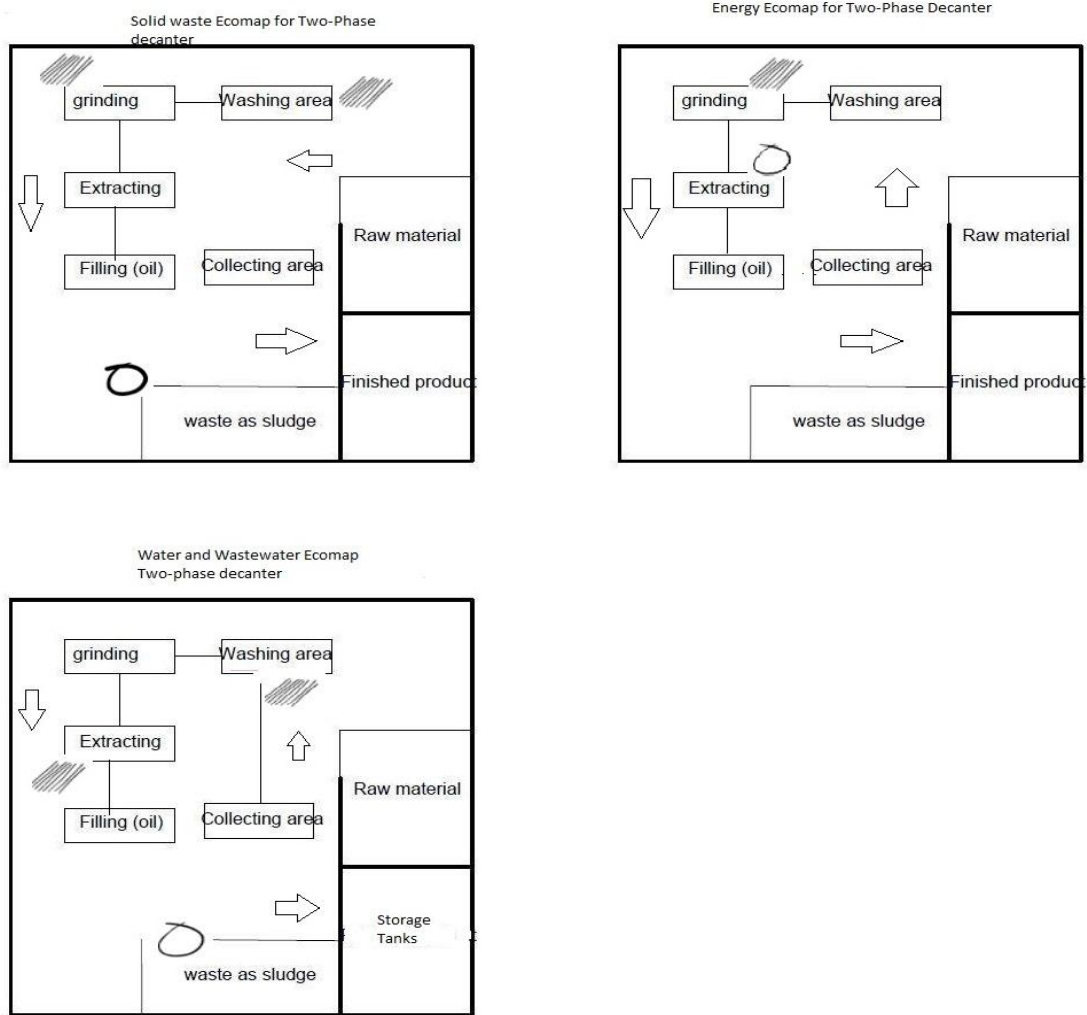


made by www.MakiePhotoGallery.net

Figure 19: Three-Phase Decanter Mill Eco Map



The results from the ecomap for the three-phase decanter mill extraction process; monitoring shall be in the consumption of freshwater in the washing process and in the water consumed during extraction for the decanter monitoring shall be in both temperatures of water and quantity. Furthermore, immediate attention shall be made in both solid waste and wastewater Zibar generated due to there is a large quantity of wastewater should be monitored and be controlled, regarding energy consumption a monitoring system should exist for bills and consumptions.



made by www.MakePhotoGallery.net

**Figure 20: Two-Phase Decanter Eco Map**



The results from the ecomap for the two-phase decanter mill extraction process; monitoring shall be in the washing process and quantity of water used. Furthermore, immediate attention shall be made in wet-sludge ( zibar + pomace ) it is less quantity than three-phase but high concertation

of Zibar and especially phenol the waste should be monitored and be controlled and dispose of in an eco-friendly way, regarding energy consumption a monitoring system should exist for bills and consumptions.

#### **4.2.2 Assessment (quantitative data)**

The assessment phase aims to identify the quality and quantity of raw materials, energy, and water consumed during production, and the wastewater, solid-waste or by-product generated in the olive mill extraction process.

##### *Material Balance.*

Input-Output Evaluation preliminary material and energy balance was made, after conducting walkthrough production areas and sites diagnosis of olives oil mills working in Palestine, data collected from interviews and observation, the following results were obtained for seven olive oil mill, four three-phase decanters, one two-phase decanter, and two traditional pressing mills.

To develop Material Balance for olive mills the following indicator was adopted from literature and research:

- 1) Regarding water consumption, the cost of water during season was calculated by dividing the cost on the direct cost of 1 cubic meter in Palestine ,the price between cities in West Bank different from place to

another, the average price of 1 cubic meter is 5.7 ILS as published and announced by water sector regulatory council [38].

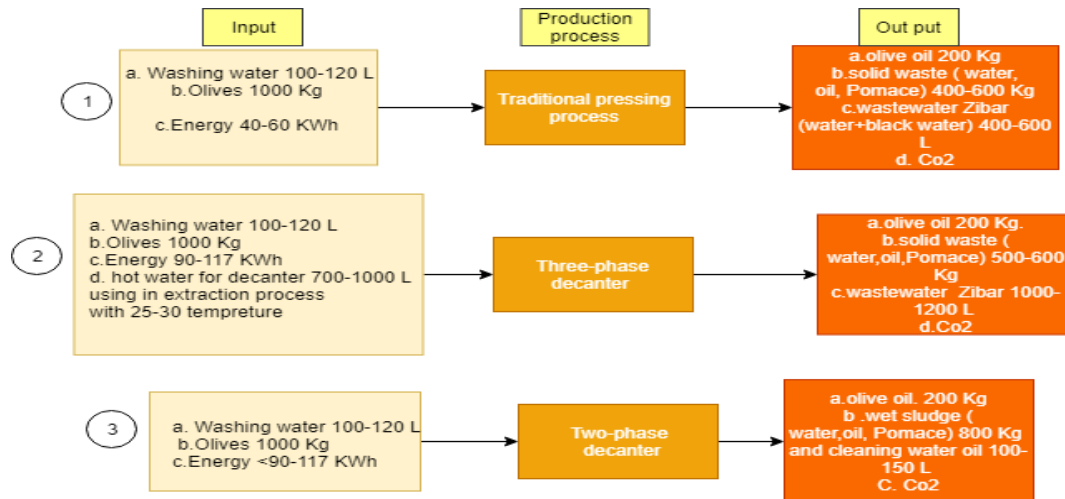
2) Electricity consumption was calculated, by dividing the cost of electricity consumption during the season on the direct price of 1 KWH in Palestine the cost for electricity consumption in West Bank is 0.6367 as published and announced by Northern Electricity Distribution Company [39].

3) Regarding Solid waste generated, the cost for one ton of pomace is 50 ILS; by dividing income from selling pomace to farmers, on the price for one ton of pomace, the estimation of solid waste was calculated. [40].

4) The standard consumption for olive oil production freshwater and electricity consumed during the production of 1 Ton of olives drops, in three different production technology was considered, also solid waste and wastewater generated was considered. Used as a benchmark to develop consumption acceptable and normal rate to make comparisons between the actual rate of different production technology in Palestine, the standard consumption rate and waste generated rate was taken from two main sources of previous research.

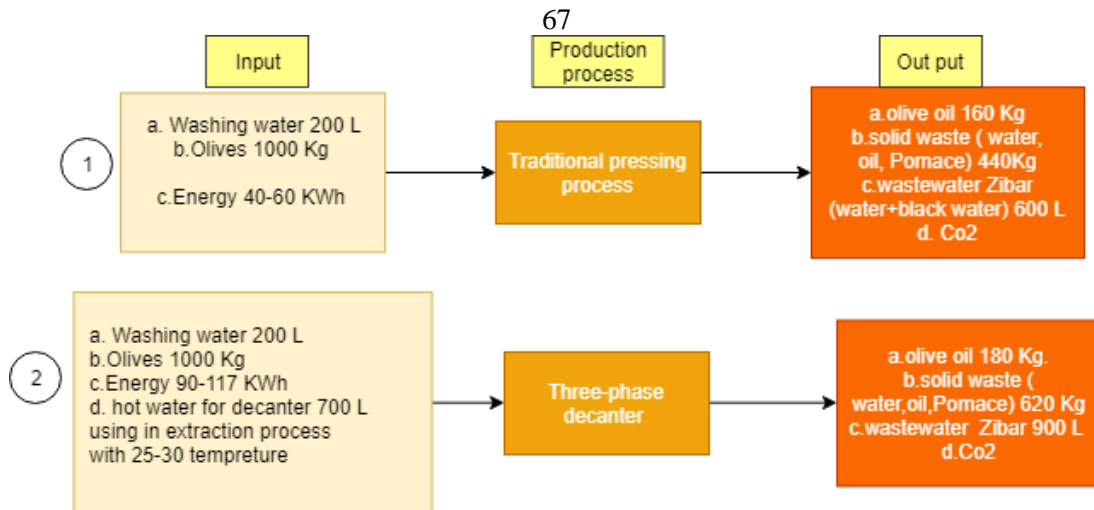
a) The first source from a study was made in the Meditation area by Centre for Cleaner Production (RAC/CP), the following material balance describe the results of olive oil extraction with three different extraction

techniques. one ton of olives drops was considered as reference, figure 18 shows the Material balance [31].



**Figure 21:** Material Balance for extraction technology in Mediterranean area [36]

b) The second source of consumption rate and olive oil mill waste generated was from a study made in Palestine, the study illustrates the consumption rate and the Olive mill Waste generated from two different olive mill production technology, also one Ton of olives drops was the reference unit, furthermore the two-phase technology in Palestine is new, whereas one olive mill operated in Aroua Ramallah, absence of data for consumption rate of raw material and olive mill waste generated ratio was noticed in the Ministry of Agriculture. The figure shows the material balance result from the study [35].



**Figure 22:** Material Balance for extraction technology in Palestine [35]

Table 8 describes data collected from consumption bills for the last olive oil season 2018 and interview with olive mill Owners, a general idea and overview were observed regarding input and output from the production process. The data collected reflect the olive oil season from October to the end of December 2018

**Table 8: Olive oil Extraction Material Balance**

Season 2018																
Mill Type	Mill Location	Olives drupes input /Ton	out put Olive Oil /Ton	Water cost/ ILS	Water consumption/ L Actual	water consumption /L standard	Electricity cost /ILS	Electricity consumption KWH Actual	Electricity consumption KWH standard	income from Solid waste ILS	Solid waste generated Actual /Kg	Solid waste generated Standard /kg	Fuel type/cost	wastewater disposal cost	Wastewater generated standard/L	Wet-sludge/L
Three-Phase decanter	Kufor Qadom - Nablus	1100	275	11,000	1,929,824.56	990,000.00	35,000	54,970.94	122,400 to 159,120	8,000	160,000.00	682,000.00	biomass	30,000	990,000.00	not exist
	Salfet	360	120	2,800	491,228.07	324,000.00	14,000	21,988.38	32,400 to 42,120	5,000	100,000.00	223,200.00	biomass	10,000	324,000.00	not exist
	Kufor Sour- Tulkrem	24	6	450	78,947.37	21,600.00	2,500	3,926.50	2,160 to 2808	1,000	20,000.00	14,880.00	biomass	6,000	21,600.00	not exist
	Alar-Tulkarm	60	15	400	70,175.44	54,000.00	10,000	15,705.98	5,400 to 7,020	2,000	40,000.00	37,200.00	13,000 diesel	7,000	54,000.00	not exist
Traditional pressing mill	Canaan	200	50	850	149,122.81	120,000.00	7,000	10,994.19	8,000 to 12,000	1,500	30,000.00	88,000.00	10,000 diesel	9,000	120,000.00	not exist
	Al Junaide Nablus	35	6	100	17,543.86	7,000.00	800	1,256.48	1,400 to 2,100	N/A	N/a	15,400.00	biomass	N/A	21,000.00	not exist
Two-phase decanter	Aroua -Ramallah	50	13	150	26,315.79	10,000.00	1,500	2,355.90	4,500 to 5,850	Not Exiest	Not Exiest	Not Exiest	Not exist	Not exist	not exist	40,000.00

### Analysis and Conclusions from Table 8:

- A. The olive yields from three processes are almost in the same range between 200-350 kg from 1000 kg olive of olives drupe it means between 25% to 30% oil produced from processing 1000kg of olives drupes.
- B. Water consumption increases in the three-phase decanter; due to hot water used in the decanter, and that produced a higher quantity of wastewater.
- C. Electricity in three production technology consumption inside mills during the season within the acceptable level and international standard for consumption rates.
- D. In comparison between the actual consumption of freshwater against the international standard of water consumption, it's clear there is a problem in local mills, in managing the consumption of freshwater, it means poor practices and management for resources or old technology used without maintenance and monitoring.
- E. The Zibar generated from the three-phase decanter is higher than other techniques due to added water to decanter during processing, despite the wastewater concentration produced is less than the two-phase process.
- F. The water in solid-waste from the three-phase decanter is more than the traditional method and two-phase that will affect the time needed to dry to collect the olive Pomace and more pollution from wastewater in sludge.

- G. Electricity consumption in two-phase Decanter is less than in three-phase Decanter.
- H. Two-phase decanter generates the minimum waste ratio but with a high concentration of toxic material to the environment.
- I. The disposal method for the Zibar in Palestine by pooling it inside sumps, and transfer it through external tanks and disposed of it in valleys or to water treatment plants.
- J. The Solid waste Pomace sold to soap factory or pressed in block to reuse it as energy source biomass and it considers as a by-product.

Environmental Impacts Cleaner Production Opportunities (establishing a focus area)

Wastewater, sludge (solid-waste-Pomace) and wet-sludge are the wastes produced by different extraction processes from olive oil mills, the poor release or dumping of vegetating water and allow to the sludge dry in free lands can create a wide range of environmental damages causing severe human health effects.

These effects may vary from the olive oil extraction process to another, and it depends on the pathway of wastewater and sludge disposal at the environment knowing that it also depends on the holding time for the wastewater and sludge inside the mill.

The disposal method in Palestine of the wastewater into valley "wadies" as end-of-pipe without treatment after disposal through the valleys or collection of the waste in sumps to disposed of by third parties outside mill also to valleys or to the water treatment plant. The problem of disposing it near mill or in valleys is the wastewater leaks out with groundwater and the untreated flowing municipal wastewater. This leads to a high quantity of wastewater flow continuing. Organically, polluted wastewater will affect the soil and water supply sources. It was evident that the improper disposal of olive mill wastewater Zibar is harmful to the environment and contributes to biological pollution in a high amount of pollution in water resources and farming lands. An example of biological pollution is the Zeimar valley lying between Nablus City and Tulkarem had polluted from olive mill wastewater with multiple wastewaters where the flow of water goes to Alexander River [35].

This Zibar is dangerous because of the high concentration of phytotoxic and antibacterial phenolic substances and organic load.

In conclusion, the two significant sources of wastes in the olive oil mills extraction process come from wastewater olive mill (zibar) and solid waste Pomace. Thus, the cleaner production analysis will focus on the opportunities existing in the methods of reducing and minimizing the wastes resulted from the process such as changing technology of extraction, water treatment ideas and minimizing the wastewater concentration in

addition to good housekeeping activity to reduce and minimize the harmful of this by-product to environments.

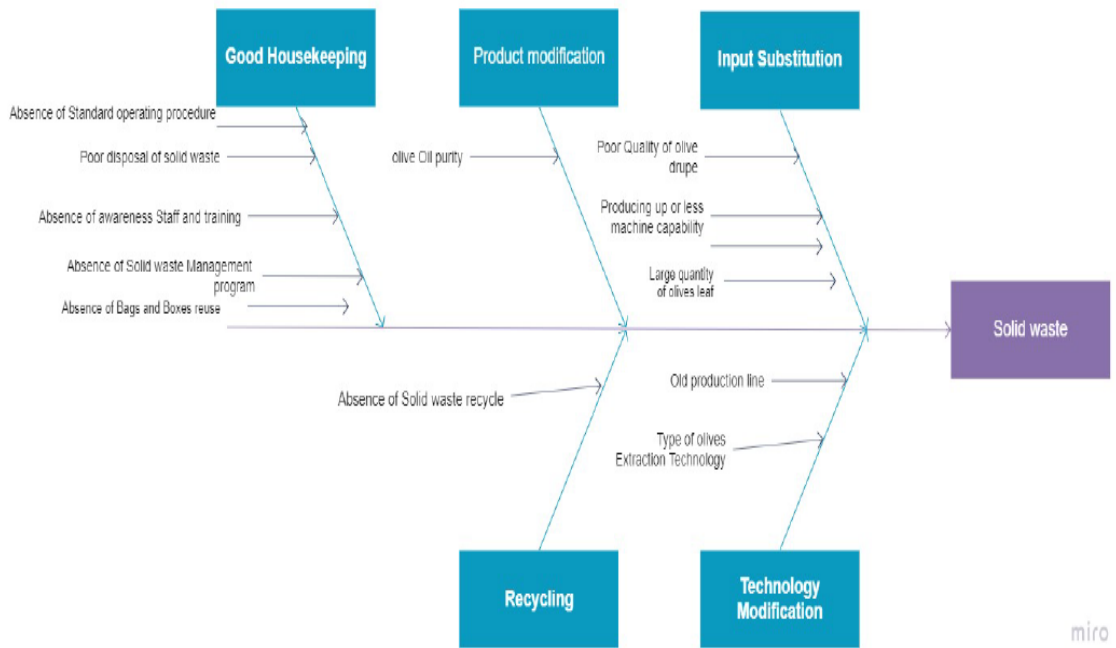
### **4.2.3 Identifying Cleaner Production Options for olive oil industries.**

The Cleaner Production assessment phase starts with making a “diagnosis” of the process to identify shortcomings and their causes, as well as to find options for how to improve it.

Fishbone diagram was used to identify the causes of olive mill waste in three different extraction processes the following result was found:

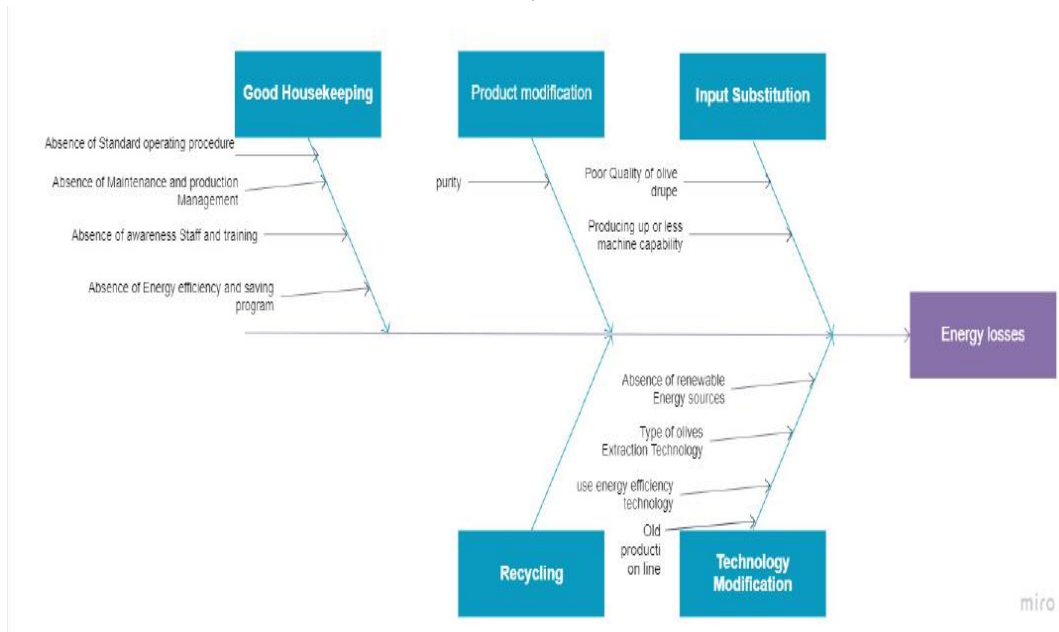
#### **4.2.3.1 Cause Diagnosis:**

- Solid waste generation causes as shown in figure 22.



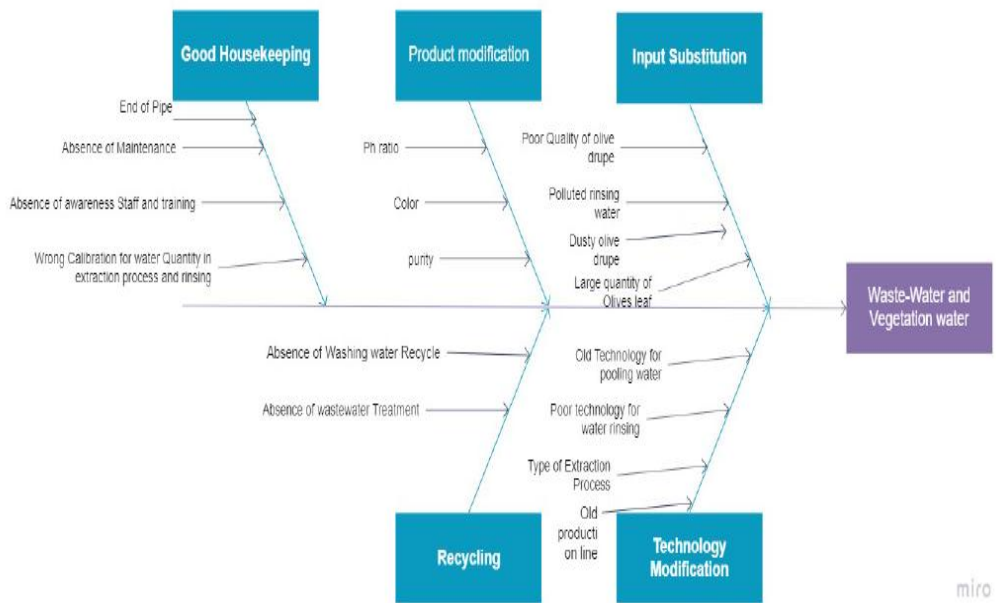
**Figure 23:** Solid waste causes

- Energy losses causes as shown in Figure 23:



**Figure 24:** Energy losses causes

- Waste-water generated causes as shown in Figure 24:



**Figure 25:** waste-water causes

- Matching the causes diagnosed in Fishbone Diagram to generated Cleaner Production Options and best practices as a Data analysis tool.

**Table 9 Matching causes to good housekeeping option**

categories	primary cause	problem description	Cleaner production option and control measures
Good housekeeping	Absence of standard operation procedures	Work without control and monitoring system and documentation system.	Develop standard operation procedures, set objective and plans, adopt ISO 14001 and GMP
	Absence of maintenance program and production plans	Malfunction of production line, leakage of water, increasing the quantity of OMW	Develop a seasonal maintenance plan and proactive maintenance, Adopt ISO 14001 or GMP.
	Absence of awareness and training	Poor awareness between employees regarding water and energy consumption reduction, and best practices for end of pipe	Develop training programs, adopt ISO 14001 or GMP.
	Absence of energy efficiency and saving program	Absence of Energy saving	Develop an energy saving program
	Poor disposal of solid waste	Increasing the amount of Solid waste	Develop solid waste management program
	Absence of bags and Plastic boxes reuse	Increasing the amount of Solid waste	Develop solid waste management program
	Absence of solid waste management plans	Increasing the amount of Solid waste	Develop solid waste management program
	End of Pipe	Poor disposal of wastewater in farms and groundwater	Develop waste management program
	Absence of monitoring programs for fresh water quantity	Increasing the amount of wastewater	Develop waste management program

**Table 10: Matching causes to Product Modification option**

categories	primary cause	problem description	Cleaner production option and control measures
product modification	purity	Customer need pure olive oil that will add more processing and consume energy	Energy Audit program, adopting a photovoltaic system, investing in new production line (change technology), Waste management program.
	Color	Customer needs a specific color or pH level for olive oil that needs more processing and consumes more resources and generated waste.	Determination a specific acceptable level for olive oil color and pH level and design the extraction process to fit the requirement, technology change maybe appear here
	Ph ratio		

**Table 11: Matching Input substitution to causes**

categories	primary cause	problem description	Cleaner production option and control measures
Input substitution	Poor Quality of olives drupes	Poor quality of olives drupe consume more resources to produce specialty water for washing and electricity for processing, also generate solid waste and wastewater more than normal.	Follow the best practices for pooling and management
	Large quantity of olive leaf	A large number of olive leaves consume fresh water and produce more solid waste.	Follow the best practices for pooling and management
	Polluted freshwater	Less opportunity for reuse and get the benefits from it.	Water inspection and control
	Dusty olive drupe	Dusty olive drupes consume more resources energy and water.	Follow the best practices for pooling and management
	Production capacity	Feed the production line with less or more production capacity lead to consume more resources	Production management Plan

**Table 12: Matching causes to Recycling option**

categories	primary cause	problem description	Cleaner production option and control measures
Recycling	Absence of solid waste recycling	Poor disposal of solid waste environmental pollution	Follow Solid waste best practices
	Absence of wastewater from rinsing recycling	Poor disposal of rinsing water increase fresh water consumption	Follow rinsing water best practices
	Absence of Zibar treatment	Poor disposal of Zibar environmental pollution	Follow wastewater Zibr best practices

**Table 13: Matching causes to Technology Modification option**

categories	primary cause	problem description	Cleaner production option and control measures
Technology modification	Old production line	Consume resources more than normal, generate waste more than normal.	Change tehcnology production line
	Absence of renewable energy source	Consume large energy and electricity	Adopt a renewable energy source
	Olive oil Extraction technology	Produce a large quantity of OMW	Change tehcnology production line
	Energy efficiency technology	Consume large energy and electricity	Energy Management programs
	poor technology for water rinsing	Consume large freshwater	Adopt new technology for water rinsing

#### 4.3.2.2 Cleaner Production Option Generation:

After identifying the causes of olive mill waste generated and energy losses; cleaner production options were developed as shown in figure 25.

Each cleaner production option linked with best practices checklist developed from:

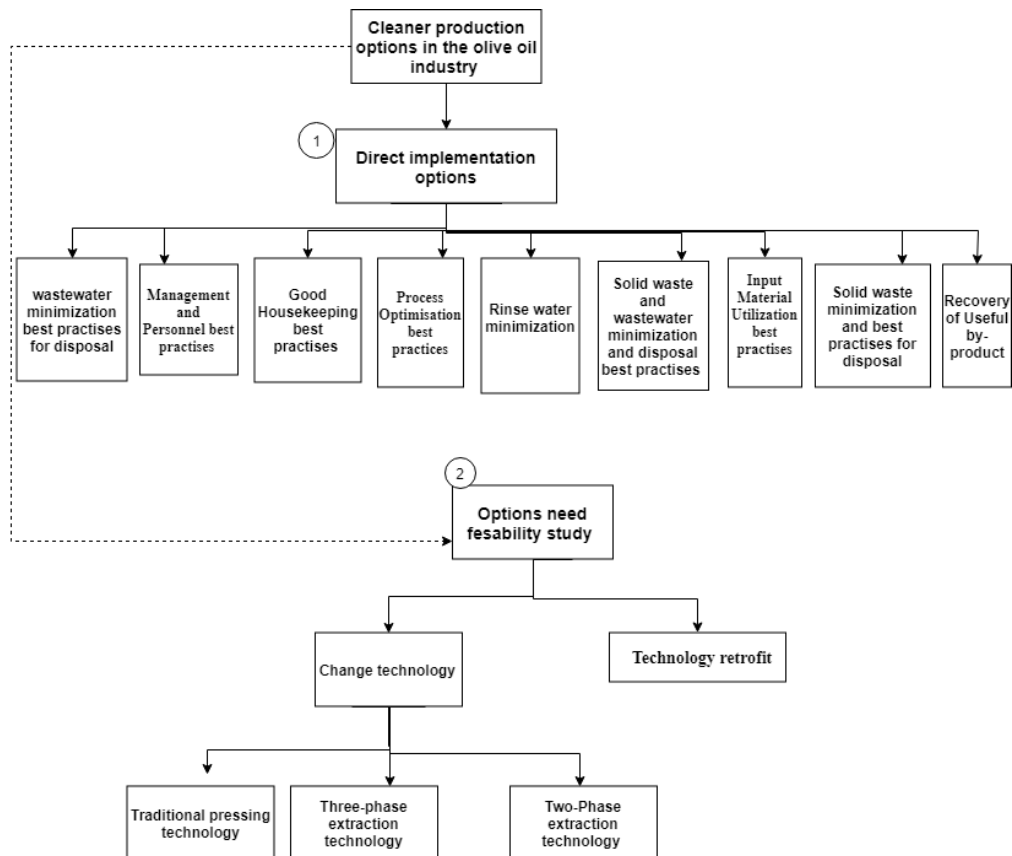
- A. semi-structured interviews with stakeholders.
- B. Literature review for the edible oil process worldwide and in Palestine.
- C. Experience from the field, we conclude it from the interviews with the ministry of health and Agriculture, and mill's managers.
- D. Discussions with the mill's Owner.

E. Examples in other companies.

F. Further research and development

G. Personal experience – walkthrough production line.

There are two categories of options developed for the olive oil industry, first categories include options that could be implemented directly in the mill without difficulty or need studies, second categories of options need more future study (feasibility study).



**Figure 26:** Cleaner Production Options for olive oil industries

Cleaner Production best practices for the olive oil industry:

### **1) Direct implementation options:**

#### **A) Management and Personnel:**

Management and personnel practices are a low-cost option. It's about how to improve employee competence, enhancing cleaner production culture into the organization. Furthermore, it is the commitment of senior managers to adopt cleaner production strategy into the organization. The best practices for management and personnel are adopted from ISO 14001:2015 [43].

#### **Table 14 Management and Personnel best practices [43,44]**

- |  |
|--|
| <ul style="list-style-type: none"> <li>- Identifying the scope of the system for example from receiving olive drop to distribution.</li> <li>- Identify organization environmental policy and objectives; by setting a smart objective for managing the waste and reducing the consumption and link it with a key performance indicator.</li> <li>- Identify employee training needs and competencies, plan for training courses and evaluation.</li> <li>- Increase the awareness between employees and farmers; how to reduce waste best practices for disposal of wastewater and using freshwater.</li> <li>- Develop an organizational structure and authority matrix.</li> <li>- Develop standard operation procedures (SOP's) to manage the production and to control and monitoring of performance.</li> <li>- Documentation control and records keeping ; for electricity and water bills and keep records of the changes in cost during months.</li> <li>- Develop a maintenance plan and procedures.</li> <li>- Develop a hygiene and sanitation program for Machin and production area.</li> <li>- Develop an environmental management system ISO 14001.</li> </ul> |
|--|

#### **B) Good Housekeeping:**

It is simply an option required no investment, could be implanted directly after options are identified. By daily inspection for production areas, the best practices for it by walkthrough organization departments and daily

monitoring procedures for control measures designed for each process. For example, turning off equipment when not needed. Good housekeeping aims to increase the efficiency of the production line, monitoring activities to detect any nonconformity of procedures with minimum losses.

The best practices for Good housekeeping from face to face interviews and from cleaner production studies made in Egypt and observation.

**Table 15: Good housekeeping best practices [42 ,43,51]**

- |   |
|---|
| <ul style="list-style-type: none"> <li>- Keep production area clean; washing for Machin and production area using a high-pressure compressor.</li> <li>- Applying Inventory management best practices for raw material.</li> <li>- Segregate solid waste and wastewater for reuse, water treatment or disposal.</li> <li>- Keep the olive oil in a stainless-steel tank to keep it fresh.</li> <li>- Keep the windows open for ventilation, and natural lights.</li> <li>- Proper material handling for olive oil and seeds.</li> <li>- Use filling Machin or develop a stop button for the filling process to avoid flooding.</li> <li>- Maintenance plan – preventive maintenance program before season.</li> <li>- Mentoring water and electricity bill each season and keep records.</li> <li>- For Three-phase decanter Use bio-mass boiler (pomace block)</li> <li>- Using thermostat in the boiler to keep the water temperature between 25-30 C.</li> <li>- Keep olive oil tanks in closed inventory avoid direct sun and high temperature.</li> <li>- Proper storage of raw materials.</li> <li>- Proper raw material handling and finished product in control.</li> <li>- Proper layout of the mill, the entrance of raw material different than the finished product and waste exit.</li> <li>- Separate washing water from production water.</li> </ul> |
|---|

### **C) Waste-water minimization**

In Olive mill two types of wastewater, first type wastewater generated from raw material washing, and rinsing water for cleaning. Second from olive oil extraction Zibar. It produced from the extraction process in three-phase mills usually separated from solid waste and oil. As previously mentioned, it's highly toxic water that causes damage to farms and groundwater. The improper disposal in Valles and empty land, not a

solution due to the high environmental impact the following ideas for wastewater reduction.

**Table 16: waste-water minimization best practices [43,44,45,46,50]**

- |   |
|---|
| <ul style="list-style-type: none"> <li>- Pooling Zibar in Sumps (isolated) to be dispose in a proper way out side mills.</li> <li>- Dispose of the Zibar by making contact with Local water-treatment plant.</li> <li>- Optimization and control of water quantity and temperature through the extraction process as the manual of the machine.</li> <li>- Change the technology of olive oil extraction from a three-phase to two-phase feasibility study should be made here to adopt this option.</li> <li>- Separate rinsing water from the extraction process water.</li> <li>- Two-phase olive mill wet sludge should be collected in Sumps and disposed of the outside mill to the water treatment plant.</li> </ul> |
|---|

#### **D) Solid Waste minimization:**

The solid waste generated in olive production from the extraction process in three-phase mills as Pomace. Also form drupes washing, packages from the pooling process. The physical characteristics after extraction are sludge it contains Zibar and pomace. The solid waste generated should be minimized and disposal in a safe way to the environment; to reduce the harmful in the environment and get benefits from it as a by-product through the following best practice table 8 show ideas for solid-waste reduction:

**Table 17: Solid-Waste minimization best practices [45, 46, 47, 48, 49, 50, 51]**

- |  |
|--|
| <ul style="list-style-type: none"> <li>- Separate pomace from Sludge to extract Pomace. Also, the best practices are, keeping the Pomace in an isolated area, collection in Agricultural lands should be avoided. The Pomace extracted by natural evaporation and collected to dispose of it as by-product or internal use as a biomass energy source.</li> <li>- Reuse bags and boxes for olive drupe pooling.</li> <li>- Collect olive leaves and reuse it as Natural fertilizer or biomass for energy.</li> <li>- A periodic maintenance plan for the decanter and hydraulic piston to ensure the efficiency of separating the pomace from oil and wastewater use the manual for production mills.</li> <li>- Control the parameters in a three-phase decanter and hydraulic piston (rotation speed, pressure force, clean the fibers in case of traditional milling) as mention in the Machin manual.</li> <li>- The solid waste sludge could be sold for the soap factory.</li> </ul> |
|--|

### **E) Process Optimization:**

This option is concerned with the production line parameter itself. All activities and action should take it into consideration to reduce waste production and resources consumption. The best practice we can follow during olive oil production is to maintain high process efficiency and sustainable as shown in the table:

**Table 18: process optimization best practices [48, 49, 50, 51, 54]**

- |   |
|---|
| <ul style="list-style-type: none"> <li>- monitoring of feeding rate of olives drupe in grinding and decanter to be at an acceptable level as mentioned in Machin Manual.</li> <li>- Optimization of hot water temperature and quantity used in the three-phase decanter as decanter capacity.</li> <li>- Periodic maintenance for sensors in the decanter (two-phase, three-phase).</li> <li>- Monitoring and adjustment of pressure load in pressing mill and rotation rate at the decanter as mention in Machin Manual.</li> <li>- Keep the fiber desk in pressing mill clean after use and reuse waste on it.</li> <li>- Adjust the number of olives drupe flow inside the decanter. It should be less than Machin's capacity as mention in maximum capacity in manual.</li> </ul> |
|---|

## **F) Rinse Water minimization:**

Freshwater used in rinse olive drupes, rinsing production lines, containers, and production areas. Best practices are to reduce consumption and to use water effectively. The following checklist table 7 show us options for water reduction knowing that it is a freshwater:

**Table 19: Rising water minimization [50, 51, 52, 55]**

- |  |
|--|
| <ul style="list-style-type: none"> <li>- Cleaning and washing production lines by using center counter rising. And high pressure of air rather than the volume of water.</li> <li>- Water flow reduction by using a stop button or a sensor to control the acceptable level of water during the washing process and with monitoring.</li> <li>- Install a monitoring system such as meter indicator and keep records.</li> <li>- Report and fix leaks promptly.</li> <li>- Using Spray Rinsing through the washing process of the olive drupes.</li> <li>- In the washing process reuse fresh water.</li> <li>- Enhance the water reuse process through a closed-loop system with a suitable filter</li> <li>- Reuse washing water from rising as input for another process such as agriculture.</li> <li>- Rising water recycle could be available but it needs a feasibility study.</li> </ul> |
|--|

## **G) Recovery of Useful by-product/resources**

Resource recovery is a concept in environmental science; focused on transferring the waste produced from production to useful products used as input to another production process. Two options for resource recovery in the olive oil extraction process, the first one the solid waste pomace after evaporation process which can be used as a biomass thermal energy source. furthermore, it could be sold to the soap factory; to extract the oil from sludge and use it in the soap industry.

In Palestine, Pomace considered a useful by-product, unlike wastewater it cost mill's owner money for disposal. On the other hand, wastewater plant generates from Zibar biomass energy and Natural fertilizer. [52, 53, 54].

### **H) Input Material Utilization:**

Input material utilization is important in this industry. It has a significant impact on the quantity of wastewater and solid waste. The two main input material in these industries are olive drupes and freshwater to ensure the best practices for them the following table 11 show the best practices rearguing olives drupes and freshwater utilization:

**Table 20: Input Material Utilization [50,51,52,53,55]**

- |  |
|--|
| <ul style="list-style-type: none"> <li>- Avoid storing the olives drupe for a long time; that will reduce the yield of oil and generate more waste.</li> <li>- Olives drupes should store and handled through plastic boxes or fiber bags to allow air inter and reduce pressure on olives drupes.</li> <li>- Separate the olives drupes pooled from the ground and drupes pooled directly from the tree; due to differences in quality and need more monitoring for waste generated.</li> <li>- Olives drupes should be collecting and pooling in plastic boxes or fiber bags.</li> <li>- Water used for washing should be treated and reuse as we mentioned before in the Rinse water best practices.</li> </ul> |
|--|

## **2) Options needed a feasibility study.**

### **A) Technology retrofit**

It is about the addition of new technology or features to existing systems the following options as shown in table 21.

**Table 21: Technology retrofit options [48, 50, 54]**

- Adapting the solar thermal cell system for heating and (photovoltaic for electricity generation system).
- Use semi-automated mills instead of the traditional manual.
- Build a well for harvesting rainwater.
- Adapt epoxy garage floor instead of cement; to consume less water during cleaning and avoid consuming high energy and water furtherer easier to reduce an effectively dispose of OMW.

**B) Technology Change and Modification:**

The change extraction process will be discussed during the feasibility study.

**4.2.4 Feasibility Study:**

The feasibility study was conducted to evaluate the change technology option between three different olive oil extraction technology, the purpose is to determine the suitable and optimum option to adopt the following parameters were considered during evaluation: technical evaluation, economic evaluation, and environmental evaluation.

**4.2.4.1 Criterion weight determination**

- Technical Feasibility Criteria:

One to one interview was conducted with three different sectors; to determine the optimum Weights for each criterion table 22 summaries the results and the average of each criterion was the final weight for technical feasibility.

**Table 22: Technical Feasibility Criteria interview results**

Technical	Criterion	Score			
		Ministry of Environmental Affairs	Ministry of agriculture	Local Compan	Average
1	Pomace/by-product quality.	3	3	3	3
2	Human resources and staff requirement.	1	2	1	1
3	Occupational health and safety.	1	1	2	1
4	Product specification ( color, taste, ph number).	2	3	3	3
5	Easy installation and implementation.	1	2	3	2
6	Time needs for implementation	1	1	3	2
7	social aspects	1	1	3	2

The scale used from plus 3 to minus 3 whereas the plus for positive impact and minus for negative impact.

- Environmental feasibility criteria:

For the environmental also One to one interview was conducted with three different sectors; to determine the weight for each criterion table 23 summaries the results and the average of each criterion was the final weight for Environmental feasibility.

**Table 23: Environmental Feasibility Criteria interview results**

Environmental	Criterion	Score			
		Ministry of Environmental Affairs	Ministry of agriculture	Local Company	Average
1	The amount of wastewater (Zber).	3	3	3	3
2	The amount in solid-waste generation	3	2	2	2
3	freshwater (used for washing and rinsing water).	3	3	3	3
4	The amount of energy used	3	3	2	3
5	The capability of adopting and utilizing rain water harvesting system	3	2	1	2
6	The capability of adopting and utilizing renewable energy, resources	2	2	2	2
7	Waste water treatment opportunity	3	3	2	3

The scale used from plus 3 to minus 3 whereas the plus for positive impact and minus for negative impact.

- Economic feasibility:

Three methods were adopted for economic evaluation each method represents an indicator for financing investment and any of them could be used to make the investment decision regarding financial issues, Payback period method is recommended to use.

**Table 24: Economic feasibility accepting criteria**

Economic	Criterion	Score			
		Ministry of Environmental Affairs	Ministry of agriculture	Local Compan	Average
1	The optimum pay back period (PBP) for olive oil extraction mill	4 years	3 years	3 years	3 years
2	Net present value (NPV)	Positive	Positive	Positive	Positive
3	Internal rate of return (IRR)	It depend on cash flow	It depend on cash flow	It depend on cash flow	It depend on cash flow

#### 4.2.4.2 Assigning the scores for each criterion:

After determining the criteria weights, a feasibility study was made to decide which technology is feasible to adopt in Palestine for the olive oil extraction process.

- Environmental evaluation assigning score:

1) The amount of wastewater (Zibar).

**Table 25: The amount of wastewater (Zibar) [32]**

Z = The amount of wastewater (Zibar). / Reference 1000 kg olives drupes	Score negative impact
$Z \leq 400$ L Two- Phase decanter	-1
$4000 \leq Z \leq 600$ L Traditional olive mill	-2
$Z > 600$ L Three-phase Decanter	-3

- 2) The amount of solid waste generated in producing 1000 kg of olives.

**Table 26: The amount of solid waste generated [32]**

S = The amount in solid-waste generation / Reference 1000 kg olives drupes		Score negative impact
$S \leq 400$ kg	Two-Phase Decanter	-1
$400 \leq S \leq 600$ kg	Three-Phase Decanter and Traditional olive mill	-2
$S > 600$ kg	Non	-3

- 3) Freshwater (used for washing and rinsing water) in producing 1000 kg of olives.

**Table 27: Freshwater (used for washing and rinsing water) [32]**

F = freshwater (used for washing and rinsing water). / Reference 1000 kg olives drupes		Score negative impact
$F < 120$ -liter	Two-phase Decanter and Traditional olive mill	-1
$120 \leq F \leq 700$ liter	Non	-2
$F > 700$ liter	Three-Phase Decanter	-3

- 4) The amount of energy used in production 1000 Kg of olives.

**Table 28: The amount of energy used in production as acceptable levels**

E = The amount of energy used / Reference 1000 kg olives drupes		Score negative impact
$E < 60$ kWh	Traditional pressing mill	-1
$60 \leq E \leq 90$ kWh	Two-Phase Decanter	-2
$E > 90$ kWh	Three-phase Decanter	-3

5) The capability of adopting and utilizing rainwater harvesting system

**Table 29: capability of adopting and utilizing rainwater harvesting system**

The capability of adopting and utilizing rainwater harvesting system		Score a positive impact
No Need	Traditional pressing mill	1
Not Capable	Non	2
Capable decanter	Two-phase Decanter and Three-phase	3

6) The capability of adopting and utilizing renewable energy, resources

**Table 30: capability of adopting and utilizing renewable energy**

The capability of adopting and utilizing renewable energy resources		Score a positive impact
Not Capable	Traditional pressing mill	1
No Need	Non	2
Capable	Two-phase Decanter and Three-phase decanter	3

7) water treatment opportunity

**Table 31: water treatment opportunity**

The capability of adopting Wastewater treatment opportunity		Score a positive impact
Not Capable	Traditional pressing mill	1
No Need	Non	2
Capable	Three-phase and two-phase decanter	3

**Table 32: Environmental evaluation**

Number	Criteria for Environmental evaluation	Technology Type		
		Three-Phase decanter	Two phase Decanter	Traditional pressing mill
1	The amount of wastewater (Zbar).	-3	-1	-2
2	The amount in solid-waste generation	-2	-1	-2
3	freshwater (used for washing and rinsing water).	-3	-1	-1
4	The amount of energy used	-3	-2	-1
5	The capability of adopting and utilizing rain water harvesting system	3	3	1
6	The capability of adopting and utilizing renewable energy, resources	3	3	1
7	Waste water treatment opportunity	3	3	1

- Technical evaluation assigning scores:

1) Pomace /by-product quality.

**Table 33: Olive oil Quality [34]**

Product/by-product quality.	Score a positive impact
low Quality - Non	1
Medium Quality - Traditional olive mill and Three phase decanter	2
High-Quality - Two-phase decanter	3

2) Human resources and staff requirement.

**Table 34: Human resources and staff requirement [34].**

Human resources and staff requirement.	Score negative impact
Low number of employees - Two-phase and three-phase decanter.	-1
Medium number of employees Non	-2
High number of employee Traditional pressing mill	-3

3) Occupational health and safety.

**Table 35: Occupational health and safety [34].**

Occupational health and safety	Score negative impact
Low percentage of accidents - Three-phase and Two-phase decanter	-1
Medium percentage of accidents Non	-2
High percentage of accidents - Traditional pressing mill	-3

4) Product specification (color, taste, ph. number).

**Table 36: Product specification (color, taste, Ph number). [34]**

Product/by-product quality.	Score a positive impact
Low Quality - traditional olive mill	1
Medium Quality - three-phase	2
High-Quality - two-phase decanter	3

5) Easy installation and implementation.

**Table 37: Easy installation and implementation [34]**

Easy installation and implementation.	Score a positive impact
Hard - traditional pressing mill	1
Medium	2
Easy two-phase decanter, Three-phase	3

6) Time needs for implementation

**Table 38: Time needs for implementation [34].**

Time needs for implementation	The score of negative Impact
Fast Two -Phase and Three-Phase decanter	-1
Medium time Non	-2
Slow Traditional pressing mill	-3

7) Social aspects

**Table 39: social aspects [34]**

Social aspects	Score a positive impact
Not Desired Two-phase decanter	1
Acceptable Traditional olive mill	2
Desired Three-phase decanter	3

## Technical evaluation Results.

**Table 40: Technical Evaluation**

Number	Criteria for Technical option	Technology Type		
		Three-Phase decanter	Two phase Decanter	Traditional pressing mill
1	Pomace -product quality.	3	1	2
2	Human resources and staff requirement.	-1	-1	-3
3	Occupational health and safety.	-1	-1	-3
4	Product specification ( color, taste, ph number).	2	3	1
5	Easy installation and implementation.	3	3	1
6	Time needs for implementation	-1	-1	-3
7	social aspects	3	1	2

### - Economic Evaluation.

payback period (PBP)

PBP was adopted during the study and it is the amount of time taken by the Mill Owners to recover the initial investment of new production lines after changing the technology.

**Table 41: payback period (PBP) [41]**

P = payback period (PBP) - number is years	Score
$6 > p$	1
$3 < P \leq 6$	2
$P \leq 3$	3

Payback period recommended to use for economic feasibility to selecting the optimum extraction technology due to easy to be a benchmark and make comparison between three types of technology to make this a cash flow should be calculated for season and the investment cost for each new production line should be determined to take into account the cost of shipping, the country of origin and the production capacity .

- *feasibility evaluation.*

Technical evaluation for technology change option:

**Table 42: Technical evaluation**

Number	Criteria for Technical option total 30%	Weight	Options					
			Three-Phase Decanter		Two-Phase Decanter		Traditional pressing Mill	
			score	weighted score	score	weighted score	score	weighted score
1	Pomace/by-product quality.	3	3	9	1	3	2	6
2	Human resources and staff requirement.	-1	-1	1	-1	1	-3	3
3	Occupational health and safety.	-1	-1	1	-1	1	-3	3
4	Product specification ( color, taste, ph number).	3	2	6	3	9	1	3
5	Easy installation and implementation.	2	3	6	3	6	1	2
6	Time needs for implementation	-2	-1	2	-1	2	-3	6
7	social aspects	2	3	6	1	2	2	4
	Total		8		5		-3	

Three-phase decanter has the highest score to be adopted in Palestine regarding technical aspects followed by the two-phase decanter extraction process.

Environmental evaluation.

**Table 43: Environmental evaluation.**

Number	Criteria for Environmental evaluation option total 35%	Weight	Options					
			Three-Phase decanter		Two phase Decanter		Traditional pressing mill	
			score	weighted score	score	weighted score	score	weighted score
1	The amount of wastewater (Ziber).	-3	3	-9	1	-3	2	-6
2	The amount in solid-waste generation	-2	2	-4	1	-2	2	-4
3	freshwater (used for washing and rinsing water).	-3	3	-9	1	-3	1	-3
4	The amount of energy used	-3	3	-9	2	-6	1	-3
5	The capability of adopting and utilizing rain water harvesting system	2	3	6	3	6	1	2
6	The capability of adopting and utilizing renewable energy, resources	2	3	6	3	6	1	2
7	water treatment opportunity	3	3	9	3	9	1	3
	Total Score			-10		7		-9

Two-phase decanter can be considered environmentally friendly and less harmful to the environment and has a positive score against other technology.

#### **4.3.4 Implementation and Continuous Improvement**

After option generation, two types of options generated the first could be direct implements and adopted by the organization with minimum cost and efforts. The second group needs a feasibility study. The organization should identify the priority of implementation of the options in case they have many options generated and need more future study.

##### **4.3.4.1 Prioritization of Cleaner Production Option**

To choose the most feasible option, prioritization of cleaner production was used:

the weighted average method used to select the highest score to adapted as a final cleaner production option. In this method, weights to each of the three aspects of the feasibility analysis (technical feasibility, economic viability, environmental performance) were assigned.

From the investigation in the olive oil production process and conclusions from literature, semi-structured interviews, brainstorming with the research supervisor, find the following weight was given:

**Table 44: Feasibility weighting**

Number	evaluation Criterion	Ministry of Environmental Affairs	Ministry of agriculture	Local Company	Average
1	Environmental	40%	35%	30%	35%
2	Technical	30%	35%	35%	34%
3	Economic	30%	30%	35%	31%

The Methodology for Prioritization Options:

$$F = E + T + C$$

Where,

F= The Total option score from Environmental Feasibility, technical feasibility, and economic feasibility.

E= Environmental feasibility score.

T= Technical feasibility score.

C= Economic feasibility score.

F= (Score from environmental \*0.35 + Score from technical \*0.34+ score from Economic \*0.31).

**Table 45: how to assign a rank for prioritization**

F = option score from feasibility assessment	Prioritization score
$F \leq 0$	0
$0 \leq F \leq 15$	1
$15 \leq F \leq 30$	2
$30 \leq F$	3

#### **4.3.4.2 Developing a Cleaner Production Plan:**

An implementation plan to adopting and execution through the timeline should be determined. The following points should be considered during assigning the implementation plan.

- 1) The investment needed for each option and human resource training needs.
- 2) Commitment from management to adopt the project.
- 3) Assigning tasks, time frames, and responsibilities.
- 4) The easy option takes the priorities to implementation, and low cost then moves to other options upon priority matrix.

#### **4.3.4.2 Continuous Improvement**

After the implementation of cleaner production techniques into the organization and adopted the cleaner production options, many changes in the organization will occur. It should reflect an organization's vision, policy, and standard operation procedures, so the concept of cleaner production should be integrated with all company management systems and continually reviewed for improvement and validation and verification activities should be conducted through monitoring the bills of consumption, the waste quantity, and internal audit programs.

## **Chapter 5**

### **Conclusion**

Improper disposal of olive mill waste through valleys has significant damage to environments and groundwater knowing that high concentrate organic and phenols component has the potential to pollute drinking water and pollution soil in Palestine. It also lacks the best practices from mill owners to increase the probability of pollution. Cleaner production options and best practices had taken place in this study to manage the disposal process and reduce the effect of black-water and solid waste this occurred mainly during the olive season from October to December.

Based on the interview with stockholders and walkthrough, olive mills in west-bank general characteristics of OMW, and material balance analysis for input and output material it was concluded that the need for an environmental management system to manage the OMW in Palestine and its definition. Different cleaner production options have been presented and elaborated. An evaluation tool was developed to grade and rank cleaner production options to seat the priority to implementation. Also, the feasibility study tool had taken place (environmental, technical and economic feasibility) to decide the ability to apply the option in this industry.

The management and treatment options should be environmentally friendly to reduce OMW. The olive-mills management system has been analyzed from harvesting to end-of-pipe. We find the following in west-bank:

- 1) Three-phase decanter is the most popular techniques used due to less work needed to run it, less experience and moderate investment cost needed as well. The byproduct from it (pomace) is useful for biogas and profit to organization furthered easier to dispose of it.
- 2) Two-phase decanter not desired from farmers and mill's owner high investment cost. A more qualified worker is needed, and no by-product Pomace could be sold as salvage value. High disposal cost for wet sludge.
- 3) The traditional pressing three-phase mill is old technology that needs many workers and has less productivity and efficiency of olive oil and in Palestine, this technology is disappearing.
- 4) An awareness campaign should be considered from the government to farmers and olive mill owners regarding the best practice of OMW and put regulation and standard for it.
- 5) Minimum requirement and practices could be implemented in mills will reduce the waste generated and reduce the cost of water and energy consumption.
- 6) Good housekeeping and Management system could be helpful to avoid harmful environmental impact and with low investment costs.
- 7) Three-phase considered technical accepted in Palestine and the most popular technology but environmental consider harmful and has a negative environmental impact.

## References

- 1- “Resource Efficient and Cleaner Production.” **UNEP DTIE SCP Branch: Resource Efficient and Cleaner Production.** UNEP. Accessed December 16, 2018. <http://www.unep.fr/scp/cp/>.
- 2- “**UNIDO INVESTMENT PROMOTION** - United Nations Industrial ...” [www.unido.org](http://www.unido.org). UNEP. Accessed December 1, 2018. [https://tii.unido.org/sites/default/files/publications/Investment brochure\\_FINAL.pdf](https://tii.unido.org/sites/default/files/publications/Investment%20brochure_FINAL.pdf).
- 3- Matos, Lucas Marques, Rosley Anholon, Dirceu Da Silva, Robert Eduardo Cooper Ordoñez, Osvaldo Luiz Gonçalves Quelhas, *Walter Leal Filho, and Luis Antonio De Santa-Eulalia*. “Implementation of Cleaner Production: A Ten-Year Retrospective on Benefits and Difficulties Found.” **Journal of Cleaner Production** 187 (2018): 409–20. <https://doi.org/10.1016/j.jclepro.2018.03.181>.
- 4- Bot, Arjen, and Eckhard Flöter. “**Application of Edible Oils.**” *Edible Oil Processing*, April 2013, 223–49. <https://doi.org/10.1002/9781118535202.ch8>.
- 5- Joe, Parcell. “*Global Edible Vegetable Oil Market Trends.*” **Biomedical Journal of Scientific & Technical Research** 2, no. 1 (2018). <https://doi.org/10.26717/bjstr.2018.02.000680>.

- 6- Jegede, Abayomi. “**Top 10 Largest Oil Seeds Producing Countries In The World.**” *The Daily Records*. The Daily Records, January 1, 2019. <http://www.thedailyrecords.com/2018-2019-2020-2021/world-famous-top-10-list/world/largest-oil-seeds-producing-countries-world-10-top/6855/>.
- 7- Greyt, Wim De. “**Edible Oil Refining: Current and Future Technologies.**” *Edible Oil Processing*, April 2013, 127–51. <https://doi.org/10.1002/9781118535202.ch5>.
- 8- Juan, M. Emília, Uwe Wenzel, Hannelore Daniel, and Joana M. Planas. “**Olive Fruit Extracts and HT-29 Human Colon Cancer Cells.**” *Olives and Olive Oil in Health and Disease Prevention*, 2010, 1301–10. <https://doi.org/10.1016/b978-0-12-374420-3.00145-5>.
- 9- “The Current Status of Industrial Sector in Palestine .” *The Current Status of Industrial Sector in Palestine* . USAID. Accessed December 25, 2018. [https://www.ppu.edu/ppuittc/sites/default/files/The Current Status of the Industrial Sector in Palestine.pdf](https://www.ppu.edu/ppuittc/sites/default/files/The%20Current%20Status%20of%20the%20Industrial%20Sector%20in%20Palestine.pdf).
- 10- “إنتاج نشاط معاصر الزيتون في فلسطين حسب المحافظة، 2017” <http://www.pcbs.gov.ps/>. PCBS. Accessed December 27, 2018. [http://www.pcbs.gov.ps/Portals/Rainbow/Documents/a\\_output\\_press\\_2017.html](http://www.pcbs.gov.ps/Portals/Rainbow/Documents/a_output_press_2017.html).

11- , Arij. “The Food Industry Sector in the West Bank.” **Visit Arij.org! The Applied Research Institute - Jerusalem (ARIJ)**. Accessed December 28, 2018. <http://www.arij.org/latest-news/210-publications/food-market-assessments/baseline-surveys/672-the-food-industry-sector-in-the-west-bank.html>.

12- Erakat, Noura, and Marc Lamont Hill. “*Black-Palestinian Transnational Solidarity: Renewals, Returns, and Practice.*” **Journal of Palestine Studies** 48, no. 4 (January 2019): 7–16. <https://doi.org/10.1525/jps.2019.48.4.7>.

13- “**Environmental Protection & Sustainable Development in Palestine.**” <https://www.arij.org/>. the Applied Research Institute - Jerusalem (ARIJ) / Society. Accessed December 29, 2018. [http://www.arij.org/files/admin/Environmental\\_Protection\\_Sustainable\\_Development\\_in\\_Palestine.pdf](http://www.arij.org/files/admin/Environmental_Protection_Sustainable_Development_in_Palestine.pdf).

14- “**Status of Environment in the State of Palestine - 2015.**” <https://www.arij.org/>. Arij. Accessed December 29, 2018. [https://www.arij.org/files/arijadmin/2016/Final\\_SOER\\_2015\\_opt\\_r.pdf](https://www.arij.org/files/arijadmin/2016/Final_SOER_2015_opt_r.pdf).

15- Hung, Yung-Tse, Hana Salman, and Adel Awad. “**Olive Oil Waste Treatment.**” *Waste Treatment in the Food Processing Industry*, 2005, 119–92. <https://doi.org/10.1201/9781420037128.ch5>.

16- Coca-Prados, José, and Gemma Gutiérrez-Cervelló. **“Economic Sustainability and Environmental Protection in Mediterranean Countries through Clean Manufacturing Methods.”** NATO Science for Peace and Security Series C: Environmental Security, 2013. <https://doi.org/10.1007/978-94-007-5079-1>.

17- “<https://www.unido.org/>.” *https://www.unido.org/*. **The UNIDO–UNEP National Cleaner Production Centres**, 2010. [https://www.unido.org/sites/default/files/2010-11/Taking stock and moving forward-November2010\\_0.pdf](https://www.unido.org/sites/default/files/2010-11/Taking%20stock%20and%20moving%20forward-November2010_0.pdf).

18- van Berkel,, René. **“Introduction to Cleaner Production Assessments with Applications in the Food Processing Industry.”** Introduction to Cleaner Production Assessments with Applications in the Food Processing Industry, 1995. <https://p2infohouse.org/ref/01/00435.pdf>.

19- Bai, Shuo-Wei, Jin-Sheng Zhang, and Zhi Wang. **“A Methodology for Evaluating Cleaner Production in the Stone Processing Industry: Case Study of a Shandong Stone Processing Firm.”** *Journal of Cleaner Production* 102 (2015): 461–76.

<https://doi.org/10.1016/j.jclepro.2015.04.139>.

20- Boltic, Zorana, Nenad Ruzic, Mica Jovanovic, Marina Savic, Jovan Jovanovic, and Slobodan Petrovic. “*Cleaner Production Aspects of Tablet Coating Process in Pharmaceutical Industry: Problem of VOCs Emission.*” **Journal of Cleaner Production** 44 (2013): 123–32. <https://doi.org/10.1016/j.jclepro.2013.01.004>.

21- Oreja-Rodríguez, Juan Ramón, and Yaiza Armas-Cruz. “*Environmental Performance in the Hotel Sector: the Case of the Western Canary Islands.*” **Journal of Cleaner Production** 29-30 (2012): 64–72. <https://doi.org/10.1016/j.jclepro.2012.02.012>

22- Costa, Nelma Penha Da, José Francisco Prado Filho, and Alberto Fonseca. “**Cleaner Production Implementation In The Textile Sector: The Case Of A Medium-Sized Industry In Minas Gerais.**” *Revista Eletrônica Em Gestão, Educação e Tecnologia Ambiental* 21, no. 3 (2017): 222. <https://doi.org/10.5902/2236117029373>.

23- Wiedemann, S.g., E.j. Mcgahan, and C.m. Murphy. “*Resource Use and Environmental Impacts from Australian Chicken Meat Production.*” **Journal of Cleaner Production** 140 (2017): 675–84. <https://doi.org/10.1016/j.jclepro.2016.06.086>.

24- “**Cleaner Production Assessment in Meat Processing.**” [www.unep.fr](http://www.unep.fr). Accessed January 12, 2019.

<http://www.unep.fr/shared/publications/pdf/2482-CPmeat.pdf>.

- 25- "**Cleaner production practices in Egyptian edible oil and soap industry**," in Proceedings of International Symposium and Workshop on Environmental Pollution Control and Waste Management, Tunis, 2002.
- 26- Choong, Chee Guan, and Alison McKay. "***Sustainability in the Malaysian Palm Oil Industry.***" **Journal of Cleaner Production** 85 (2014): 258–64. <https://doi.org/10.1016/j.jclepro.2013.12.009>.
- 27- Rudina Çakraj<sup>1</sup>, Donika Prifti<sup>2</sup>., "http://www.ishp.gov.al," <http://www.ishp.gov.al>, 28 7 2018. [Online]. Available: <http://www.ishp.gov.al/resource-efficiency-and-cleaner-production-in-the-olive-oil-industry-cakraj/>. [Accessed 29 6 2019].
- 28- Hocaoglu, Selda Murat, Betul Hande Gursoy Haksevenler, Irfan Basturk, Pamir Talazan, and Cihangir Aydoner. "***Assessment of Technology Modification for Olive Oil Sector through Mass Balance: A Case Study for Turkey.***" **Journal of Cleaner Production** 188 (2018): 786–95. <https://doi.org/10.1016/j.jclepro.2018.04.020>
- 29- UNEP, UNIDO. "**How to Establish a Cleaner Production Centre.**" <http://www.unep.fr/>. UNIDO/UNEP. Accessed December 22, 2018. [http://www.unep.fr/shared/publications/other/WEBx0072xPA/manual\\_cdrom/Guidance Manual/PDF versions/Part3.pdf](http://www.unep.fr/shared/publications/other/WEBx0072xPA/manual_cdrom/Guidance%20Manual/PDF%20versions/Part3.pdf).

30- **“Resource Efficient and Cleaner Production Programme for Myanmar Introduced by UNIDO with Swiss Funding.”** UNIDO. Accessed January 20, 2019. <https://www.unido.org/news/resource-efficient-and-cleaner-production-programme-myanmar-introduced-unido-swiss-funding>.

31- **“POLLUTION PREVENTION IN OLIVE OIL PRODUCTION.”** EPA. Environmental Protection Agency, August 14, 2015. [https://cfpub.epa.gov/ncer\\_abstracts/index.cfm/fuseaction/display.abstractDetail/abstract/9859/report/F](https://cfpub.epa.gov/ncer_abstracts/index.cfm/fuseaction/display.abstractDetail/abstract/9859/report/F).

32- Nilsson, Lennart. **Cleaner Production: Technologies and Tools for Resource Efficient Production.** Uppsala: Baltic University Press, 2007.

33- Kaddani, Sami, Daniel Vanderpooten, Jean-Michel Vanpeperstraete, and Hassene Aissi. ***“Weighted Sum Model with Partial Preference Information: Application to Multi-Objective Optimization.”*** **European Journal of Operational Research** 260, no. 2 (2017): 665–79. <https://doi.org/10.1016/j.ejor.2017.01.003>.

34- Khdair, Adnan I., Salam Ayoub, and Ghaida Abu-Rumman. ***“Effect of Pressing Techniques on Olive Oil Quality.”*** **American Journal of Food Technology** 10, no. 4 (January 2015): 176–83.

35- <https://doi.org/10.3923/ajft.2015.176.183>.

- 36- Abdel-Karim, Riyad, and Hafez Shaheen. “**An - Najah Univ. J. Res. (N. Sc.) Vol. 21, 2007.**” blogs.najah.edu. Accessed February 20, 2019. [https://blogs.najah.edu/staff/emp\\_3006/article/Management-of-Olive-Mills-Wastewater-in-Palestine/file/313.pdf](https://blogs.najah.edu/staff/emp_3006/article/Management-of-Olive-Mills-Wastewater-in-Palestine/file/313.pdf).
- 37- Dermeche, S., M. Nadour, C. Larroche, F. Moulti-Mati, and P. Michaud. “**Olive Mill Wastes: Biochemical Characterizations and Valorization Strategies.**” Process Biochemistry 48, no. 10 (2013): 1532–52. <https://doi.org/10.1016/j.procbio.2013.07.010>.
- 38- “**First Steps to Green Competitiveness Guidebook.**” enterprise-ireland. enterprise-ireland. Accessed March 20, 2019. <https://www.enterprise-ireland.com/en/funding-supports/Company/Eestablish-SME-Funding/LeanStart-Environmental-Guidelines.pdf>.
- 39- قطاع المياه مجلس تنظيم. “**الطريق إلى الاستدامة تقرير أداء مقدمي خدمات المياه والصرف**” WSRC. مجلس تنظيم قطاع المياه فلسطين. Accessed June 4, 2019. <https://www.wsrc.ps/ar>.
- 40- “**الشمال شركة كهرباء.**” أسعار الكهرباء في فلسطين nedco. Accessed April 20, 2019. <http://www.nedco.ps/?ID=620>.
- 41- “**المالكي ايمان.**” جفت الزيتون.. مصدر رزق ووقود طبيعي aliqtisadi. aliqtisadi, October 91, 2017. <https://www.alestqlal.com/post/17977>.
- 42- Mr.Ayman. Laham, Interviewee, **financial auditor**.date. 16 9 2019.

43- Kumbi Mugwindiri<sup>1</sup>, Ignatio Madanhire<sup>2</sup>, Tapiwa Masiwa<sup>3</sup>, "***Design of a Cleaner Production Framework for Engineering Company: DrinkCo Beverages,***" **International Journal of Science and Research (IJSR)**, , vol. 2, no. 2, pp. 1-17, 2013.

44- Planners AS, Denmark, COWI Consulting Engineers. "**Cleaner Production Assessment in Meat Processing.**" UNEP, 2015. <http://www.unep.fr/shared/publications/pdf/2482-CPmeat.pdf>.

45- Masango, Phineas. "**Cleaner Production of Essential Oils by Steam Distillation.**" **Journal of Cleaner Production** 13, no. 8 (2005): 833–39. <https://doi.org/10.1016/j.jclepro.2004.02.039>.

46- Wiesman, Zeev. "**Olive-Mill Wastes: Treatment and Product Biotechnologies.**" *Desert Olive Oil Cultivation*, 2009, 243–55. <https://doi.org/10.1016/b978-0-12-374257-5.00010-5>.

47- Shamma, Nazih. "**Characteristics of Hazardous Industrial Waste.**" *Advances in Industrial and Hazardous Wastes Treatment Handbook of Advanced Industrial and Hazardous Wastes Treatment*, April 2009, 485–517. <https://doi.org/10.1201/9781420072228-c13>.

48- Borja, R., A. Martin, R. Maestro, J. Alba, and J.a. Fiestas. "**Enhancement of the Anaerobic Digestion of Olive Mill Wastewater by the Removal of Phenolic Inhibitors.**" *Process Biochemistry* 27, no. 4 (1992): 231–37. [https://doi.org/10.1016/0032-9592\(92\)80023-v](https://doi.org/10.1016/0032-9592(92)80023-v).

49- Dermeche, S., M. Nadour, C. Larroche, F. Moulti-Mati, and P. Michaud. **“Olive Mill Wastes: Biochemical Characterizations and Valorization Strategies.”** *Process Biochemistry* 48, no. 10 (2013): 1532–52. <https://doi.org/10.1016/j.procbio.2013.07.010>

50- Christoforou, Elias, and Paris A. Fokaides. **“A Review of Olive Mill Solid Wastes to Energy Utilization Techniques.”** *Waste Management* 49 (2016): 346–63. <https://doi.org/10.1016/j.wasman.2016.01.012>.

51- Amjad Al Kharraz, Interviewee, **Manager of Ministry of Environmental Affairs Nablus office.** [Interview]. 14/3/2019 3 2019

52- Pepe, Francesco. **“Environmental Impact of The Disposal Of Solid By-Products From Municipal Solid Waste Incineration Processes.”** *Environmental Geochemistry*, 2008, 317–32. <https://doi.org/10.1016/b978-0-444-53159-9.00013-9>.

53- Majdi. w. Kukhon, Interviewee, **ministry of agriculture Nablus office Manage.** [Interview]. 5/3/2019 3 2019.

54- I. I. S. organization, **“Support,”** in *ISO 14001:2015 ENVIRONMENTAL MANAGEMENT SYSTEM.*

55- **IMPLEMENTATION GUIDE**, switzerland, ISO International , 2015, pp. 20-22.

56- S. I. A. ELELA, "**Cleaner production practices in Egyptian edible oil and soap industry,**" in Proceedings of International Symposium and Workshop on Environmental Pollution Control and Waste Management, 7-10 January 2002, Tunis (EPCOWM'2002), p.249-257., 2002.

57- D. S. Jarar, Interviewee, **Good housekeeping for olive oil industry.** [Interview]. 12 8 2019.

## Appendices

### Appendix I

#### List of companies, institution and expert's response to the survey

العنوان	اسم الشخص الذي تم مقابلتة	اسم الشركة او الجهة المعنية	القطاع
كفر قدوم	السيد عبد الحميد طه صاحب المعصرة	معصرة كفر قدوم الحديثة	المصانع والمعاصر
محافظة طولكرم -علا	السيد وائل شديد مدير وصاحب المعصرة	معصرة علا الحديثة	
رام الله عارورا	السيد انور صالح صاحب المعصرة	مصعرة عارورا	
محافظة سلفيت	السيد عبد العزيز المصري مدير المعصرة	معصرة سلفيت	
محافظة نابلس	السيد ابو حسام الجندي	معصرة الجندي	
محافظة جنين	المهندس عنان مدير الانتاج في المصنع	شركة كنعان لصناعة الزيت	
محافظة نابلس	المهندس ايمن ابو غزالة قائم ياعمال مدير عام المصنع	شركة الزيوت النباتية والسمنة	
محافظة نابلس	السيد زياد عنبتاوي	شركة العنبتاوي لاستيراد وتعبئة الزيوت	
محافظة طولكرم -علا	السيد فياض فياض رئيس مجلس الزيت	مجلس الزيت	
محافظة نابلس	المهندس مجدي الخراز مدير مكتب سلطة جودة البيئة	سلطة جودة البيئة	
محافظة جنين	(1) الدكتور زياد فضة- مدير الابحاث البيئية وزارة الزراعة.	وزارة الزراعة	
محافظة نابلس	(2) الاستاذ وجدي الكخن مدير عام مكتب وزارة الزراعة.		
محافظة جنين	(3) الباحثة امية حماد وزارة الزراعة.		
محافظة نابلس	(4) مسؤول تسمم اليزيتون السيدة احلام الصدر.		
محافظة نابلس	(5) السيد محمد عاشور قسم البستنه .		
محافظة نابلس	الدكتور .عبد الفتاح الملاح	جامعة النجاح	الاكاديمي
بلدية بيرزيت	الدكتور عفيف حسن	جامعة بيرزيت	

## Appendix II

### Interview- equations

تقييم وجهات النظر والتحديات المتعلقة في تطبيق معايير الانتاج النظيف بقطاع الزيوت

والسمنه النباتية في فلسطين

بروتوكول المقابلة – المؤسسات الحكومية والمؤسسات الخاصة والنقابات العاملة في فلسطين ضمن هذا القطاع

المحور الاول : معلومات عامة

	اسم المؤسسة :
	اسم الشخص المقابل :
	المسمى الوظيفي :
	الخبره في المؤسسة :
	اليوم :
	الساعة :
	السوق الخاص في منجاتكم
	عدد العاملين بالشركه
	اخر تحديث لخطوط الانتاج

صباح الخير/ مساء الخير

بداية اود ان أشكركم على استجابتكم لتبليية دعوتنا في المقابلة.

واسمحوا لي بداية أن أقوم بالتعريف عن نفسي انا المهندس نشأت عثمان طالب دراسات عليا في برنامج مشترك بين جامعة بيرزيت وجامعة النجاح برنامج هندسة الاستدامة في الانتاج وهذا الاستبيان هو لاستكمال متطلب اطروحة تخرج في مجال تقييم مستوى تطبيق معايير الانتاج النظيف في قطاع صناعة الزيوت بفلسطين.

الهدف من الدراسة: تهدف هذه الدراسة إلى تقييم الوعي وجمع معلومات في مفهوم وتطبيق معايير الانتاج النظيف في قطاع الزيوت بفلسطين من قبل الجهات الحكومية والاكاديمية والصناعة ، وتحديد أهم التحديات التي تواجه امكانية تطبيق الانتاج النظيف والفرص للتطوير القطاع المستهدف وفقا لوجهات النظر المختلفة من قبل الجهات المستهدفة في الدراسة.

ضمان السرية: سيتم التعامل مع هذه المعلومات بسرية تامة ولن يتم ذكر اسم المؤسسة او ما قد يدل عليها من قريب او بعيد او افشاء معلومات خاصة بالمؤسسة.

المدة الزمنية للمقابلة: قد تستغرق هذه المقابلة ما مدته 20-40 دقيقة.

المحور الثالث الأسئلة

هل توافق على تعريف الانتاج النظيف :

الانتاج الانظف :

هو تطبيق مستمر لاستراتيجية وقانية تشمل عمليات التصنيع والتسويق والخدمات، وتهدف الى زيادة الكفاءة والتقليل من الأخطار التي تلحق بصحة الانسان وبالبيئة.

A. هل هنالك اي مواصفات فلسطينية تعنى في ترشيد استهلاك المياه، والطاقة وادارة النفايات الصلبة الخاصة في قطاع الزيوت في فلسطين للمصانع والمعاصر بشكل خاص.

B. ما هو عدد المصانع الخاصة في انتاج الزيت والمعاصر الحاصلة على شهادات الجودة العالمية ISO 14001 , ISO 2200 في الضفة الغربية .

C. ما هي أبرز النشاطات ( ندوات، مؤتمرات، مشاريع، أبحاث، ورش عمل، المشاركة في وضع سياسات أو مواصفات) التي قامت بها مؤسستكم أو مخطط أن تقوم بها فيما يتعلق بالاستخدام المستدام للطاقة، المياه، المواد، البيئة والتلوث؟

1- الطاقة :

A. هل هنالك اي مرجعيات (كودات، سياسات، قوانين، أنظمة، مواصفات ) موجهة لاستخدام أمثلا فعال) للطاقة في القطاع الزيوت في فلسطين ؟

B. ماهي أهم الممارسات الحكومية او المؤسساتية العاملة الحالية التي تعمل على توجيه قطاع الزيوت نحو استخدام امثل للطاقة؟(توظيف انظمة الطاقة المتجدده مثل الخلايا الشمسية ، شراء اجهزة توفير الطاقة ، تحفيز المباني الخضراء).

C. هل تملكون أي سياسات من اجل تخفيض الضرائب المفروضة على تطوير المشاريع الصديقة للبيئة وتحفيز برامج تطويرية للاستدامة المتعلقة بالاستخدام الامثل للطاقة ؟

D. هل هنالك اي مؤسسات توفر دعم مادي للمصانع التي تريد تطوير استهلاك الطاقة مثل مشاريع ممولة من الدول المانحة وهل هنالك الية لربطهم بهم؟

a. ما هي المرجعيات (كودات، سياسات، قوانين، أنظمة) الموجهة لاستخدام مستدام للمياه ترشيد الاستخدام (في القطاع الزيوت موجهة الى المصانع والمعاصر).

b. ما هي أهم الممارسات الحكومية الحالية او المستقبلية( التي تعمل على توجيه القطاع نحو استخدام امثل للمياه (اعادة تدوير المياه او أنظمة تجميع المياه).

### 3- النفايات الصلبة :

A. ما هي المرجعيات (كودات، سياسات، قوانين، أنظمة، مواصفات ) الموجهة لادارة النفايات الصلبة ومخلفات التصنيع .

B. ما هي أهم الممارسات الحكومية الحالية او المستقبلية التي تعمل على توجيه القطاع نحو استخدام مستدام للمواد الخام وادارة النفايات الصلبة(اعادة تدوير او استخدام مواد صديقة للبيئة او تقليل استخدام الأوعية او الأكياس البلاستيكية)

C. هل تملكون أي سياسات من اجل تخفيض الضرائب المفروضة على تطوير مشاريع صديقة للبيئة وتحفيز برامج تطويرية للاستدامة المتعلقة باعادة تدوير المواد او توفير ممول لتطوير تقنيات جديدة في التصنيع او اعفاءات ضريبية ؟

تقييم وجهات النظر والتحديات المتعلقة في الانتاج النظيف بقطاع الزيوت والسمنه النباتية في فلسطين

بروتوكول المقابلة – مصانع الزيوت والسمنه (تعبنة وتغليف ومعاصر الزيت)

المحور الاول : معلومات عامة

	اسم المؤسسة :
	اسم الشخص المقابل :
	المسمى الوظيفي :
	الخبره في المؤسسة :
	اليوم :
	الساعة :
	السوق الخاص في المنتجات
	عدد العاملين
	اخر تحديث لخط الانتاج

المحور الثاني : تقديم عن الدراسة

صباح الخير/ مساء الخير

بداية اود ان أشكركم على استجابتكم لتبليية دعوتنا في المقابلة.

واسمحوا لي بداية أن أقوم بالتعريف عن نفسي انا المهندس نشأت عثمان طالب دراسات عليا في برنامج مشترك

بين جامعة بيرزيت وجامعة النجاح برنامج هندسة الاستدامة في الانتاج وهذا الاستبيان هو لاستكمال متطلب

اطروحة تخرج في مجال تقييم مستوى الانتاج النظيف في صناعة الزيوت بفلسطين.

الهدف من الدراسة: تهدف هذه الدراسة إلى تقييم الوعي في مفهوم الانتاج النظيف في قطاع الزيوت بفلسطين من قبل الجهات الحكومية والاكاديمية والصناعة ، وتحديد أهم التحديات التي تواجه امكانية تطبيق الانتاج النظيف والفرص للتطوير القطاع المستهدف وفقا لوجهات النظر المختلفة من قبل الجهات المستهدفة في الدراسة.

ضمان السرية: سيتم التعامل مع هذه المعلومات بسرية تامة ولن يتم ذكر اسم المؤسسة او ما قد يدل عليها من قريب او بعيد.

المدة الزمنية للمقابلة: قد تستغرق هذه المقابلة ما مدته 20-40 دقيقة.

### المحور الثالث الأسئلة

هل توافق على تعريف الانتاج النظيف :

الانتاج الانظف :

هو تطبيق مستمر لاستراتيجية وقائية تشمل عمليات التصنيع والتسويق والخدمات، وتهدف الى زيادة الكفاءة والتقليل من الأخطار التي تلحق بصحة الانسان وبالبيئة.

(1) هل هنالك اي مواصفات فلسطينية قمت في تطبيقها تعنى في ترشيد استهلاك المياه، والطاقة وادارة النفايات الصلبة الخاصة في قطاع الزيوت في فلسطين للمصانع والمعاصر بشكل خاص.

(2) هل حصلت على احد المواصفات العالمية التالية شهادات الجودة العالمية ISO 14001 , ISO 2200 .

(3) هل هنالك اي برامج تدريبية تعنى في اعادة التدوير، التصنيع، ترشيد استهلاك المياه والطاقة في الشركة؟

4) كيف يتم نقل المنتج من مرحله الى اخرى خلال الانتاج؟

5) ما هي أبرز النشاطات ( ندوات، مؤتمرات، مشاريع، أبحاث، ورش عمل، المشاركة في وضع سياسات أو

مواصفات) التي قامت بها مؤسستكم أو مخطط أن تقوم بها فيما يتعلق بالاستخدام المستدام للطاقة، المياه،

المواد، البيئة والتلوث أو الاستثمار في التدريب للكوادر الموجودة بخصوص الموضوع أو الاستعانة

بشركات خارجيه؟

1- الطاقة :

A. هل هنالك اي مرجعيات (كودات، سياسات، قوانين، أنظمة، مواصفات ) لاستخدام أمثل\ فعال للطاقة في

مصنعكم؟

B. ما هي مصادر الطاقة لديكم؟

C. ما هي أهم المشاريع المنفذة خلال الخمس سنوات الاخيرة في مؤسستكم والتي تم فيها بالفعل مراعاة

الاستخدام

a. الامثل للطاقة؟

D. عند شراء الآلات هل يتم الأخذ بعين الاعتبار توفيرها للطاقة أو استخدامها لأحد مصادر الطاقة المتجددة ؟

E. ما هي اشكال الطاقة التي يتم استخدامها في مصنعكم بشكل محدد وما هو معدل الاستهلاك الشهري لها ؟

F. هل يوجد اي أنظمة رقابة يتم استخدامها في الانتاج لقياس كفاءة الطاقة؟

G. هل يتم تسخين المياه لديكم ؟ اذا نعم ما هو مصدر الطاقة المستخدمة وماهي كفاءته؟

H. هل يوجد نظام تبريد وتكيف في المنشأة ؟

I. هل يتم استخدام التيرموستات خلال العملية التصنيعيه؟

J. هل يوجد سياسة أو اجراء عمل خاص في ادارة الطاقة أو الترشيح في استخدامها؟

K. بخصوص المبنى الخاص بكم ما نوع العازل المستخدم؟ النوافذ والاضاءة؟

## 2- المياه

- a. هل هنالك اي مرجعيات (كودات، سياسات، قوانين، أنظمة، مواصفات ) لاستخدام أمثل\ فعال للطاقة في مصنعكم؟
- b. ما هو مصدر المياه لديكم؟ وهل لديكم بنر لجمع مياه الامطار؟
- c. هل هناك سياسات معينة لإعادة تدوير او استخدام المياه الناتجة عن العمليات الصناعية في مؤسستكم؟
- d. ما هي استخدامات المياه لديكم؟
- e. اين يتم التخلص من مياه الغسيل لديكم؟
- f. هل هنالك اي سياسات او اجراءات لترشيد استهلاك المياه لديكم؟
- g. ما هي نسبة اعادة استخدام المياه لديكم ( مصلح اعادة الاستخدام )
- h. ما هي نسبة اعادة تدوير المياه لديكم؟
- i. ما هو معدل استهلاك المياه الشهري لديكم؟ فاتروه المياة مثلا .
- j. هل هنالك اي طرق تستخدمك لجمع المياه خلال عملية الانتاج كل برك؟ وهل تعتبر صالحه لاعادة الاستخدام ام تحتاج الى معالجة؟ هل هنالك خطط للاستثمار بالموضوع؟
- i. هل هنالك اي داعي لمصدر يدمج بين التسخين المياه والكهرباء في الصنائه برايك؟

## 3- النفايات الصلبة:

- A. هل هنالك اي مرجعيات (كودات، سياسات، قوانين، أنظمة، مواصفات ) لاستخدام أمثل\ فعال للطاقة في مصنعكم؟
- B. ما هي المخرجات من عملية الانتاج لديكم تعتبر كنفائيات صلبة وهل هنالك اي Scrap يتم اعادة تصنيعه؟
- C. ما هي التقنيات المستخدمة لديكم لتقليل نسبة النفايات الصلب لديكم؟
- D. هل هناك اي اعتبارات يتم اخذها بخصوص شراء البكيج ان يكون من مواد صديقة للبيئة؟

E. هيل يتم تصميم البكيچ بطريقة مستدامة ؟ ما هي نوعية البكيچ لديكم؟

F. هل هنالك اي نفايات سامه او خطره على المستهلك؟

G. هل هنالك اي اجراءات عمل او برنامج خاص في ادارة النفايات الصلبة لديكم ؟

H. هلي تم بيع اي من المخرجات لديكم لتكون مدخل في صناعة اخرى؟

## بروتوكول المقابلة – القطاع الاكاديمي

## المحور الاول : معلومات عامة

	اسم المؤسسة :
	اسم الشخص المقابل :
	المسمى الوظيفي :
	الخبره في المؤسسة :
	اليوم :
	الساعة :
	عدد العمال
	آخر تحديث لخط الانتاج
	السوق الموجه

## المحور الثاني : تقديم عن الدراسة

صباح الخير/ مساء الخير

بداية اود ان أشكركم على استجابتكم لتبليية دعوتنا في المقابلة.

واسمحوا لي بداية أن أقوم بالتعريف عن نفسي انا المهندس نشأت عثمان طالب دراسات عليا في برنامج مشترك

بين جامعة بيرزيت وجامعة النجاح برنامج هندسة الاستدامة في الانتاج وهذا الاستبيان هو لاستكمال متطلب

اطروحة تخرج في مجال تقييم مستوى الانتاج النظيف في صناعة الزيوت بفلسطين.

الهدف من الدراسة: تهدف هذه الدراسة إلى تقييم الوعي في مفهوم الانتاج النظيف في قطاع الزيوت بفلسطين من قبل الجهات الحكومية والاكاديمية والصناعة ، وتحديد أهم التحديات التي تواجه امكانية تطبيق الانتاج النظيف والفرص للتطوير القطاع المستهدف وفقاً لوجهات النظر المختلفة من قبل الجهات المستهدفة في الدراسة.

ضمان السرية: سيتم التعامل مع هذه المعلومات بسرية تامة ولن يتم ذكر اسم المؤسسة او ما قد يدل عليها من قريب او بعيد.

المدة الزمنية للمقابلة: قد تستغرق هذه المقابلة ما مدته 20-40 دقيقة.

### المحور الثالث الأسئلة

هل توافق على تعريف الانتاج النظيف :

الانتاج الانظف :

هو تطبيق مستمر لاستراتيجية وقائية تشمل عمليات التصنيع والتسويق والخدمات، وتهدف الى زيادة الكفاءة والتقليل من الأخطار التي تلحق بصحة الانسان وبالبيئة.

A. هل يتم التطرق الى احد المواصفات التالية خلال المسابقات المطروحة في الخطط الدراسية ، ISO 2200 ، ISO 14001. وما هي التخصصات ؟

B. ما هي أبرز النشاطات ( ندوات، مؤتمرات، مشاريع، أبحاث، ورش عمل) التي تمت بخصوص الانتاج النظيف في قطاع الزيت النباتية والسمنه النباتيه؟

C. هل يتم توجيه الطلاب الى عمل مشاريع تخرج بخصوص الانتاج النظيف ؟

D. ما هي اهم المراكز التي تعنى في الطاقة، المياه ، البيئة في الجامعة؟

E. هل يوجد تعاون مشترك بين الجامعة وقطاع الزيوت بخصوص ايجاد حلول من طرف الجامعة مثل الاستعانة في مختبرات الجامعة عمل معايرة ايجاد حلول لبعض المشاكل في استهلاك الطاقة او المياه او النفايات الصلبة؟

1- الطاقة :

- A. هل هنالك اي مساقات يتم تدريسها بخصوص ادارة الطاقة في المصانع ؟
- B. هل يتم توجيه الطلبة لعلم مشاريع تخرج تعنى في مجال الانتاج النظيف؟
- C. برايك هل هنالك اي ابحاث تم نشرها بالخصوص؟
- D. ما هو دور المراكز المختصة لديكم في توجيه المصانع وتقديم اي حلول لزيادة كفاءة الطاقة المستخدمة في الانتاج؟
- E. هل يتم استخدام الموارد مثل المختبرات الخاصة بالجامعة من قبل المصانع؟

2- المياه

- A. هل هنالك اي تخصصات تعنى في ادارة المياه العادمة او الاستخدام الامثل لمصادر المياه؟
- B. هل يوجد اي دراسات تمت بخصوص استخدام المياه في صناعة الزيت النباتية والسمنة؟
- C. هل يتم توجيه الطلبة لعلم مشاريع بالخصوص؟
- D. هل يتم الاستعانة بمرافق الجامعة ( مختبرات، مراكز): لاجاد حلول لهذا القطاع؟

3- النفايات الصلبة :

- a. هل هنالك اي تخصصات تعنى في ادارة النفايات الصلبة ؟
- b. هل هنالك اي داراست تمت بخصوص ادارة النفايات الصلبة في قطاع الزيوت النباتيه؟

c. هل يتم توجيه الطلبة لعمل مشاريع تخرج بالخصوص؟

d. هل يتم الاستعانه بمرافق الجامعه ( مختبرات و مراكز بحث) لايجاد حلول وتطوير الصناعه في فلسطين؟

## Appendix III

### Cleaner production Options evaluation tool.

#### Technical option feasibility

Number	Criteria for Technical option total 30%	Weight	Options					
			Three-Phase Decanter		Two-Phase Decanter		Traditional pressing Mill	
			score	weighted score	score	weighted score	score	weighted score
1	Pomace/by-product quality.	3	3	9	1	3	2	6
2	Human resources and staff requirement.	-1	-1	1	-1	1	-3	3
3	Occupational health and safety.	-1	-1	1	-1	1	-3	3
4	Product specification ( color, taste, ph number).	3	2	6	3	9	1	3
5	Easy installation and implementation.	2	3	6	3	6	1	2
6	Time needs for implementation	-2	-1	2	-1	2	-3	6
7	social aspects	2	3	6	1	2	2	4
	<b>Total</b>			8		5		-3

#### Environmental evaluation tool

Number	Criteria for Environmental evaluation option total 35%	Weight	Options					
			Three-Phase decanter		Two phase Decanter		Traditional pressing mill	
			score	weighted score	score	weighted score	score	weighted score
1	The amount of wastewater (Ziber).	-3	3	-9	1	-3	2	-6
2	The amount in solid-waste generation	-2	2	-4	1	-2	2	-4
3	freshwater (used for washing and rinsing water).	-3	3	-9	1	-3	1	-3
4	The amount of energy used	-3	3	-9	2	-6	1	-3
5	The capability of adopting and utilizing rain water harvesting system	2	3	6	3	6	1	2
6	The capability of adopting and utilizing renewable energy, resources	2	3	6	3	6	1	2
7	water treatment opportunity	3	3	9	3	9	1	3
	<b>Total Score</b>			-10		7		-9



# تحري الطرق المثلى المتبعة في عمليات الانتاج النظيف في صناعة زيت الزيتون في فلسطين

إعداد

نشأت زياد العثمان

إشراف

أحمد أبو هنيه

عبدالرحيم أبو صفا

قدمت هذه الأطروحة استكمالاً لمتطلبات الحصول على درجة الماجستير في برنامج الهندسة  
المستدامة في الانتاج، بكلية الدراسات العليا، في جامعة بيرزيت وجامعة النجاح الوطنية ضمن  
البرنامج المشترك، نابلس - فلسطين.

2019

ب

تحري الطرق المثلى المتبعة في عمليات الانتاج النظيف في صناعة زيت الزيتون في فلسطين

إعداد

نشأت زياد العثمان

إشراف

أحمد أبو هنيه

عبدالرحيم أبو صفا

الملخص

تعد صناعة وعصر الزيتون من الصناعات والمواسم الهامة في فلسطين. تم دراسة وتحليل هذه العملية في مراحلها المختلفة واستنتاج الطرق المثلى التي يجب اتباعها في عملية الانتاج، عن طريق تطبيق تقنية الانتاج النظيف على قطاع زيت الزيتون في فلسطين.

تم جمع البيانات التي تخص القطاع والعملية الانتاجية بطريقة كمية واخرى نوعية؛ كمية من خلال استبيان خاص، ونوعية من خلال مقابلات معمقة مع ذوي العلاقة وشملت: اصحاب المعاصر والجهات الحكومية والوزارات المعنية وجهات أكاديمية، وبعد ذلك تم تحليل البيانات باستخدام ادوات تحليل مختلفة لاستنتاج الخيارات المثلى للإنتاج النظيف التي تخص صناعة زيت الزيتون.

وقد اثبتت نتائج تحليل الاستبيان والمقابلات والمشاهدات العينية وجود اثراً سلبياً مباشراً لمخلفات عصر زيت الزيتون خاصة المخرجات من الزيبار الذي يعمل على تلويث الاراضي الزراعية والمياه الجوفية.

تم اقتراح طرق مثلى جديدة لاتباع في العمليات الانتاجية من قبل اصحاب المعاصر لتخفيف الضرر البيئي من مخلفات الزيتون وتقليل استهلاك الموارد واستخدامها بشكل اكثر نجاعة.

وشمل نطاق البحث تحليلاً لمجمل العملية الانتاجية ابتداء من مرحلة الحصاد، وصولاً الى مرحلة المستهلك، والتخلص من الفاقد خلال العمليات الانتاجية.

كما شملت الدراسة اجراء مقارنة ما بين انواع المعاصر المستخدمة في فلسطين وقياس اثرها على البيئة، وتبين بان المعاصر الحديثة التي تستخدم الطرد المركزي Three-phase هي الاكثر انتشارا في فلسطين لأنها تحتاج لأيد عاملة اقل، وانتاجية اعلى من الزيت قياسا بالمعاصر القديمة، لكن اشكالية هذا النوع من المعاصر انه لا يراعي الموضوع البيئي ويأخذه بعين الاعتبار. اما المعاصر الحديثة التي تستخدم الطرد المركزي Two-phase فهي نادرة في فلسطين حيث تم حصر معصرة واحدة فقط، وهذا النوع غير مفضل لدى اصحاب المعاصر لان مخرجات العملية الانتاجية تحتاج الى معالجة وهو ما يترتب عليه نقل وتكلفة اعلى من غيرها، اما من حيث التأثير البيئي فهي الافضل من بين الانواع الاخرى.

