



An-Najah National University

Faculty of Engineering and Information Technology

Energy and Environment Engineering Department

Graduation Project: (10656598)

Optimum Design of a Stand-Alone/ON-Grid Hybrid Energy  
System of Wastewater Treatment Plant (WWTP) in Anza  
Village

Submitted to: Dr. Aysar Yassin

Prepared by:

Nour Abdelrahim (11526929)

2020/2021

Presented in partial fulfillment of the requirements for Bachelor degree in  
(Energy and Environment Engineering).

## Dedication

I dedicate my final graduation project to my God who did not LEAVE me ALONE through my studying period AND help me to overcome ALL difficulties THAT happened to prevent me to be. I AM here because of its mercy, its satisfaction, its forgiveness AND its love. My God the only one who deserve to THANK.

## Acknowledgment

I would like to express my deepest gratitude to my graduation project supervisor Dr. AYSAR YASSIN for his patience AND guidance. In ADDITION, it is my duty to THANK ALL the educational staff members of the chemical AND environment AND energy engineering DEPARTMENT represented by:

Dr. Mhommmed ASAYED, Dr. AbdelRAHIM Abu-ASAFA, Dr. AMJAD AL-QANNI AND Dr. TAMIR AL-KHATIB.

Also, I would THANK Dr. MOEAN OMAR AS he one of the testing committee members.

At last, I would like to THANK Mr. OSAMA ALoumor (Abu-Hadi) for his effort in providing me with all information about the WASTEWATER TREATMENT PLANT.

**Abstract:**

Hybrid energy system is a good solution to overcome the difficulties and the problems which were faced when dealing with single renewable energy sources such as photovoltaic energy conversion system (PVECS) and Wind Energy Conversion System (WECS). By using Hybrid Optimization Model for Electric Renewable (HOMER) pro software, the process has been solved completely.

The (WWTP) comprises Water Motor of 0.75kW, Reuse Pump of 1.1kW, Skimmer of 0.75kW, Blower of 11kW, Sludge Pump of 1.1kW, Ras Pump of 3kW, 2 mixers of 6kW, Drive Drum of 0.55kW, Drive Blower of 0.65kW, Drive Screen Plant of 1.1kW, Drive Horizontal screw of 0.55kW, Drive Vertical Screw of 1.1kW and Submersible Pump of 1.3kW.

The region has abundant solar radiation potential with a daily average 5.19kWh/m<sup>2</sup> and average wind speed 5.43m/s. The design of the standalone hybrid system of the Waste Water Treatment Plant (WWTP) with Photovoltaic Energy Conversion System (PVECS), Wind Energy Conversion System (WECS) and Battery Energy Storage System (BESS) and the design of the on-grid hybrid system were been performed and the obtained optimum design of the off-grid was the PVECS, WECS and BESS with DG. The Cost of Energy (COE) is \$0.141 and the net present cost of the system (NPC) is \$150,882. The SPP is 6 year. The obtained optimum design of the on-grid was the PVECS, WECS and Grid connected with DG. The Cost of Energy (COE) is \$0.0495 and the net present cost of the system (NPC) is \$135,572. The SPP is 3 year. The most economic one between the two scenarios: is the on-grid.

## **Table of Contents (TOC):**

Abstract: .....	4
Table of Contents (TOC): .....	5
List of Figures (LOF): .....	6
Nomenclature: .....	8
Chapter 1: Introduction. ....	10
Chapter 2: Introduction to the used programs.....	12
Chapter 3: Literature review.....	13
Chapter 4: Calculations.....	14
Chapter 5: Site description and load demand. ....	15
Chapter 6: Hybrid energy sources.....	15
Chapter 7: Results and Discussion. ....	20
Chapter 8: Conclusion. ....	50
References: .....	51

## List of Figures (LOF):

Figure 1: Schematic of the proposed stand-alone hybrid system .....	2
Figure 2: Schematic diagram of the on-grid hybrid system .....	2
Figure 3: Daily load profile.....	6
Figure 4: Average daily solar radiation .....	7
Figure 5: Average wind speed .....	7
Figure 6: Hybrid pro schematic diagram of off-grid system.....	8
Figure 7: Hybrid pro schematic diagram of on-grid.....	8
Figure 8: Wind turbine power profile.....	9
Figure 9: Diesel generator efficiency curve in off-grid system. ....	10
Figure 10: Diesel generator efficiency curve in on-grid system .....	10
Figure 11: Simulation results of the off- grid hybrid configuration system.....	11
Figure 12: Simulation results of the on- grid hybrid configuration system .....	11
Figure 13: Monthly average electric production of the hybrid system .....	12
Figure 14: The net present value categorizing by hybrid system components.....	13
Figure 15: The detailed NPC costs of the hybrid system.....	14
Figure 16: The annualized cost of each component of the hybrid system .....	14
Figure 17: The detailed annualized costs of the hybrid system.....	15
Figure 18: Monthly average electric production of the hybrid system .....	16
Figure 19: The net present value categorizing by hybrid system components.....	17
Figure 20: The detailed NPC costs of the hybrid system.....	17
Figure 21: The annualized cost of the hybrid system components. ....	18
Figure 22: The detailed annualized cost of each component of the hybrid system .....	18
Figure 23: Monthly average electric production of the hybrid system .....	19
Figure 24: The net present value categorizing by hybrid system components.....	20
Figure 25: The detailed NPC costs of each component in the system.....	21
Figure 26: The annualized cost of each component of the hybrid system .....	21
Figure 27: The detailed annualized cost of each component of the hybrid system .....	22
Figure 28: Monthly average electric production of the hybrid system .....	23
Figure 29: The net present value categorizing by hybrid system components.....	24
Figure 30: The detailed NPC costs of each component in the system.....	24
Figure 31: The annualized cost of each component of the hybrid system .....	25
Figure 32: The detailed annualized cost of each component of the hybrid system .....	25
Figure 33: Monthly average electric production of the hybrid system .....	26
Figure 34: The net present value categorizing by hybrid system components.....	27
Figure 35: The detailed NPC costs of each component in the system.....	28
Figure 36: The annualized cost of each component of the hybrid system .....	28
Figure 37: The detailed annualized cost of each component of the hybrid system .....	29
Figure 38: Monthly average electric production of the hybrid system .....	30
Figure 39: The net present value categorizing by hybrid system components.....	31
Figure 40: The detailed NPC costs of each component in the system.....	31
Figure 41: The annualized cost of each component of the hybrid system .....	32
Figure 42: The detailed annualized cost of each component of the hybrid system .....	32
Figure 43: Monthly average electric production of the hybrid system .....	33

Figure 44: The net present value categorizing by hybrid system components..... 34

Figure 45: The detailed NPC costs of each component in the system..... 34

Figure 46: The annualized cost of each component of the hybrid system ..... 35

Figure 47: The detailed annualized cost of each component of the hybrid system ..... 35

Figure 48: Monthly average electric production of the hybrid system ..... 36

Figure 49: The net present value categorizing by hybrid system components..... 37

Figure 50: The detailed NPC costs of each component in the system..... 37

Figure 51: The annualized cost of each component of the hybrid system ..... 38

Figure 52: The detailed annualized cost of each component of the hybrid system ..... 38

## **Nomenclature:**

Photovoltaic Energy Conversion System (PVECS).

Wind Energy Conversion System (WECS).

Wastewater Treatment Plant (WWTP).

Hybrid Optimization Model for Electric Renewable (HOMER).

Electrical Transient Analyzer Program (ETAP).

Israeli Electrical Company (IEC).

Average (avg).

Kilovolt (kV).

Energy Storage System (ESS).

Diesel Generator (DG).

Renewable Energy Sources (RES).

Megawatt (MW).

Kilowatt hour per meter square (kWh/m<sup>2</sup>).

Kilowatt per hour (kW/h).

Figure (Fig).

Battery Energy Storage System (BESS).

Meter (m).

Operating and Maintenance Cost (O&M).

Cost of Energy (COE).

Net Present Cost (NPC).

Capacity Factor (CF).

Year (yr).

Hours (hrs).

Liter (L).

Kilogram/year (kg/yr).

Present worth (Pw).

Annual worth (Aw).

Return on Investment (ROR).

Internal Rate of Return (i).

Simple Payback Period (SPP).

Discounted Payback Period (DPP).

Maximum Annual Capacity Shortage (MACS).

## **Chapter 1: Introduction.**

Palestinian Territories face a severe shortage of energy supply as well as the fluctuations of energy prices. The Palestinian authority has no control on borders, so all energy products are bought from Israeli companies. Small fraction of electrical energy demand is locally generated in Gaza power plant and about 37 megawatts (MW) is imported from Jordan and Egypt.

The electrical energy in Palestinian territories represents about 31% of total energy consumed. The available electrical energy is insufficient to cover the demands of the local market especially the growth in electricity consumption reaches about 7%. High electrical tariff rates are imposed from the Israeli Electrical Company (IEC) compared with the neighboring countries (Milhem, 2020).

The alternative solution for some facilities and residential buildings is to use small diesel generators, which it is not an economic and environmental solution because of the high prices of diesel and the high number of bad emissions that released.

Another solution is to use the renewable energy sources individually, that means to install single Photovoltaic Energy Conversion System (PVECS), since Palestine country has a high solar radiation and the horizontal yearly average daily solar radiation about 5.6-kilowatt hour per meter square (kWh/m<sup>2</sup>) with about 3000 sunshine hours (Yasin, 2017) . Or Wind Energy Conversion System (WECS) with low possibility, since the average (avg) wind speed not enough to generate power. In addition, the interruption in the previous renewable sources due to seasonal and daily weather variations as well as the stochastic nature of wind energy makes it unreliable choice.

So, this directs the views to find an economic, reliable and environmental solution to cover the electricity demand for any facility. With the development in renewable energy world, the hybrid renewable energy system is a good choice to cover the electricity demand by a combination of more than one source such as, Diesel Generator (DG) and Battery Energy Storage System (BESS) with PVECS and WECS maybe stand-alone or grid connected. The hybrid system is more reliable and economic choice.

In this project, tow hybrid energy systems consist of PVECS, WECS and BESS with DG and PVECS, WECS and Grid with DG are proposed to apply to cover the electrical demand of the Wastewater Treatment Plant (WWTP) in Anza village, in Jenin city.

Figure.1 shows a schematic diagram of the considered stand-alone hybrid system.

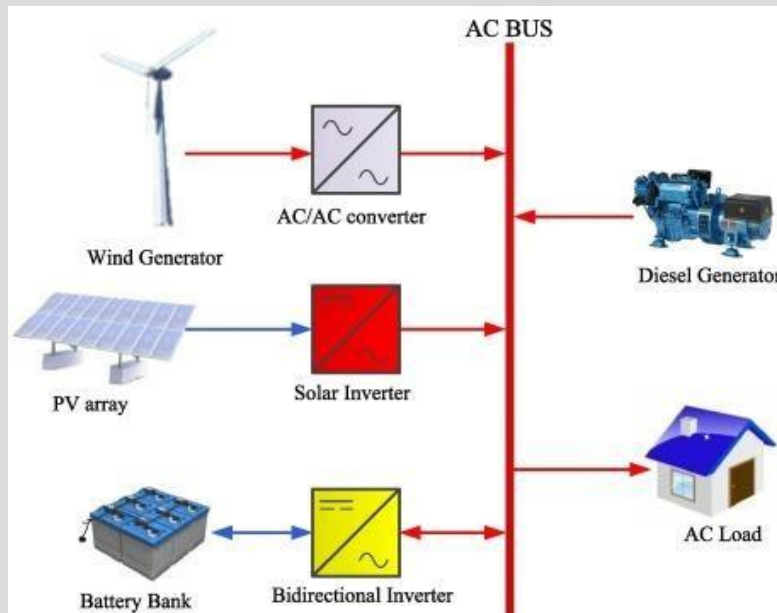

Figure 1: Schematic of the proposed stand-alone hybrid system

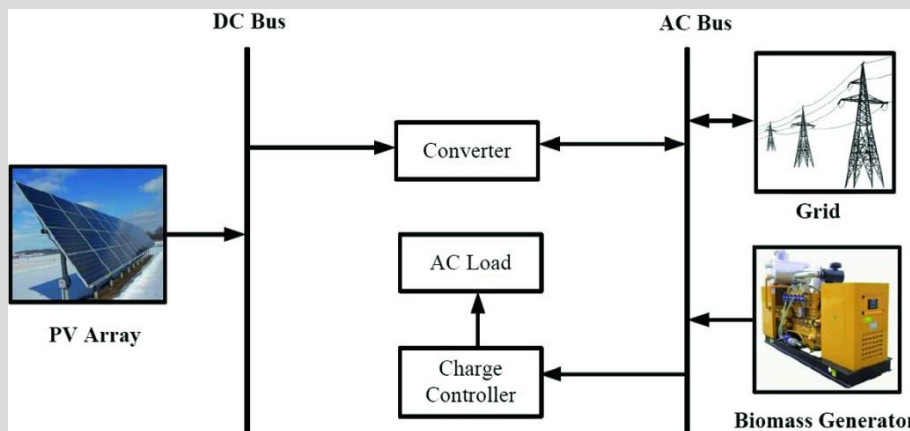

Figure 2: Schematic diagram of the on-grid hybrid system.

The analysis of such these systems has a complexity since they deal with variables and non-linear relations between the parameters related to each component. Hybrid Optimization Model for Electric Renewable (HOMER) pro software developed to deal with these systems.

The report includes a simple view about HOMER pro software, description of the site and of the components of the system, the design of the system, the simulation and optimization results and a conclusion which will summarize the results.

## **Chapter 2: Introduction to the used programs.**

### **Homer Pro Software.**

The design and analysis of micro-power are not easy work due to having large number of design choices as well as the demand to study the effect of changing different parameters. The intermittent nature of renewable energies adds further complexity to the analysis and design. HOMER pro software came to cope with such complex jobs.

HOMER is a tool for rapid assessment of least cost solutions for clean and reliable power. This software application is used to design and evaluate technically and financially the options for off-grid and on-grid power systems for remote, stand-alone and distributed generation applications through performing three primary tasks: simulation, optimization, and sensitivity and is simplifies the mission of finding the optimum design of the power system. It allows you to consider a large number of technology options to account for energy resource availability and other variables.

**Simulation:** At its core, Homer is simulation model. It will attempt to simulate a viable system for all possible combinations of the equipment that you wish to consider. Depending on how you set up your problem, Homer may simulate hundreds or even thousands of systems. Homer simulates the operation of a hybrid micro grid for an entire year, in time steps from one minute to one hour.

**Optimization:** Homer examines all possible combinations of system types in a single run, and then sorts the system according to the optimization variable of choice. Homer pro features our new optimization algorithm that significantly simplifies the design process for identifying least-cost options for micro grids or other distributed generations electrical power systems. Homer Optimizer is a proprietary “derivative free” optimization algorithm that was designed specifically to work on Homer.

**Sensitivity analysis:** Homer lets you ask as many “What if?” questions as you would like, because you cannot control all aspects of a system, and you cannot know the importance of a particular variable or option without running hundreds or thousands of simulations and comparing the results. Homer makes it easy to compare thousands of possibilities in a single run. This allows you to see the impact of variables that are beyond your control, such as wind speed, fuel costs, etc. And understand how the optimal system changes with these variations (Okinawa Enetech Co, 2016).

### **Chapter 3: Literature review.**

<sup>1</sup>Proposed using a stand-alone hybrid energy system based mainly on renewable energy sources and diesel generator. To deal with such complicated systems since it is hybrid, the HOMER pro software was the choice. The optimum design based on HOMER requires incident solar radiation data, wind speed data, electrical demand profile, fuel cost, equipment characteristics and costs. The optimum results showed that the best one which consists of Photovoltaic Energy Conversion System (PVECS), Wind Energy Conversion System (WECS), Battery Energy Storage System (BESS) and Diesel Generator (DG), which is the dependable to use to electrify a small village in Palestinian territories.

<sup>2</sup>This study focuses on the stand-alone PV-Wind hybrid renewable energy systems. It also presents different sizing techniques for off-grid PV-Wind hybrid renewable energy systems accurate sizing of hybrid renewable energy systems can significantly help to determine the initial capital investment while maintaining system reliability at minimum cost. It demonstrates that the hybrid energy system can significantly reduce the total life cost of stand-alone power supplies in many situations, while at the same time providing a more reliable supply for electricity through a combination of energy sources.

<sup>3</sup>It makes an economic study on some hybrid renewable energy systems with and without grid connected, the result shows that the most economic one, which has PV/Wind turbine with grid connected.

<sup>4</sup>This paper is aimed at combining WECS, PVECS and fuel cells (FC) generating systems to maximize the output energy and reduce the output power fluctuations for stand-alone applications. The proposed hybrid energy WECS, PVECS and FC system is connected to the grid through a PWM inverter as a distributed generation system to relieve the demand tension of electricity on the grid and act as an uninterruptible power source when the grid is disconnected.

<sup>5</sup>This study presented an optimal hybrid renewable off-grid energy system model that supplies a healthcare center. A technical and economic evaluation was carried out to identify the optimal off-grid hybrid energy system combination based on PV, WCES, DG and BESS.

---

<sup>1</sup> (Yasin, 2017)

<sup>2</sup> (Ahmed H. A., 2016)

<sup>3</sup> (Moniure, 2012)

<sup>4</sup> (Ahmed N. A., 2012)

<sup>5</sup> (Engineering E. S., 2019)

## Chapter 4: Calculations.

### PV calculations:

The monthly consumption is about 5550 kWh/month.

$5550 \text{ (kWh/month)} / (30\text{day/month}) = 185\text{Wh/day}$ , daily consumption of the plant.

Note: 185kWh/day can be varied from month to another.

From the output homer data the annual average of solar irradiance is 5.19kWh/kW/day.

The rated capacity power of the PV system  $185\text{Wh/day} / 5.19\text{kWh/kW/day} = 36\text{kW}$ .

The rated capacity of each panel = 0.325kW.

- Proposed # of the panels =  $36\text{kW}/0.325\text{kW}=110$  panel.

### Inverter:

The power of inverter equals to the power of the PV system.

P of the inverters = 36kW.

The power of the proposed inverter equals to 5kW.

- Proposed # of inverters =  $36\text{kW}/5\text{kW} = 7$ inverters.
- Proposed configuration of the panels on each inverter:

$110 \text{ panel}/7\text{inverters} = 16 \text{ panel/inverter}$ .

### Batteries:

Nominal voltage of the proposed batteries = 12V.

Voltage of the system = 48V.

Ampere hour of the battery = 232Ah.

Ampere hour of the wanted battery = watt-hour of the load (kWh)/ voltage of the system.  
 $= 185/48= 3.854 *1000 = 3854\text{Ah}$ .

- Proposed # of strings =  $3854\text{Ah}/232\text{Ah}= 16$  strings.
- Proposed # of strings on each inverter =  $16\text{strings}/7\text{invertes} = 2$  string.
- Proposed # of batteries in series in each string = voltage of the system/voltage of the battery =  $48/12 = 4$  batteries.
- # of batteries on each inverter are 8 batteries.

**So**, the proposed configuration: 7 inverters, 16 panel on each inverter, 2 strings of batteries on each inverter and each string has 4 batteries.

## Chapter 5: Site description and load demand.

The WWTP in Anza village which is located in the south of Jenin governorate which at coordinates 35.29° N, 32.2164° E. The main job of it is to treat the wastewater and the output products from, the sludge, which can be treated and then can be used as a fertilizer or to produce biogas and the produced water can be used for crops irrigation specially olives and almonds or retrieve it to the WWTP.

The electrical loads in the WWTP are Water Motor of 0.75kW, Reuse Pump of 1.1kW, Skimmer of 0.75kW, blower of 11kW, Sludge Pump of 1.1kW, Ras Pump of 3kW, 2 mixers of 6kW, Drive Drum of 0.55kW, Drive Blower of 0.65kW, Drive Screen Plant of 1.1kW, Drive Horizontal screw of 0.55kW, Drive Vertical Screw of 1.1kW and Submersible Pump of 1.3kW.

The load profile is derived based on the electrical loads in the WWTP by the software. The average energy demand is 185kWh/day. The average and high daily power demand is observed to be 7.71 kW and 20.42kW, respectively. The average load factor 0.38.

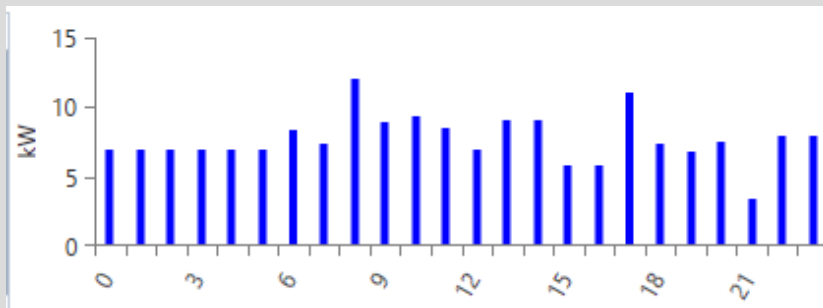

Figure 3: Daily load profile.

## Chapter 6: Hybrid energy sources.

### a. Solar radiations profile.

Palestinian territories have sufficient solar radiation potential to utilize solar electricity specially the photovoltaic energy since the daily average of solar radiation on horizontal surface was measured to be 5.19kWh/m<sup>2</sup>.day ((ERC), 2020). Fig.3 shows the monthly average daily solar radiation input data of the selected site to HOMER software, which in role generates synthetic 8760-hour total solar radiation data set utilizing procedure established by Graham and Hollands (Hollands, 1999)

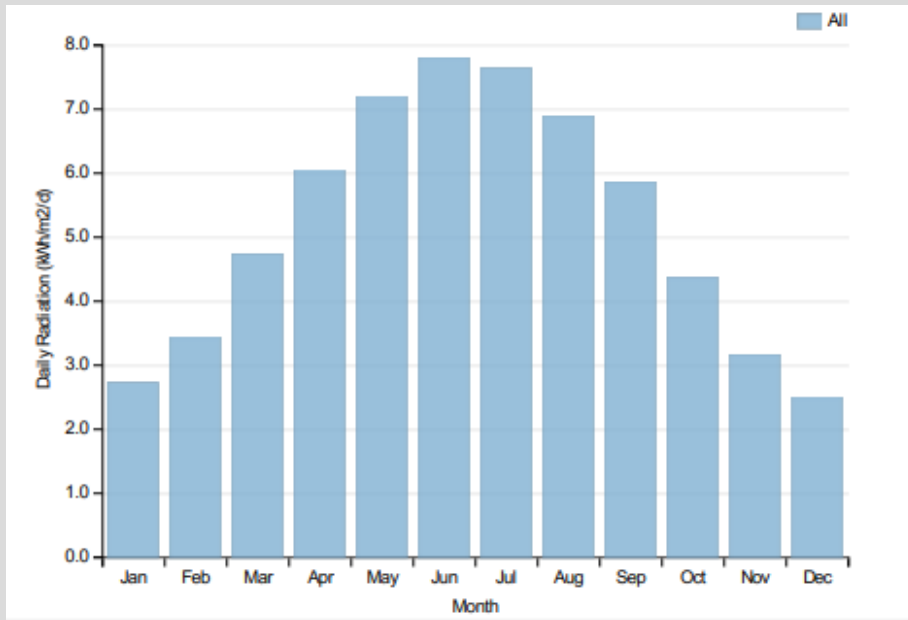

Figure 4: Average daily solar radiation.

b. Wind speed profile.

The potential of wind energy in Palestinian is generally limited (Shawon MJ, 2013)but, in some locations the average wind speed may reach 4-5m/s which is sufficient for small scale wind turbines.

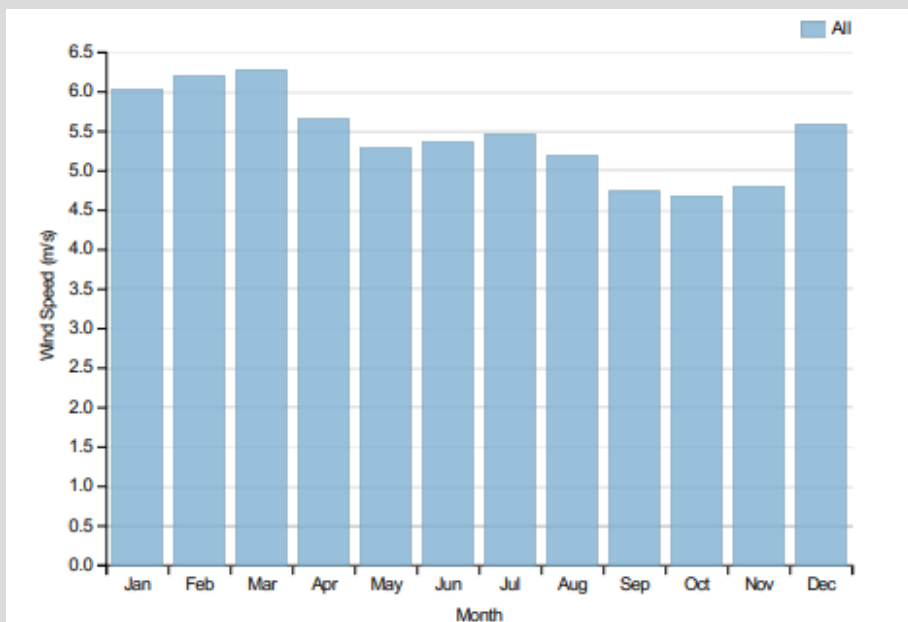

Figure 5: Average wind speed.

c. Diesel fuel.

The physical properties of the fuel used which is for diesel fuel: density of 820kg/m<sup>3</sup>, lower heating value 43.2 MJ/kg, carbon content 88% and sulfur content 0.4%. The average price of the diesel fuel in Palestinian territories is about 1.31\$/L of this year (2020).

d. Grid.

The source of the electricity in Palestine is the IEC with 0.17\$/kWh of feed tariff and the grid sell price is zero. The total imposed power is about 1235MW.

### Configuration of Hybrid Energy System.

The proposed off-grid and on-grid configurations of Hybrid Energy System and consisting of PVECS, WECS, DG, BESS and Grid. The analysis of such a complicated system is based on HOMER pro software. The HOMER pro schematic diagram of the hybrid systems is shown in Fig.6.

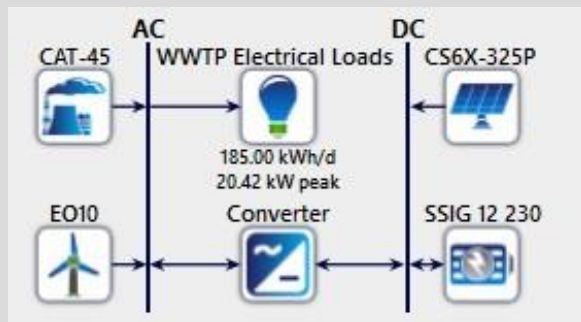

Figure 6: Hybrid pro schematic diagram of off-grid system.

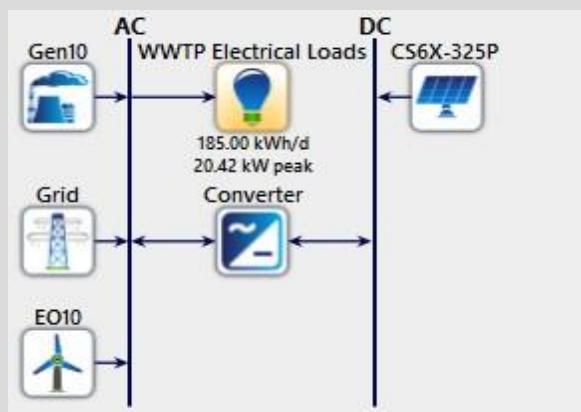

Figure 7: Hybrid pro schematic diagram of on-grid.

The technical specification and cost of each component used in the software is illustrated in details. The price of each component based on the local prices in Palestinian territories on 2020. The lifetime of the project is 25years.

a. Photovoltaic Energy Conversion System (PVECS).

The proposed PV panels from Canadian Solar manufacture company labeled as CS6X-325P, the main data needed for PVECS includes: the size of PVECS, the capital, replacement and O&M costs are 36kW,25340\$, 0\$ and 10\$/year, respectively. The lifetime of the PVECS is 25years. The de-rating factor is 90% and the system is fixed without tracking at a slope of 28°angle and 0°azimuth angle. The temperature coefficient is  $-0.41\%/^{\circ}\text{C}$ , operating temperature of 45 °C and efficiency of 16.94%.

b. Wind Energy Conversion System (WECS).

Selecting the appropriate WECS is not an easy mission as it is essential that the characteristics of the turbine and the wind regime at which it works should be properly matched. The capacity factor of the system can be useful indication for the effective matching of wind turbine and regime. The proposed wind turbine in the system from Eocycle manufacture labeled as EO10.The rated power of the selected wind turbine is 10kW with rotor diameter of 15.8m, 5m height, cut-in speed of 2.75m/s and cut-out speed of 20m/s.

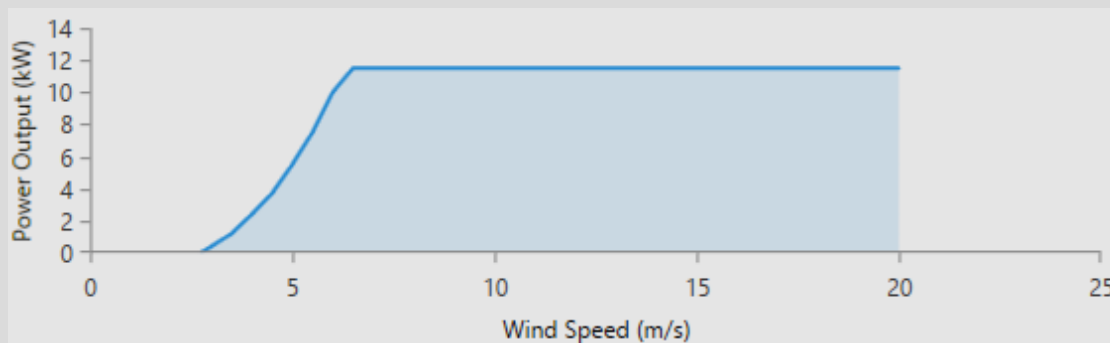

Figure 8: Wind turbine power profile.

The capital, replacement, and O&M costs are 7000\$, 0\$ and 35\$/year, respectively. The lifetime is 20 years.

c. Power Converter.

The converter can work as an inverter once converts electric power from DC to AC and the efficiency is assumed 95%, and at the same time it can work as a rectifier once converts the electric power from AC to DC and the efficiency is assumed 95%. The capital, replacement and O&M costs are 2716.4\$, 0\$ and 15\$, respectively. The lifetime is 15years.

#### d. Diesel Generator (DG).

Diesel generator is used as dispatch-able energy at this to compensate power in the lack of renewable energy source. The proposed DG in off-grid system is CAT-45kW-60Hz-PP of 45kW capacity. The capital, replacement and O&M costs are 2285\$, 0\$ and 10 \$/year, respectively. The lifetime of the diesel generator is 15000 operating hours.

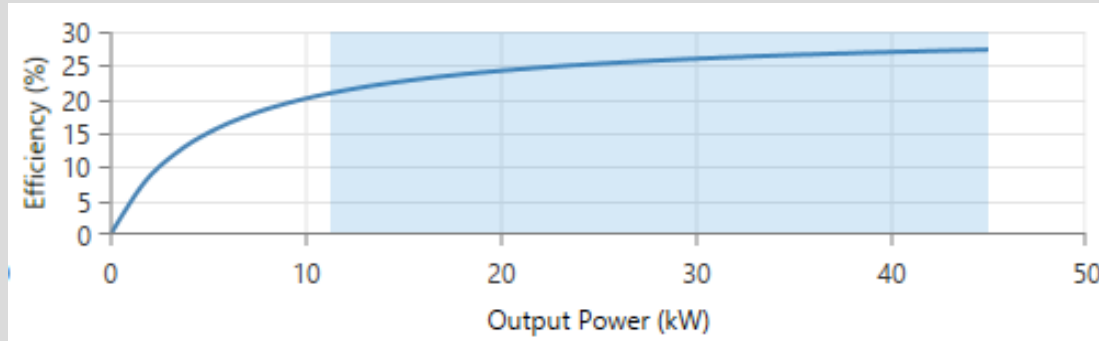

Figure 9: Diesel generator efficiency curve in off-grid system.

The proposed DG in on-grid system is CAT-10kW Fixed Capacity Genset of 10kW capacity. The capital, replacement and O&M costs are 2500\$, 0\$ and 30 \$/year, respectively. The lifetime of the diesel generator is 15000 operating hours.

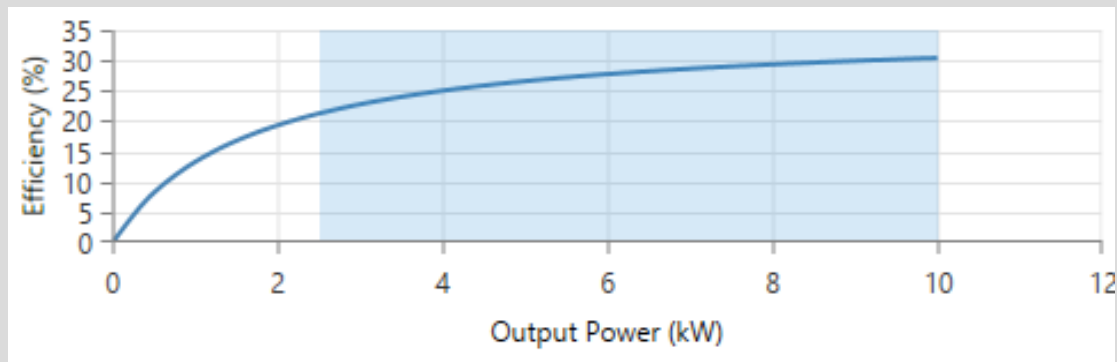

Figure 10: Diesel generator efficiency curve in on-grid system.

#### e. Battery Energy Storage System (BESS).

The BESS is very important in a stand-alone system as renewable energy sources are intermittent and stochastic in nature. The physical properties of the battery bank used in the study (Trojan SSIG 12 230) are: the nominal voltage 12V, nominal capacity 232Ah (2.78kWh), round-trip efficiency 80%, and minimum state of charge 40%. The capital, replacement and O&M costs are 19600\$, 0\$ and 15\$/year, respectively. The lifetime 5yrs. The proposed batteries configuration, distributed as 2 strings each one has 4 series batteries of 12 nominal volt of each one, so the output voltage is 48V on each inverter. The proposed No. of batteries 56.

f. Grid.

The grid power price is 0.17\$/kWh, and the grid sell price is zero. The net metering system did not be used in the project.

## Chapter 7: Results and Discussion.

### The Optimization Results of the Hybrid Systems.

HOMER pro software shows optimization results by revealing only the least-cost configuration within each system category, which means that the software suggests different type of schemes with different energy systems. After performing great number of simulations, the most feasible configurations are shown below:

Architecture										Cost				System	
					CS6X-325P (kW)	EO10	CAT-45 (kW)	SSIG 12 230	Converter (kW)	Dispatch	COE (\$)	NPC (\$)	Operating cost (\$)	Initial capital (\$)	Ren Frac (%)
					33.8	4	45.0	124	21.3	LF	\$0.141	\$150,882	\$557.03	\$142,037	99.6
						9	45.0	232	46.6	LF	\$0.198	\$212,058	\$2,306	\$175,441	98.0
					89.2		45.0	180	22.5	LF	\$0.200	\$214,538	\$1,754	\$186,693	98.4
					164	30	45.0		24.4	CC	\$0.932	\$999,843	\$45,220	\$281,783	56.7

Figure 11: Simulation results of the off- grid hybrid configuration system.

Architecture										Cost				System	
					CS6X-325P (kW)	EO10	Gen10 (kW)	Grid (kW)	Converter (kW)	Dispatch	COE (\$)	NPC (\$)	Operating cost (\$)	Initial capital (\$)	Ren Frac (%)
					16.3	4	10.0	999,999	10.8	CC	\$0.0495	\$135,572	\$4,360	\$66,340	87.8
						5	10.0	999,999		CC	\$0.0506	\$148,189	\$5,708	\$57,556	85.0
					29.1		10.0	999,999	14.9	CC	\$0.148	\$189,003	\$8,021	\$61,634	50.9
							10.0	999,999		CC	\$0.239	\$255,939	\$13,595	\$40,056	0

Figure 12: Simulation results of the on- grid hybrid configuration system.

## STAND-ALONE HYBRID SYSTEM.

### Configuration 1: PVESC/WECS/BESS with DG.

The optimization analysis shows that the hybrid system considered of PVESC/WECS/BESS with DG is the most economic hybrid system. It includes PVESC with 33.8kW, 4WECSs, 124 batteries, 45kW DG and 21.3kW converter capacity.

The total capital cost of the optimum hybrid system includes the capital cost, replacement cost and O&M cost and salvage cost is about \$150,882, which is the Net Present Cost (NPC) of the system. The Cost of Energy (COE) produced by this configuration is \$0.141.

The total electricity production of the system 184,938kWh/yr and the renewable energy fraction 99.6%.

The monthly average electric production of the hybrid system components is illustrated in Fig.13.

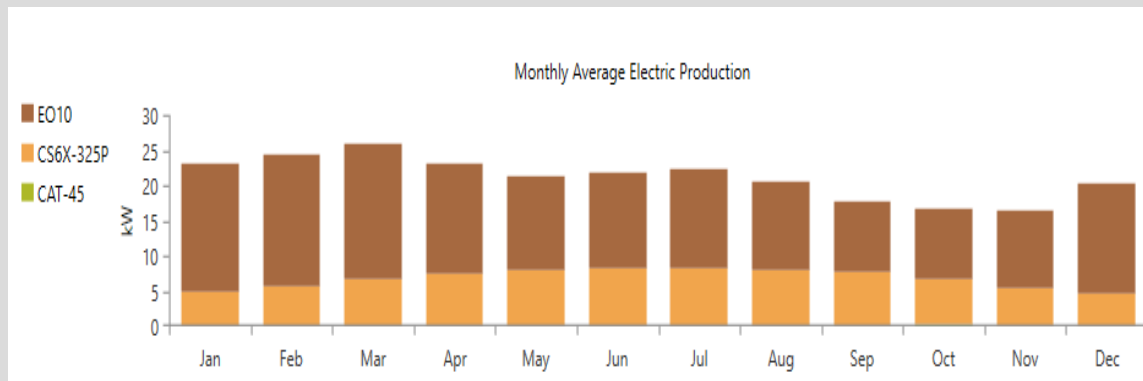

Figure 13: Monthly average electric production of the hybrid system.

The annual AC primary load is 67,526kWh/yr and the annual excess electricity production 110,574kWh/yr is about 59.8% from the total annual energy produced.

The total energy production annually from PVECS is 59,188kWh, which is about 32% from the total annual energy produced, and 87.7% from the AC primary load (PV penetration). The number of operational hours is 4368hrs/yr and the capacity factor (CF) is 20%. The mean output per day is 162kWh/day and the COE of energy from PVECS system 0.0255\$/kWh.

The total energy production annually from WECS is 125,503 kWh, which is about 67.9% from the total annual energy produced, and 168% from the AC primary load (wind penetration). The number of operational hours is 5956hrs/yr and the CF is 35.8%. The mean output is 14.3 kW and the COE of energy from WECS system 0.00758\$/kWh.

For the system converter, the capacity of the inverter 21.3kW, the mean output 3.29kW, the max output 18.5kW, the CF 15.4%, the hours of operation 4520hrs/yr, the output energy 28,829kWh/yr and the input energy 30,346kWh/yr. The capacity of the rectifier 21.3kW, the mean output 0.957kW, the max output 21.3kW, the CF 4.49%, the hours of operation 2323hrs/yr, the output energy 8380kWh/yr and the input energy 8821kWh/yr.

For the batteries system, No. of batteries is 124, string size 4battries, 31string, the bus voltage 48V, the autonomy is 26.9hr, the nominal capacity is 345kWh, usable nominal capacity 207kWh, lifetime throughput 207,080kWh and the expected life 9.41yr. The input energy is 24,559kWh/yr, the output energy 19,679kWh/yr, storage depletion of 35.2kWh/yr and the annual throughput 22001kWh/yr.

The electrical production annually from diesel generator is 248kWh/yr, which is about 0.134% from the total annual energy produced. The annual operational hours 22hrs/yr and the CF is about 0.0628%. The fixed generation cost is US\$12.2/h; the specific diesel consumption is 0.486L/kWh while the annual diesel consumption is 120L. The electrical efficiency 20.8% and the operational life 68.2yr.

The average (avg) fuel per day is 0.329L/day and the avg fuel per hour is 0.0137L/hr

The values of emitted emissions of carbon dioxide, carbon monoxide, unburned hydrocarbons, particulate matter, sulfur dioxide and nitrogen oxides are 318kg/yr, 0, 0, 0, 0.789kg/yr and 0, respectively.

The NPC categorized by hybrid system component is shown in Fig.14, which shows that the BESS has the highest NPC while the Converter has the lowest.

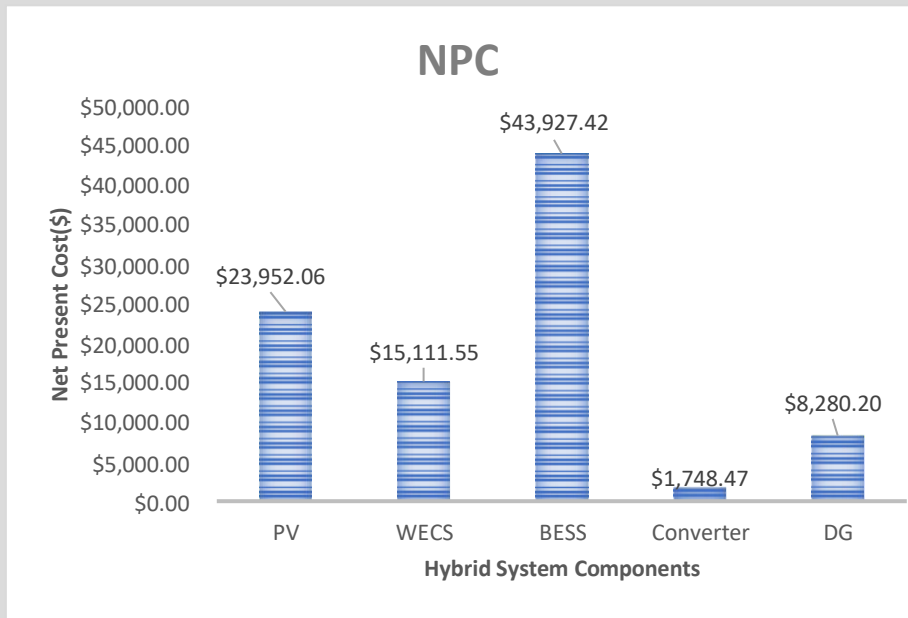

Figure 14: The net present value categorizing by hybrid system components.

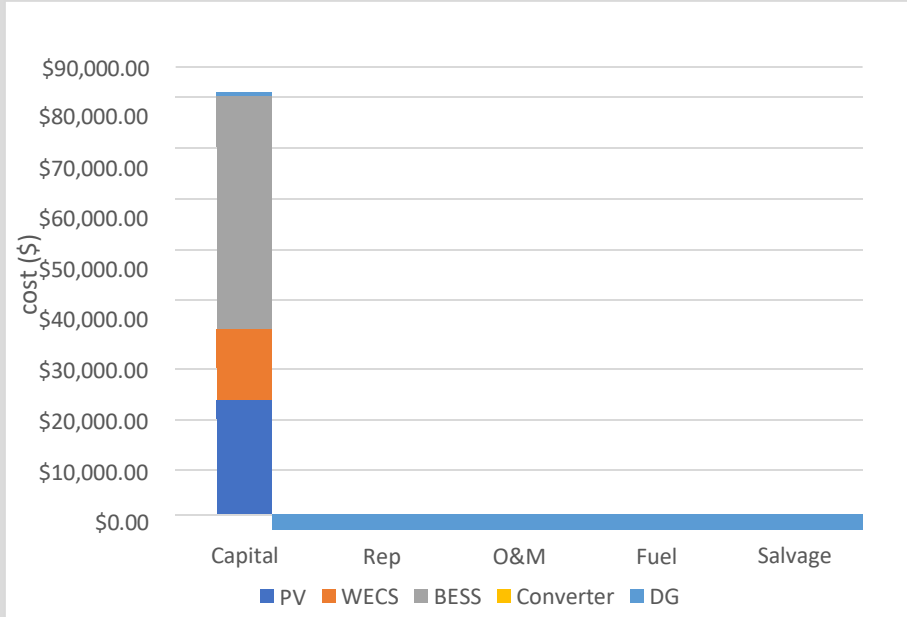

Figure 15: The detailed NPC costs of the hybrid system.

The Annualized cost categorized by hybrid system component is shown in Fig.16.

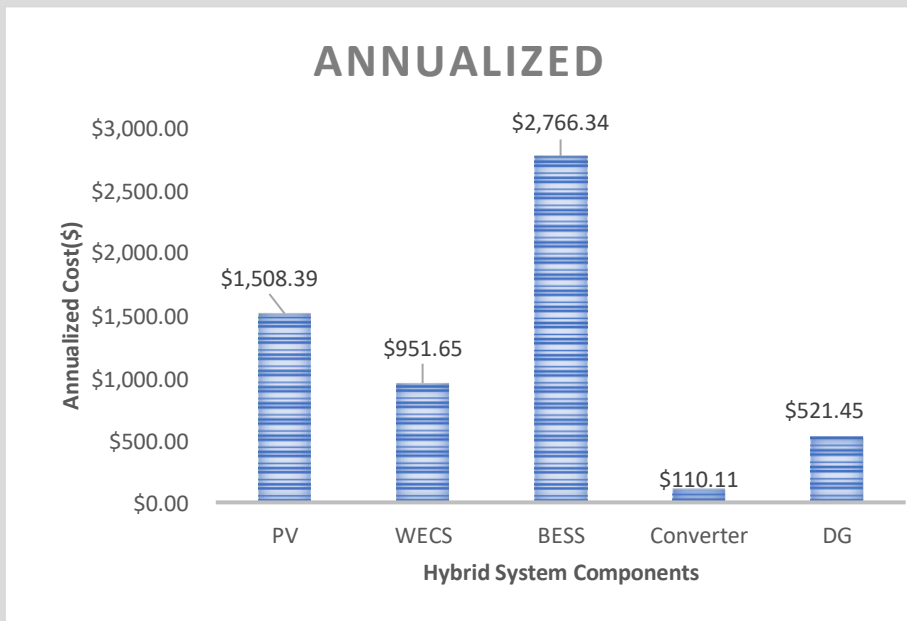

Figure 16: The annualized cost of each component of the hybrid system.

Fig.17 reviews the annualized cash flow for each component of the hybrid system. The highest initial investment cost for BESS and the maximum cost after the investment cost is seen to be the O&M cost. The Fuel cost is the lowest.

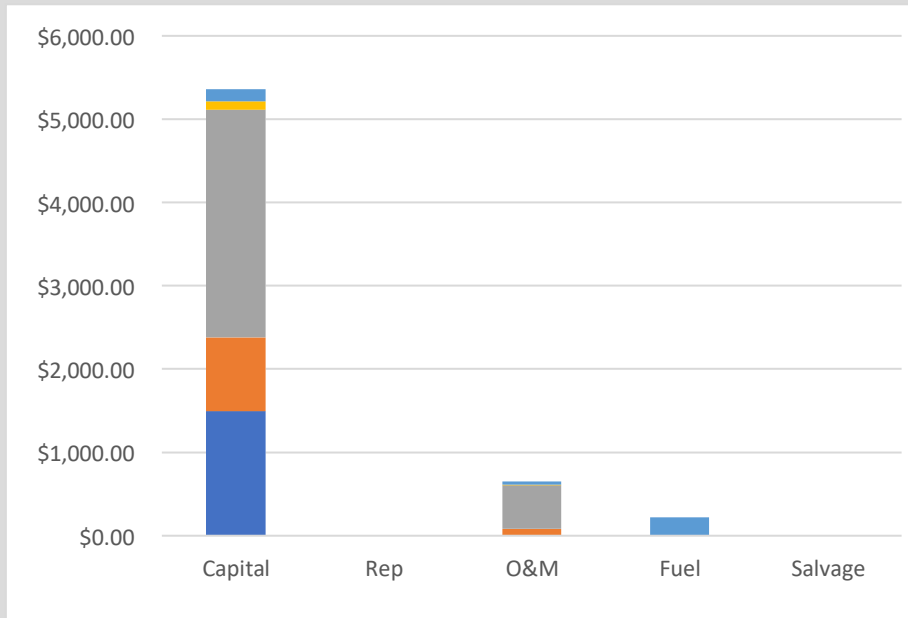

Figure 17: The detailed annualized costs of the hybrid system.

The present worth (Pw) of this configuration is \$39,650, the annual worth (Aw) is 3714\$/yr, the return-on-investment percentage (ROR) 17.1%, internal rate of return (i) 16.7%, the simple payback period (SPP) is 5.85yrs and the discounted payback (DPP) is 6.76yrs.

### **Configuration 2: WECS and BESS with DG.**

The optimization analysis shows that the hybrid system considered of WECS/BESS with DG is another simulation of the most economic hybrid systems. It includes 9WECSs, 232 batteries, DG of 45kW and 46.6kW converter capacity.

The total capital cost of the optimum hybrid system includes the capital cost, replacement cost and O&M cost and salvage cost is about \$212,058, which is NPC of the system. The COE produced by this configuration is \$0.198.

The total electricity production of the system 283,701kWh/yr and the renewable energy fraction 98%.

The monthly average electric production of the hybrid system components is illustrated in Fig.18.

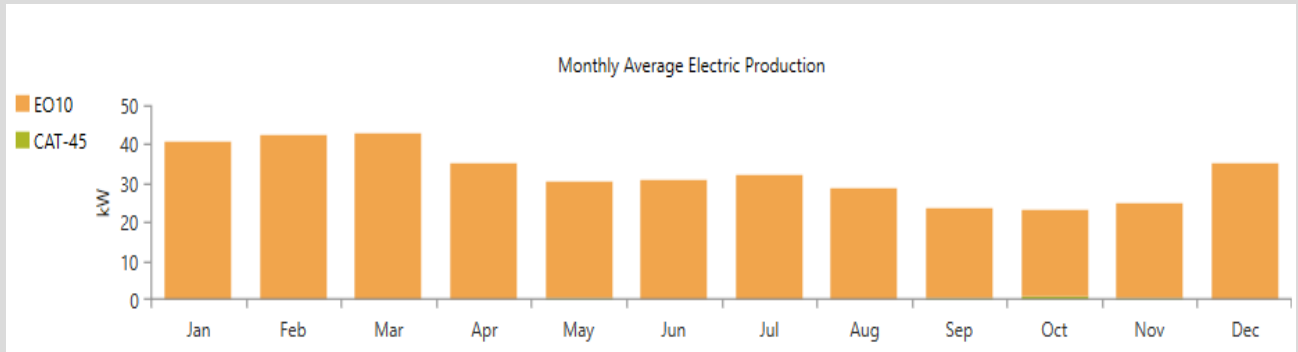

Figure 18: Monthly average electric production of the hybrid system.

The annual AC primary load is 67,526kWh/yr and the annual excess electricity production 206,988kWh/yr is about 59.8% from the total annual energy produced.

The total energy production annually from WECS is 282,383 kWh/yr, which is about 99.5% from the total annual energy produced, and 418% from the AC primary load (wind penetration). The number of operational hours is 5956hrs/yr and the CF is 35.8%. The mean output is 32.2 kW and the COE of energy from WECS system 0.00758\$/kWh.

For the system converter, the capacity of the inverter 46.6kW, the mean output 2.73kW, the max output 18.5kW, the CF 5.85%, the hours of operation 3615hrs/yr, the output energy 23 882kWh/yr and the input energy 25 139kWh/yr. The capacity of the rectifier 46.6kW, the mean output 3.59kW, the max output 18.5kW, the CF 7.7%, the hours of operation 5145hrs/yr, the output energy 31,415kWh/yr and the input energy 1653kWh/yr.

For the batteries system, No. of batteries is 232, string size 4battries, 58string, the bus voltage 48V, the autonomy is 50.2hr, the nominal capacity is 645kWh, usable nominal capacity387kWh, lifetime throughput 387,440kWh, the expected life 13.8yr. The input energy is 31,415kWh/yr, the output energy 25,139kWh/yr, storage depletion 7.3kWh/yr and the annual throughput 28,106kWh/yr.

The electrical production annually from diesel generator is 1319kWh/yr, which is about 0.465% from the total annual energy produced. The annual operational hours 117hrs/yr and the CF is about 0.335%. The fixed generation cost is US\$12.2/h; the specific diesel consumption is 0.486L/kWh while the annual diesel consumption is 640L. the electrical efficiency 20.9% and the operational life 12.8yr.

The avg fuel per day is 1.75L/day and the avg fuel per hour is 0.0731L/hour.

The values of emitted emissions of carbon dioxide, carbon monoxide, unburned hydrocarbons, particulate matter, sulfur dioxide and nitrogen oxides are 1694kg/yr, 0, 0, 0, 4.2kg/yr and 0, respectively.

The NPC categorized by hybrid system component is shown in Fig.19, which shows that the BESS has the highest NPC while the Converter has the lowest.

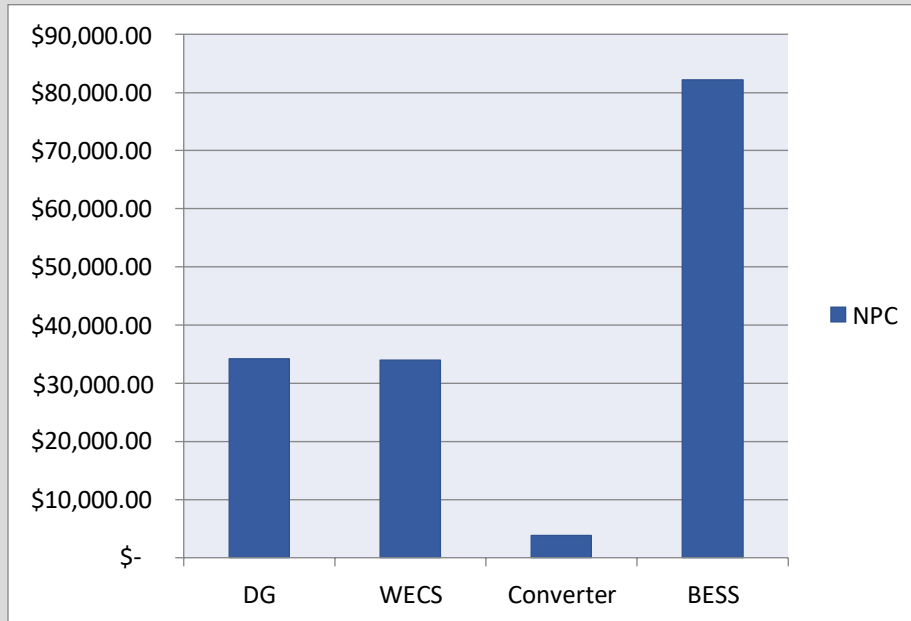

Figure 19: The net present value categorizing by hybrid system components.

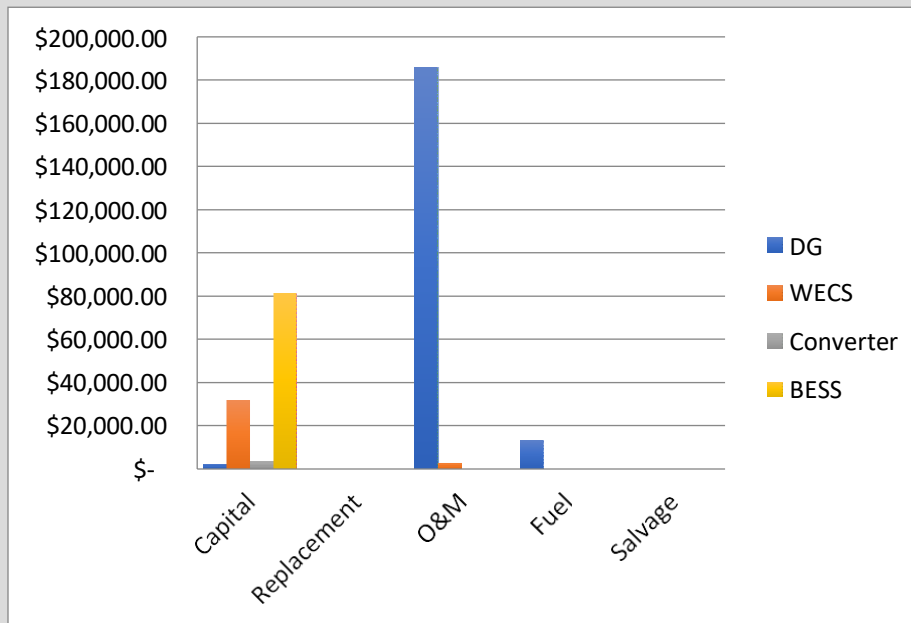

Figure 20: The detailed NPC costs of the hybrid system.

The Annualized cost categorized by hybrid system component is shown in Fig.21, which shows that the BESS has the highest annualized cost while the Converter has the lowest.

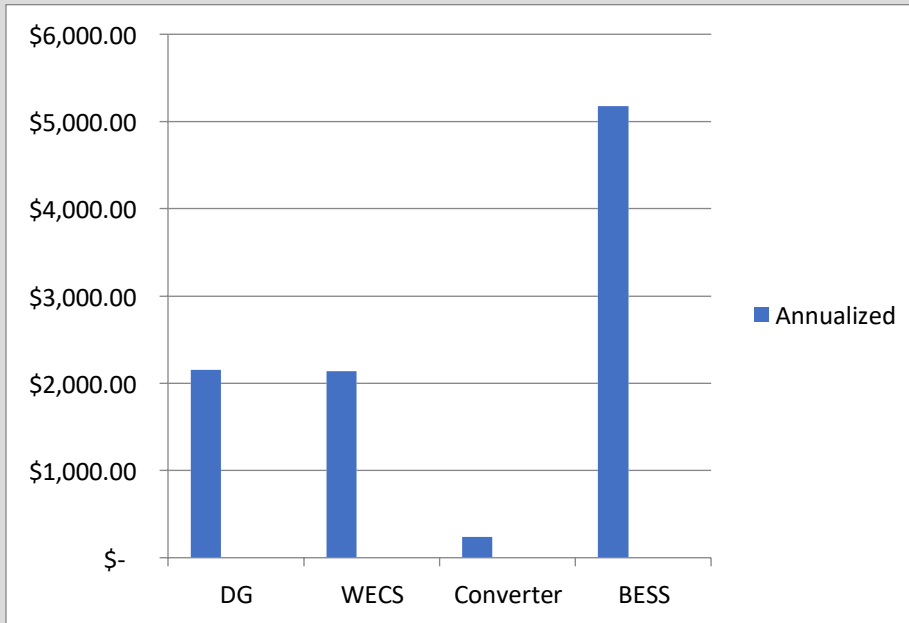

Figure 21: The annualized cost of the hybrid system components.

Fig. 22 reviews the annualized cash flow for each component of the hybrid system. The highest initial investment cost for BESS and the maximum cost after the investment cost is seen to be the O&M cost. The Fuel cost is lowest.

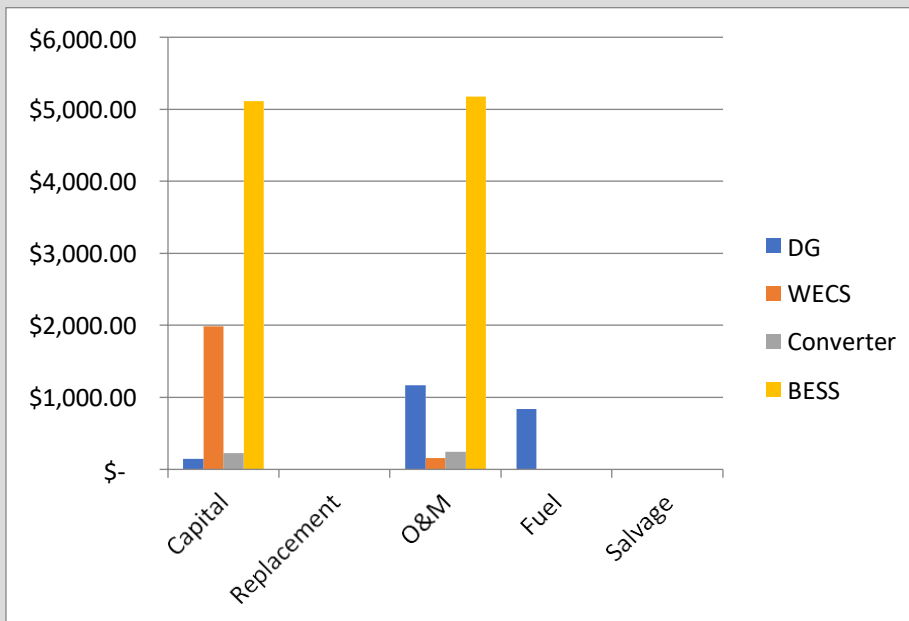

Figure 22: The detailed annualized cost of each component of the hybrid system.

The Pw of this configuration is (\$21,526), the Aw is (2017\$/yr), the ROR 3.9% and the SPP 10.7yrs.

### Configuration 3: PVECS and BESS with DG.

Another configuration of the off-grid hybrid energy system was obtained which using PVECS modules with 89.2kW, 180 batteries, 45kW DG and 22.5kW power converter are required.

The total capital cost of the optimum hybrid system includes the capital cost, replacement cost and O&M cost and salvage cost is about \$214,538, which is the NPC of the system. The COE produced by this configuration \$0.2.

The total electricity production of the system 157,133kWh/yr and the renewable energy fraction 98.4%.

The monthly average electric production of the hybrid system components is illustrated in Fig.23.

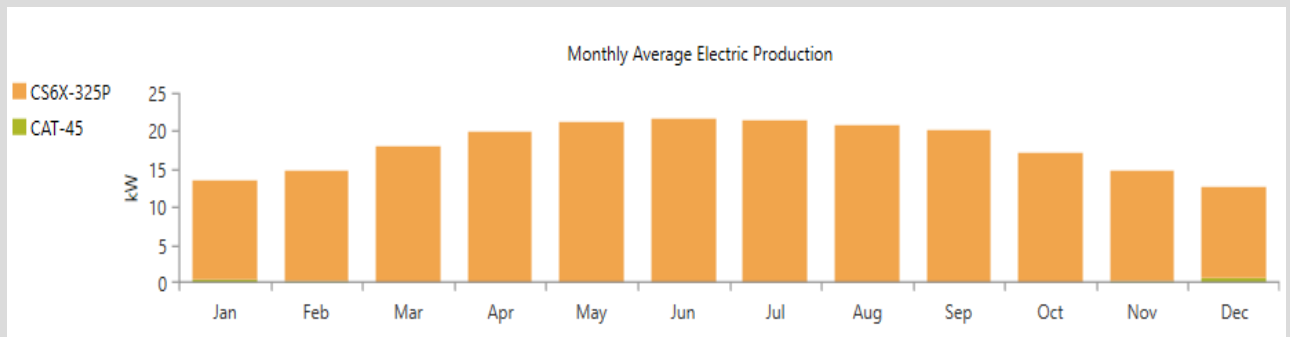

Figure 23: Monthly average electric production of the hybrid system.

The annual AC primary load is 67,526kWh/yr and the annual excess electricity production 77,454 is about 49.3% from the total annual energy produced.

The total energy production annually from PVECS is 156,076kWh, which is about 99.3% from the total annual energy produced, and 231% from the AC primary load (PV penetration). The number of operational hours is 4368hrs/yr and the CF is 20 %. The mean output per day is 428kWh/day and the COE of energy from PVECS system 0.0255\$/kWh.

For the system converter, the capacity of the inverter 22.5kW, the mean output 7.62kW, the max output 20.4kW, the CF 33.8%, the hours of operation 8677hrs/yr, the output energy 66 747kWh/yr and the input energy 70,260kWh/yr. The capacity of the rectifier 22.5kW, the mean output 0.0301kW, the max output 8kW, the CF 0.134%, the hours of operation 83hrs/yr, the output energy 264kWh/yr and the input energy 278kWh/yr.

For the batteries system, No. of batteries is 180, string size 4battries, 45string, the bus voltage 48V, the autonomy is 39hr, the nominal capacity is 501kWh, usable nominal capacity 300kWh, lifetime throughput 300,600kWh, the expected life 7.52yr. The input energy is 44,380kWh/yr, the output energy 35,754kWh/yr, storage depletion 279kWh/yr and the annual throughput 39,974kWh/yr.

The electrical production annually from diesel generator is 1058kWh/yr, which is about 0.673% from the total annual energy produced. The annual operational hours 94hrs/yr and the CF is about 0.268%. The fixed generation cost is US\$12.2/h; the specific diesel consumption is 0.486L/kWh while the annual diesel consumption is 514L. The electrical efficiency 20.9% and the operational life 16yr.

The avg fuel per day is 1.41L/day and the avg fuel per hour is 0.0587L/hour.

The values of emitted emissions of carbon dioxide, carbon monoxide, unburned hydrocarbons, particulate matter, sulfur dioxide and nitrogen oxides are 1360kg/yr, 0, 0, 0, 3.37kg/yr and 0, respectively.

The NPC categorized by hybrid system component is shown in Fig.24, which shows that the BESS has the highest NPC while the Converter has the lowest.

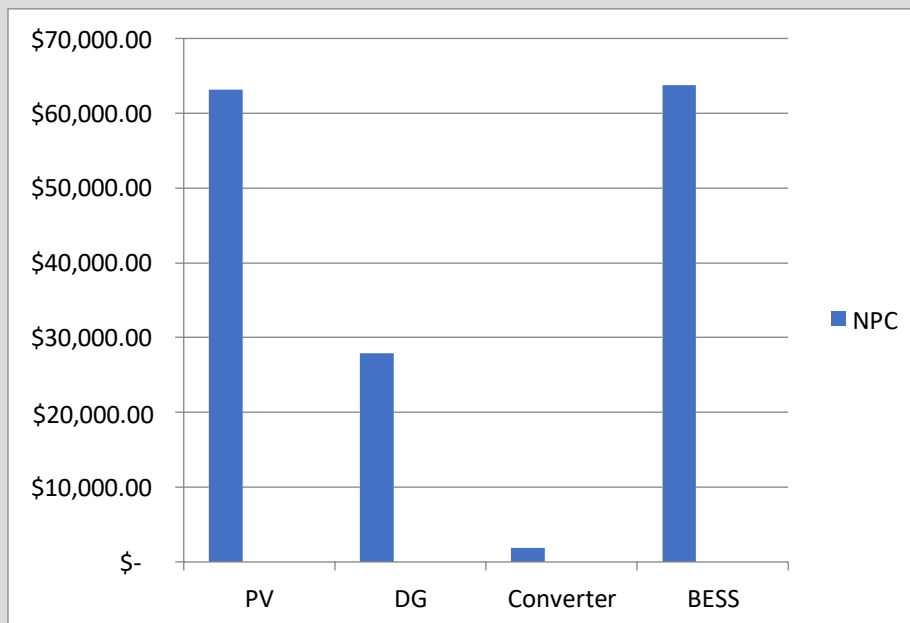

Figure 24: The net present value categorizing by hybrid system components.

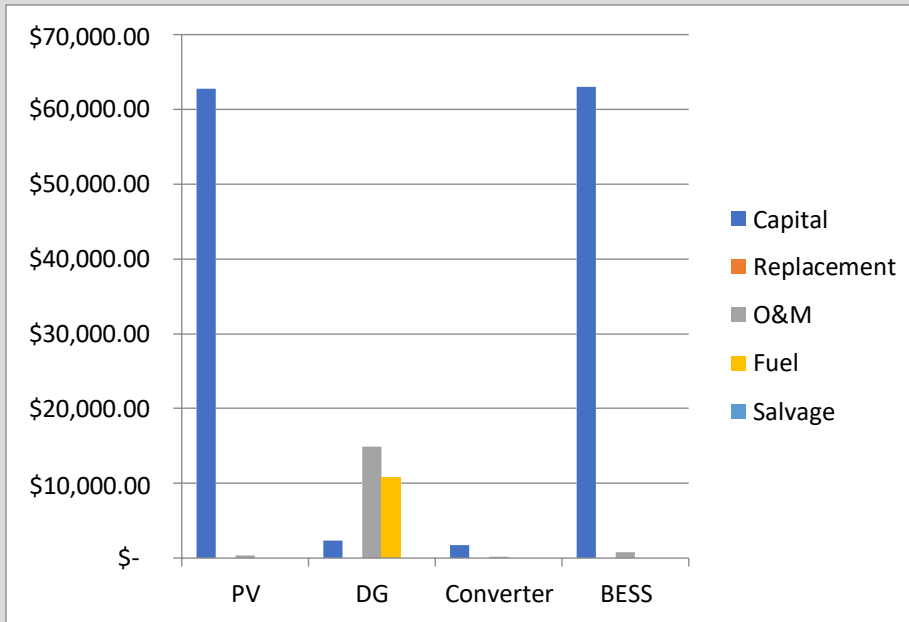

Figure 25: The detailed NPC costs of each component in the system.

The Annualized cost categorized by hybrid system component is shown in Fig.26, which shows that the BESS has the highest annualized cost while the Converter has the lowest.

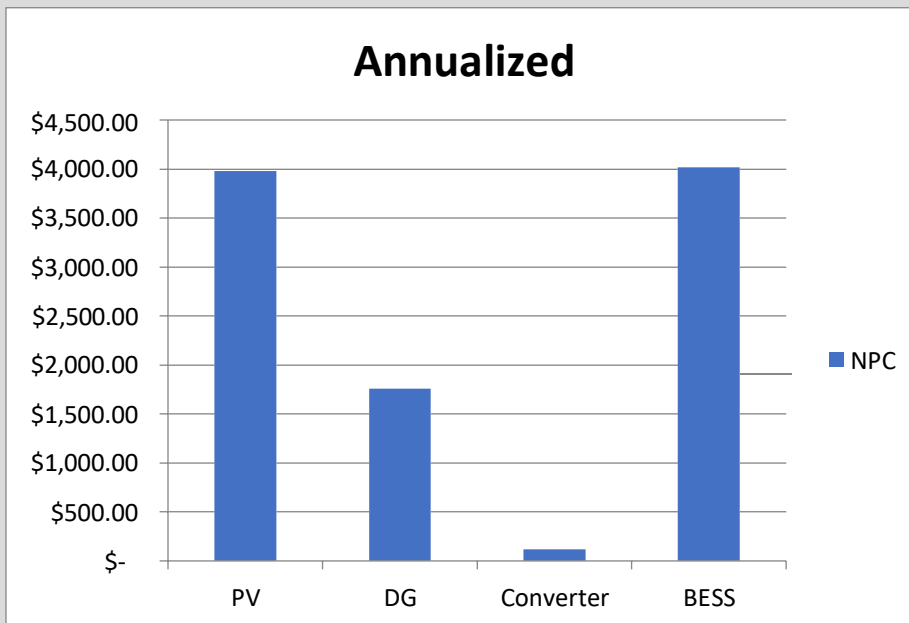

Figure 26: The annualized cost of each component of the hybrid system.

Fig.27 reviews the annualized cash flow for each component of the hybrid system.

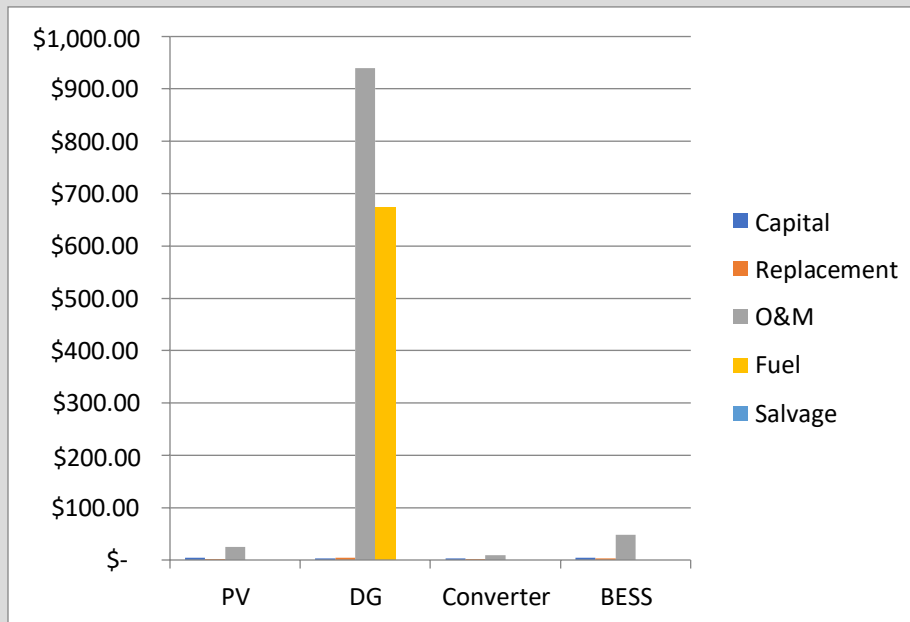

Figure 27: The detailed annualized cost of each component of the hybrid system.

The Pw of this configuration is (\$24,006), the Aw is (2249\$/yr), the ROR percentage 4.1%, i is 0.1% and SPP is 24.59yrs.

#### Configuration 4: PVESC/WECS with DG.

This configuration is not feasible with respect to configuration 1, 2 and 3. It consists of 164kW of PVECS, 30 WECSs and 24.4kW converter.

The total capital cost of the optimum hybrid system includes the capital cost, replacement cost and O&M cost and salvage cost is about \$999,843, which is the NPC. The COE produced by this configuration \$0.932.

The total electricity production of the system 1,258,249kWh/yr and the renewable energy fraction 56.7%.

The monthly average electric production of the hybrid system components is illustrated in Fig.28.

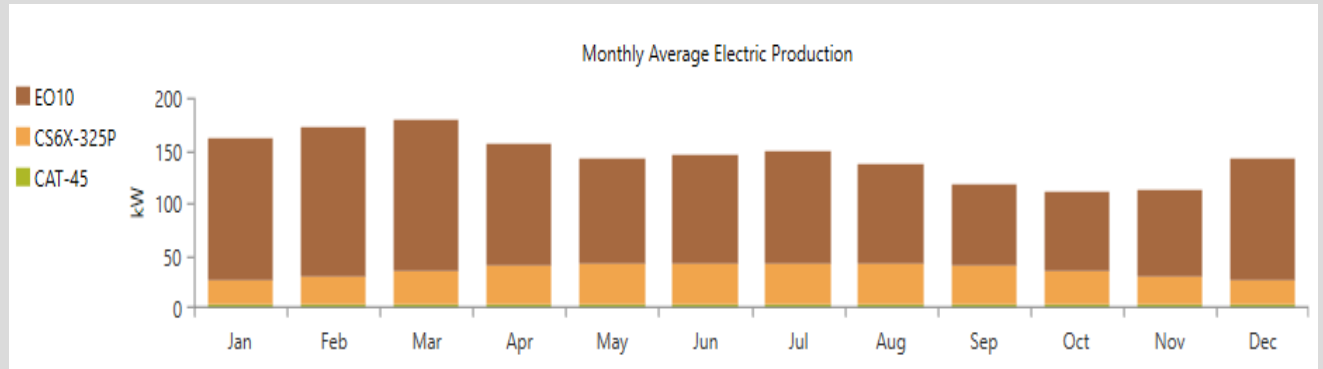

Figure 28: Monthly average electric production of the hybrid system.

The annual AC primary load is 67,526kWh/yr and the annual excess electricity production 1,190,446 is about 94.6% from the total annual energy produced.

The total energy production annually from PVECS is 287,727kWh, which is about 22.9% from the total annual energy produced. The number of operational hours is 4368hrs/yr and the CF is 20 %. The mean output per day is 788 kWh/day and the COE of energy from PVECS system 0.0255\$/kWh.

The total energy production annually from WECS is 941,275kWh, which is about 74.8% from the total annual energy produced. The number of operational hours is 5956hrs/yr and the CF is 35.8%. The mean output is 107 kW and the levelized cost of energy from WECS system 0.00758\$/kWh.

For the system converter, the capacity of the inverter 24.4kW, the mean output 0.599kW, the max output 17.8kW, the CF is 2.45%, the hours of operation 749hrs/yr, the output energy 5251kWh/yr and the input energy 5528kWh/yr. The capacity of the rectifier 24.4kW, the mean output 0kW, the max output 0kW, the CF is 0%, the hours of operation 0hrs/yr, the output energy 0kWh/yr and the input energy 0kWh/yr.

The electrical production annually from diesel generator is 29,246kWh/yr, which is about 2.32% from the total annual energy produced. The annual operational hours 2,597hrs/yr and the CF is about 7.42%. The fixed generation cost is US\$12.2/h; the specific diesel consumption is 0.486L/kWh while the annual diesel consumption is 14,207L. The electrical efficiency 20.9% and the operational life 0.578yr.

The avg fuel per day is 38.9L/day and the avg fuel per hour is 1.62L/hour.

The values of emitted emissions of carbon dioxide, carbon monoxide, unburned hydrocarbons, particulate matter, sulfur dioxide and nitrogen oxides are 37,590kg/yr, 0, 0, 0, 93.2kg/yr and 0, respectively.

The NPC categorized by hybrid system component is shown in Fig.29, which shows that the DG has the highest NPC while the Converter has the lowest.

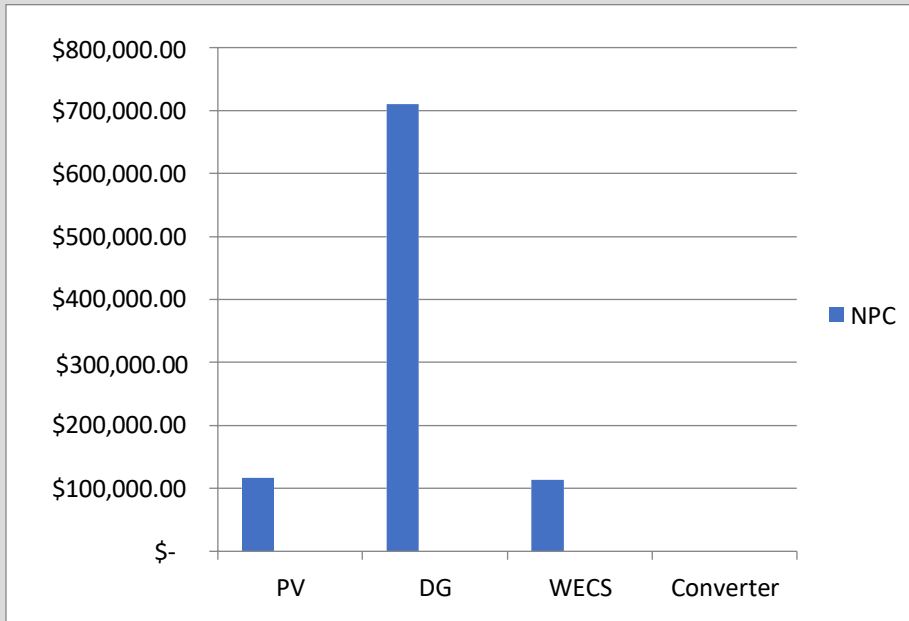

Figure 29: The net present value categorizing by hybrid system components.

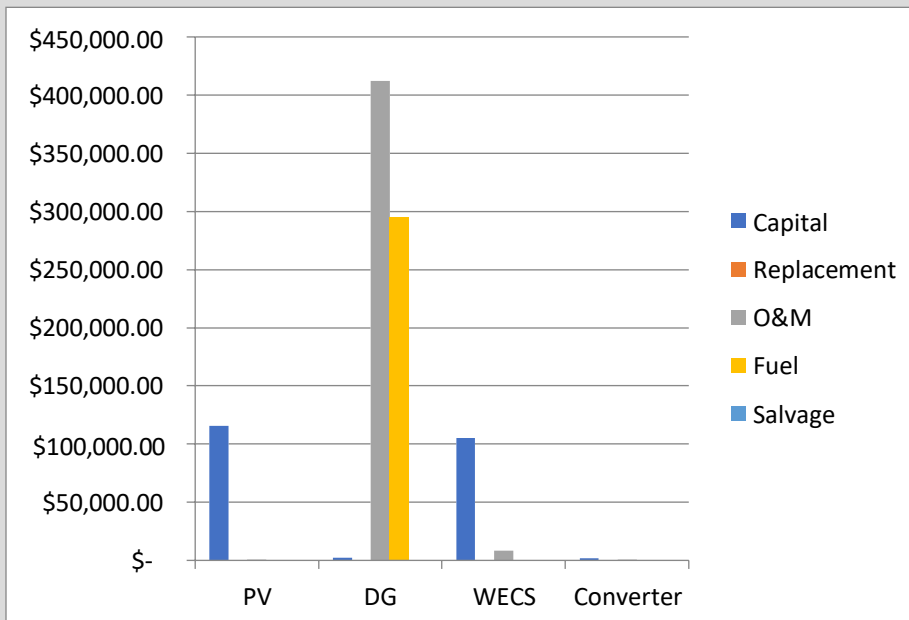

Figure 30: The detailed NPC costs of each component in the system.

The Annualized cost categorized by hybrid system component is shown in Fig.31.

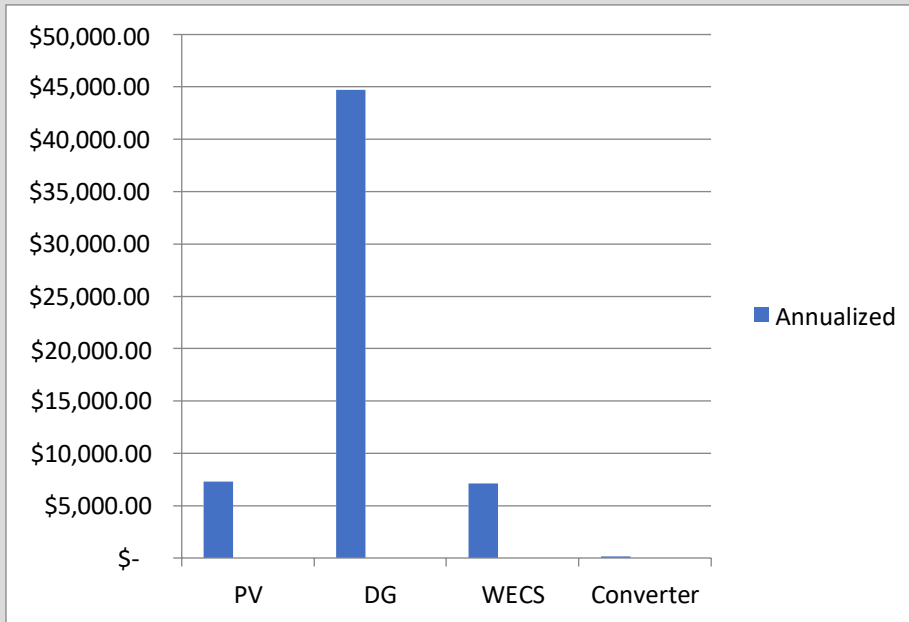

Figure 31: The annualized cost of each component of the hybrid system.

Fig.32 reviews the annualized cash flow for each component of the hybrid system. The highest initial investment cost for PV and the maximum O&M cost of DG.

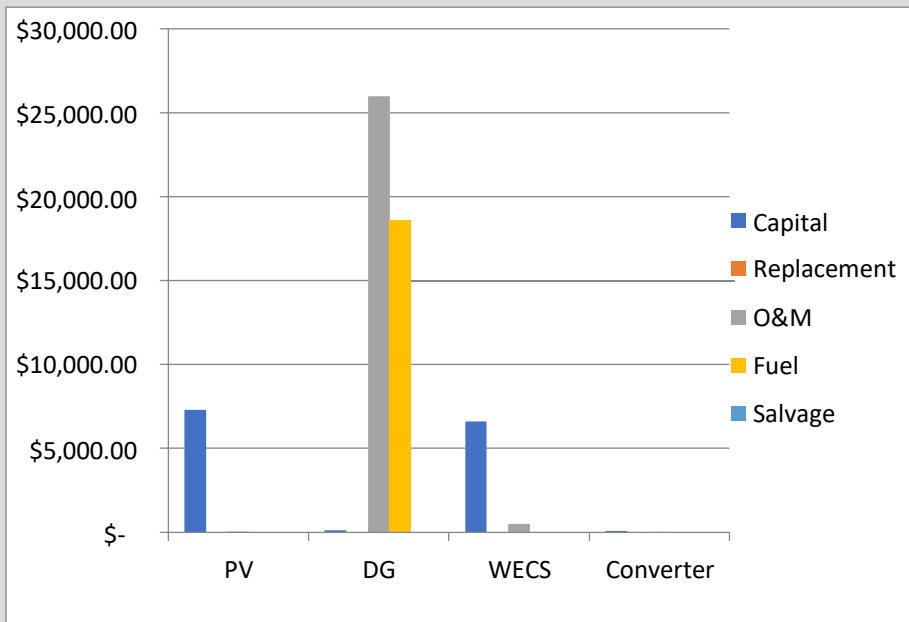

Figure 32: The detailed annualized cost of each component of the hybrid system.

The present worth of this configuration is (\$809,311), the annual worth is (75,815\$/yr), the return-on-investment percentage -25% and the SPP is 10.6yr.

## ON-GRID HYBRID SYSTEM.

### Configuration 1: PVESC/WECS/ Connected Grid with DG.

The optimization analysis shows that the hybrid system considered of PVESC/WECS/Connected Grid with DG is the most economic hybrid system. It includes PVESC with 16.3kW, 4WECSs, 10kW DG and 10.8kW converter capacity.

The total capital cost of the optimum hybrid system includes the capital cost, replacement cost and O&M cost and salvage cost is about \$135,572, which is the of the system NPC. The COE produced by this configuration \$0.0495.

The monthly average electric production of the hybrid system components is illustrated in Fig.33.

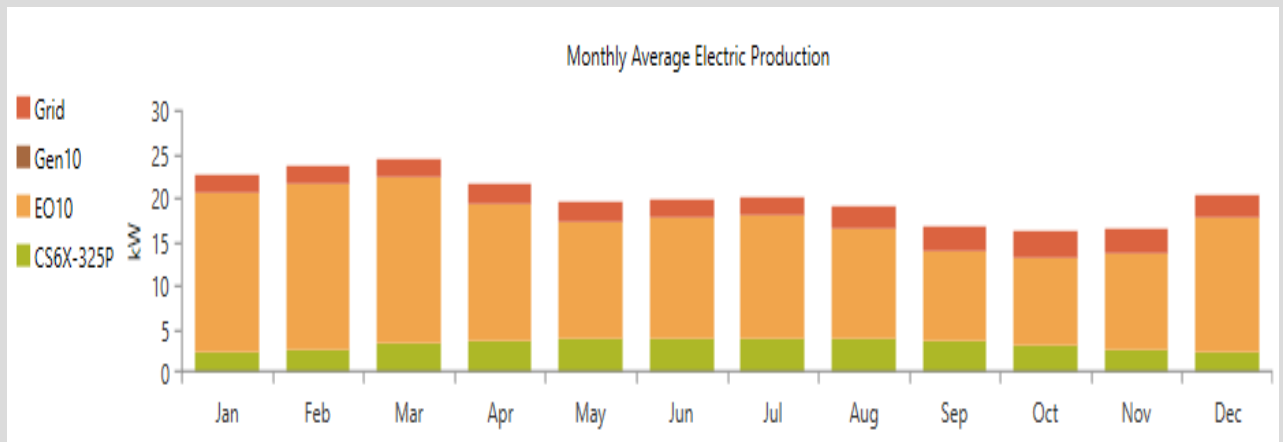

Figure 33: Monthly average electric production of the hybrid system.

The annual AC primary load is 67,526kWh/yr and the annual excess electricity production 1276 is about 0.729% from the total annual energy produced.

The total energy production annually from PVECS is 28 524kWh, which is about 16.3% from the total annual energy produced, and 42.2% from the AC primary load (PV penetration). The number of operational hours is 4368hrs/yr and the CF is 20 %. The mean output per day is 78.1kWh/day and the COE of energy from PVECS system 0.0255\$/kWh.

The total energy production annually from WECS is 125,503 kWh, which is about 71.7% from the total annual energy produced, and 39.2% from the AC primary load (WECS penetration). The number of operational hours is 5956hrs/yr and the CF is 35.8%. The mean output is 14.3 kW and the COE of energy from WECS system 0.00758\$/kWh.

For the system converter, the capacity of the inverter 10.8kW, the mean output 2.95kW, the max output 10.8kW, the CF 27.5%, the hours of operation 4368hrs/yr, the output energy 25,886kWh/yr and the input energy 27,248kWh/yr. The capacity of the rectifier 10.8kW, the mean output 0kW, the max output 0kW, the CF 0%, the hours of operation 0hrs/yr, the output energy 0kWh/yr and the input energy 0kWh/yr.

The electrical production annually from diesel generator is 0kWh/yr, which is about 0% from the total annual energy produced. The annual operational hours 0hrs/yr and the capacity factor is about 0%. The fixed generation cost is US\$30.6/h; the specific diesel consumption is 0L/kWh while the annual diesel consumption is 0L. The electrical efficiency 0% and the operational life 1000yr.

The avg fuel per day is 0L/day and the avg fuel per hour is 0L/hour.

The values of emitted emissions of carbon dioxide, carbon monoxide, unburned hydrocarbons, particulate matter, sulfur dioxide and nitrogen oxides are -53,001kg/yr, -33,545kg/yr, -29,016kg/yr, 0, -230kg/yr and -112kg/yr, respectively.

The total energy production from the grid is 20,955kWh/yr, which is about 12% from the total annual energy produced.

The NPC categorized by hybrid system component is shown in Fig.34, which shows that the Grid has the highest NPC while the Converter has the lowest.

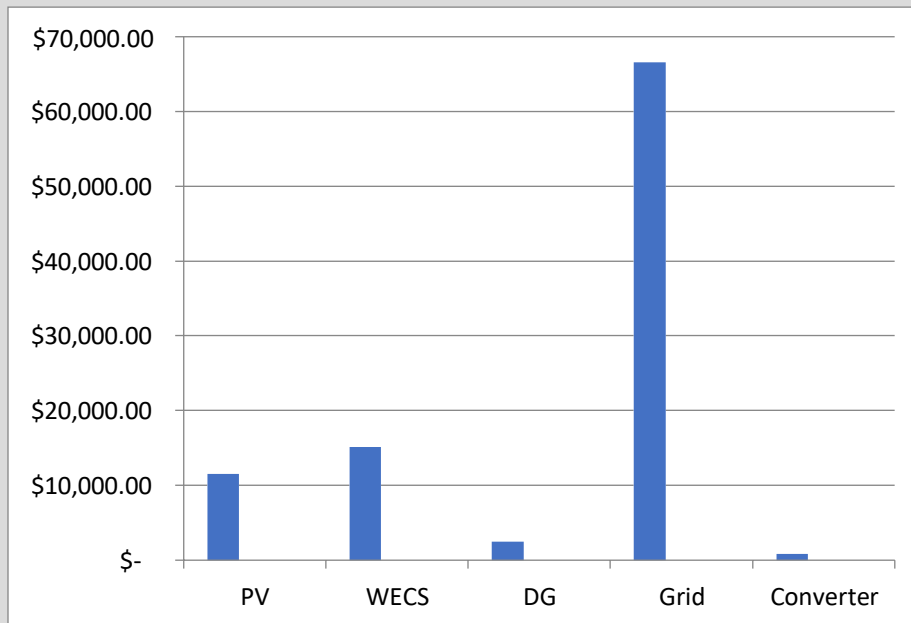

Figure 34: The net present value categorizing by hybrid system components.

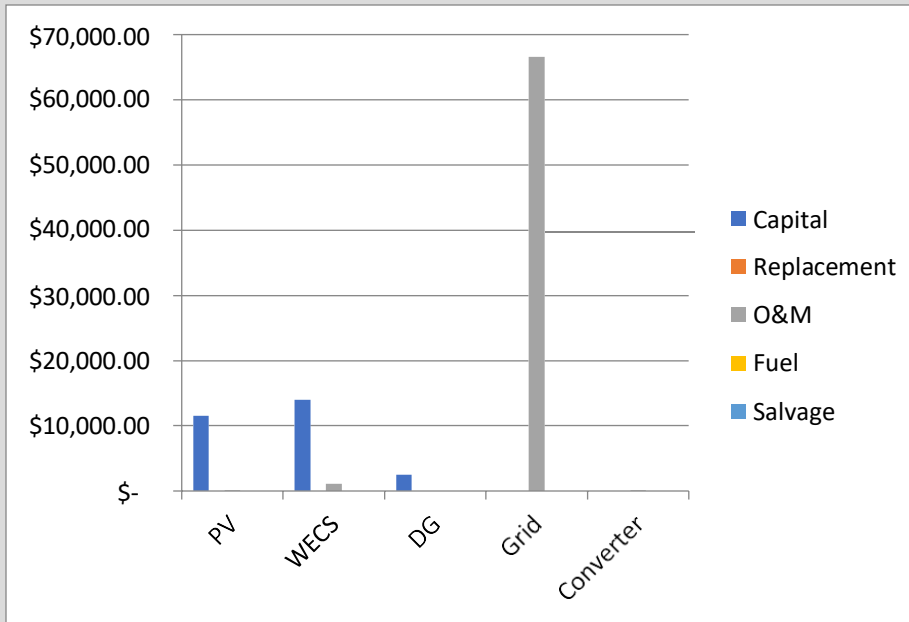

Figure 35: The detailed NPC costs of each component in the system.

The Annualized cost categorized by hybrid system component is shown in Fig.36.

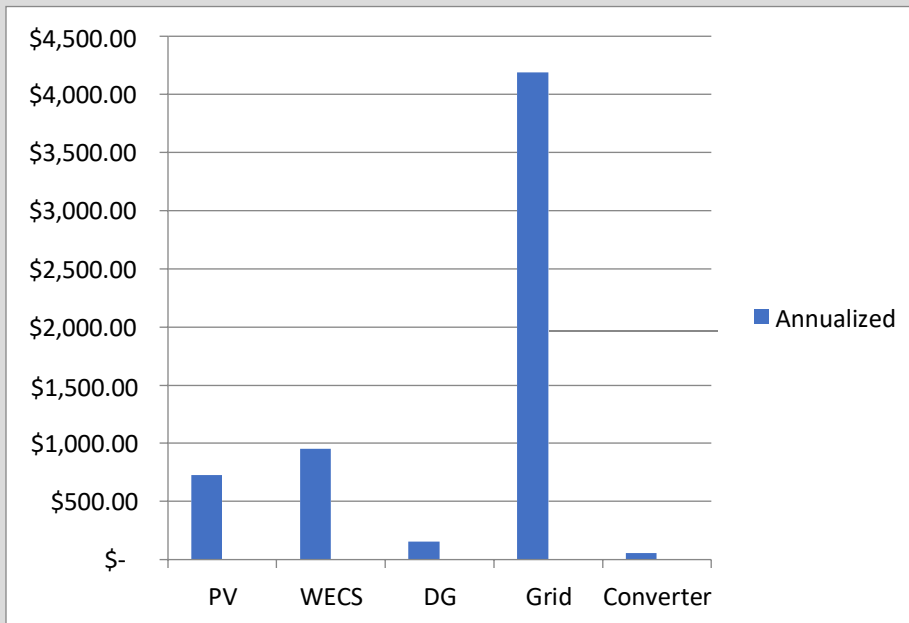

Figure 36: The annualized cost of each component of the hybrid system.

Fig.37 reviews the annualized cash flow for each component of the hybrid system. The highest initial investment cost for WECS and the maximum O&M cost is of the Grid. The Fuel cost is lowest.

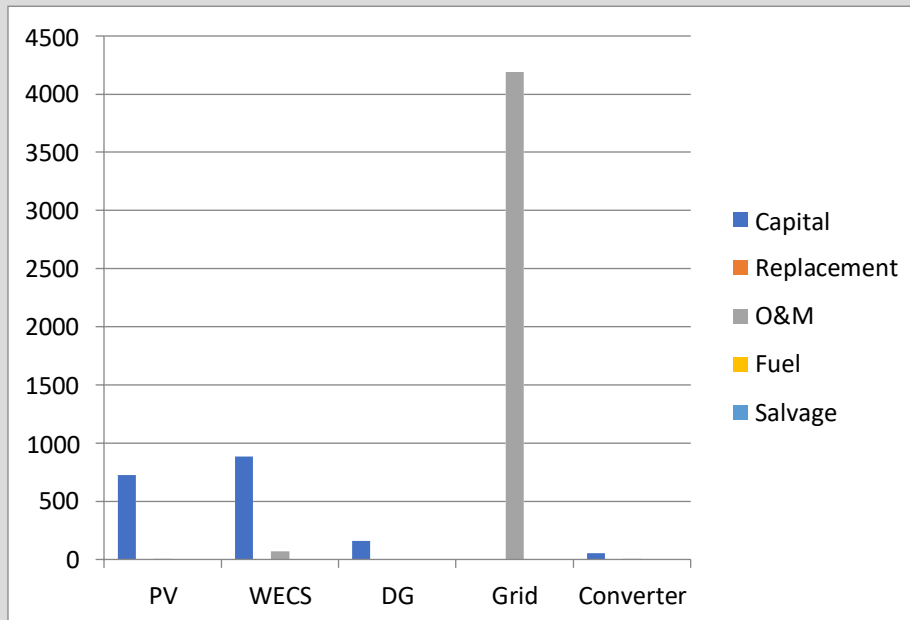

Figure 37: The detailed annualized cost of each component of the hybrid system.

The Pw of this configuration is \$120,367, the Aw is 11,276\$/yr, the ROR percentage 35.1%, the percentage i 35.1%, the SPP is 2.85yrs and the DPP is 3.07yrs.

### Configuration 2: WECS and Connected Grid with DG.

Another configuration of the on-grid hybrid energy system was obtained which using 5WECSs and 10kW DG.

The total capital cost of the optimum hybrid system includes the capital cost, replacement cost and O&M cost and salvage cost is about \$148,189, which is the NPC of energy. The COE produced by this configuration \$0.0506.

The total electricity production of the system 184,530kWh/yr and the renewable energy fraction 85%.

The monthly average electric production of the hybrid system components is illustrated in Fig.38.

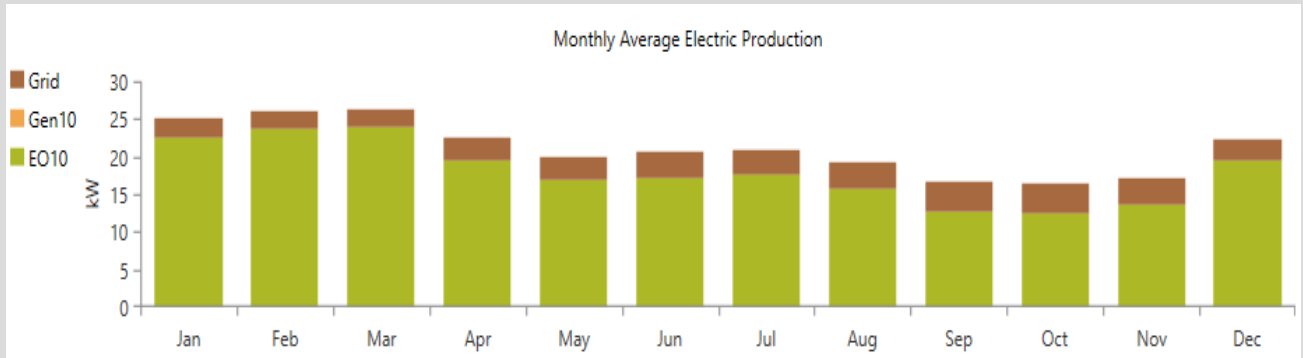

Figure 38: Monthly average electric production of the hybrid system.

The annual AC primary load is 67,526kWh/yr, which is 36.6% from the total consumption and the annual excess electricity production is 0.

The total energy production annually from WECS is 156,879kWh, which is about 85% from the total annual energy produced. The number of operational hours is 5956hrs/yr and the CF is 35.8%. The mean output is 17.9 kW and the COE of energy from WECS system 0.00758\$/kWh.

The electrical production annually from diesel generator is 0kWh/yr, which is about 0% from the total annual energy produced. The annual operational hours 1000hrs/yr and the CF is about 0%. The fixed generation cost is US\$30.6/h; the specific diesel consumption is 0L/kWh while the annual diesel consumption is 0L. The electrical efficiency 0% and the operational life 1000yr.

The avg fuel per day is 0L/day and the avg fuel per hour is 0L/hour.

The values of emitted emissions of carbon dioxide, carbon monoxide, unburned hydrocarbons, particulate matter, sulfur dioxide and nitrogen oxides are -56,471kg/yr, -35,741kg/yr, -30,916kg/yr, 0, -245kg/yr and -120kg/yr, respectively.

The total energy production from the grid is 27,651kWh/yr, which is about 15% from the total annual energy produced.

The NPC categorized by hybrid system component is shown in Fig.39, which shows that the Grid has the highest NPC while the DG has the lowest.

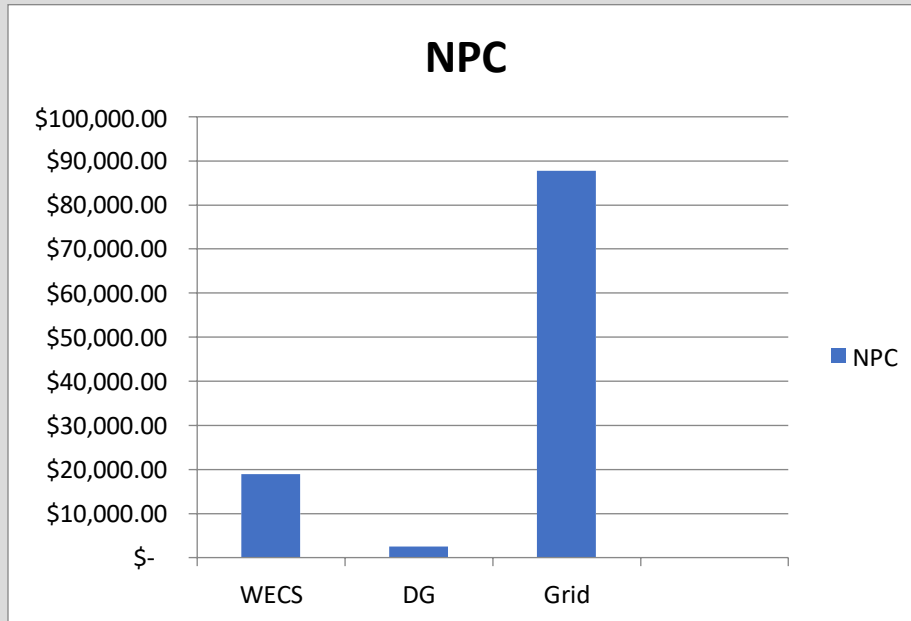

Figure 39: The net present value categorizing by hybrid system components.

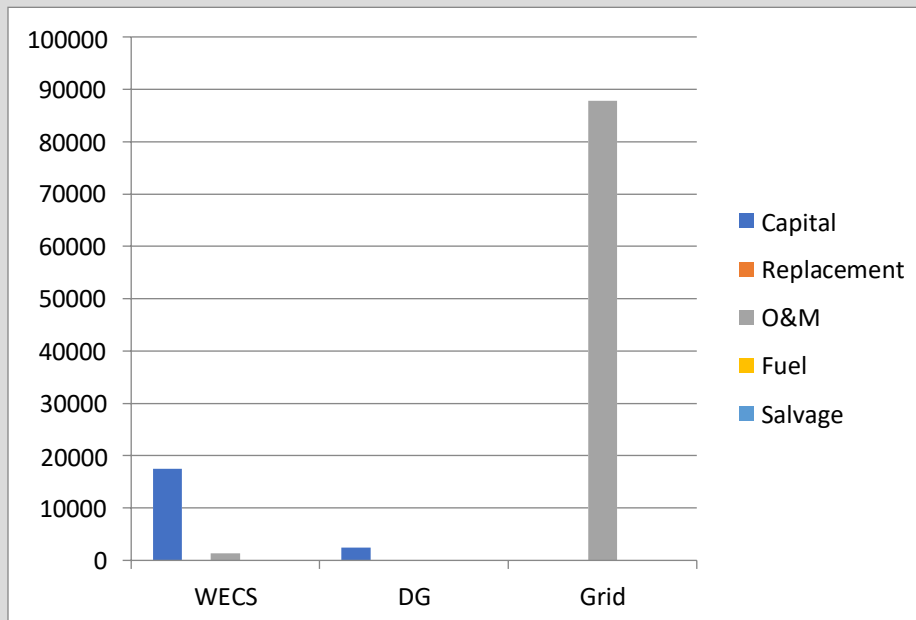

Figure 40: The detailed NPC costs of each component in the system.

The Annualized cost categorized by hybrid system component is shown in Fig.41.

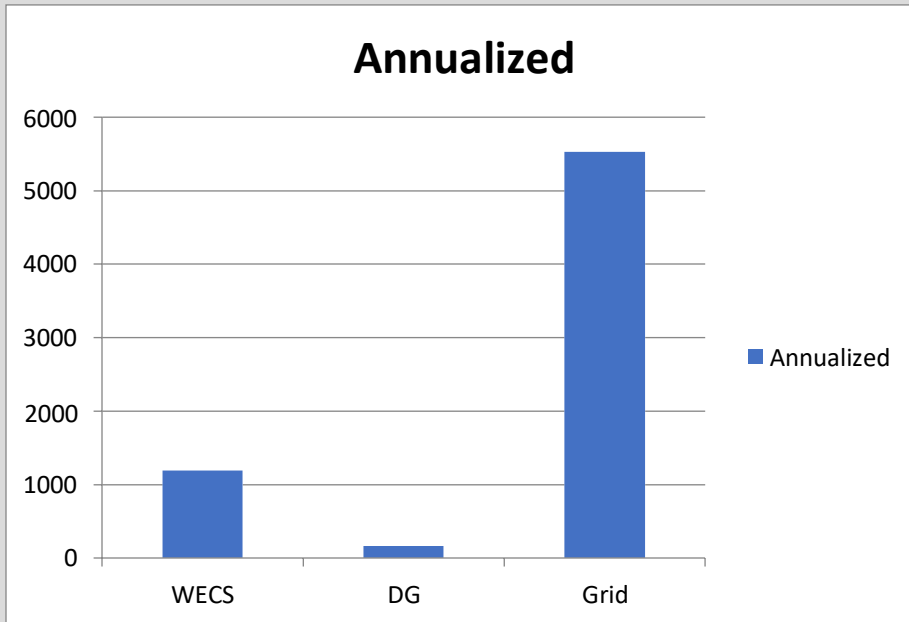

Figure 41: The annualized cost of each component of the hybrid system.

Fig.42 reviews the annualized cash flow for each component of the hybrid system. The highest initial investment cost for WECS. The highest O&M cost is of Grid.

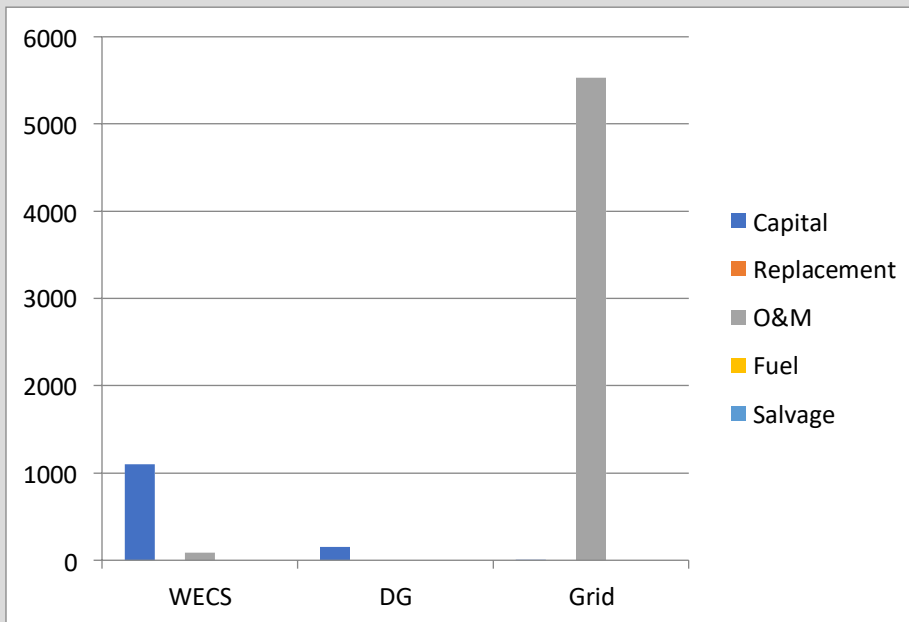

Figure 42: The detailed annualized cost of each component of the hybrid system.

The Pw of this configuration is \$107,751, the Aw is 10,094\$/yr, the ROR percentage 45.1%, i 45.1% and SPP is 2.22yrs.

### Configuration 3: PVECS and Connected Grid with DG.

Another configuration of the on-grid hybrid energy system was obtained which using PVECS of 29.1kW and 10kW DG.

The total capital cost of the optimum hybrid system includes the capital cost, replacement cost and O&M cost and salvage cost is about \$189,003, which is the NPC of energy. The COE produced by this configuration \$0.148.

The total electricity production of the system 90,451kWh/yr and the renewable energy fraction 50.9%.

The monthly average electric production of the hybrid system components is illustrated in Fig.43.

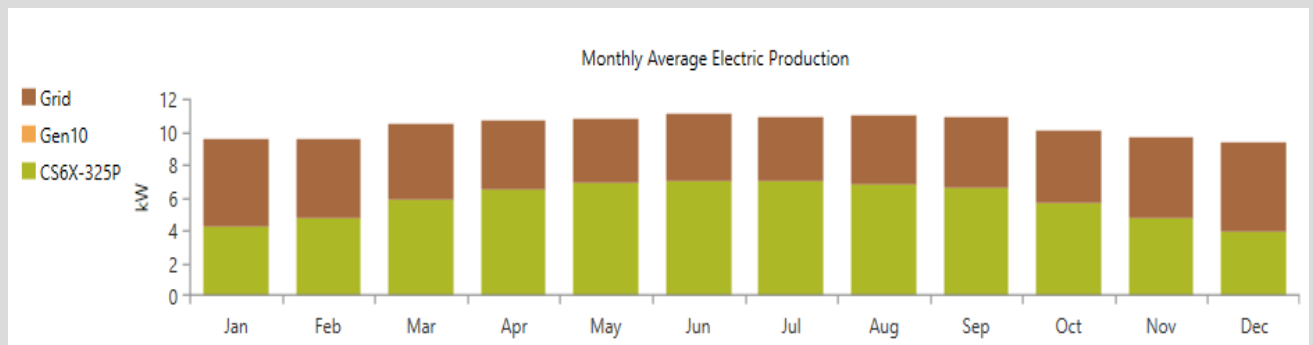

Figure 43: Monthly average electric production of the hybrid system.

The annual AC primary load is 67,526kWh/yr, which is 83.8% from the total consumption and the annual excess electricity production is 7680kWh/yr, which is about 8.49%.

The total energy production annually from PVECS is 50,867kWh, which is about 56.2% from the total annual energy produced. The number of operational hours is 4368hrs/yr and the CF is 20%. The mean output is 5.81kW and the COE of energy from PVECS system 0.0255\$/kWh. The PV penetration is 75.3%.

For the system converter, the capacity of the inverter 14.9kW, the mean output 4.68kW, the max output 1498kW, the CF 31.5%, the hours of operation 4368hrs/yr, the output energy 41,028kWh/yr and the input energy 43,188kWh/yr. The capacity of the rectifier 14.9kW, the mean output 0kW, the max output 0kW, the CF 0%, the hours of operation 0hrs/yr, the output energy 0kWh/yr and the input energy 0kWh/yr.

The electrical production annually from diesel generator is 0kWh/yr, which is about 0% from the total annual energy produced. The annual operational hours 1000hrs/yr and the CF is about 0%. The fixed generation cost is US\$30.6/h; the specific diesel consumption is 0L/kWh while the annual diesel consumption is 0L. The electrical efficiency 0% and the operational life 1000yr.

The avg fuel per day is 0L/day and the avg fuel per hour is 0L/hour.

The values of emitted emissions of carbon dioxide, carbon monoxide, unburned hydrocarbons, particulate matter, sulfur dioxide and nitrogen oxides are 16,747kg/yr, 10,599kg/yr, 9168kg/yr, 0, 72.6kg/yr and 35.5kg/yr, respectively.

The total energy production from the grid is 39,584kWh/yr, which is about 43.8% from the total annual energy produced.

The NPC categorized by hybrid system component is shown in Fig.44, which shows that the PV has the highest NPC while the BESS has the lowest.

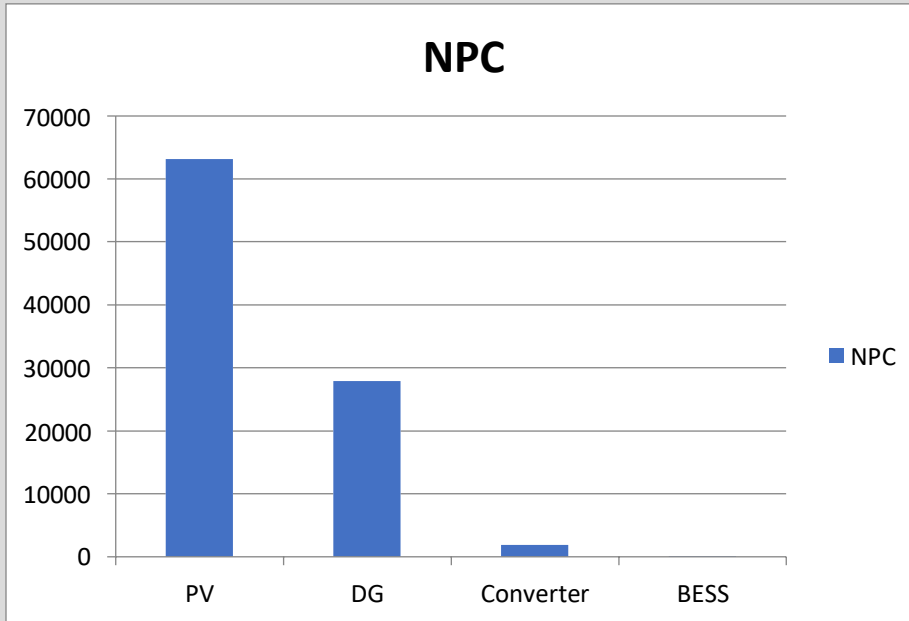

Figure 44: The net present value categorizing by hybrid system components.

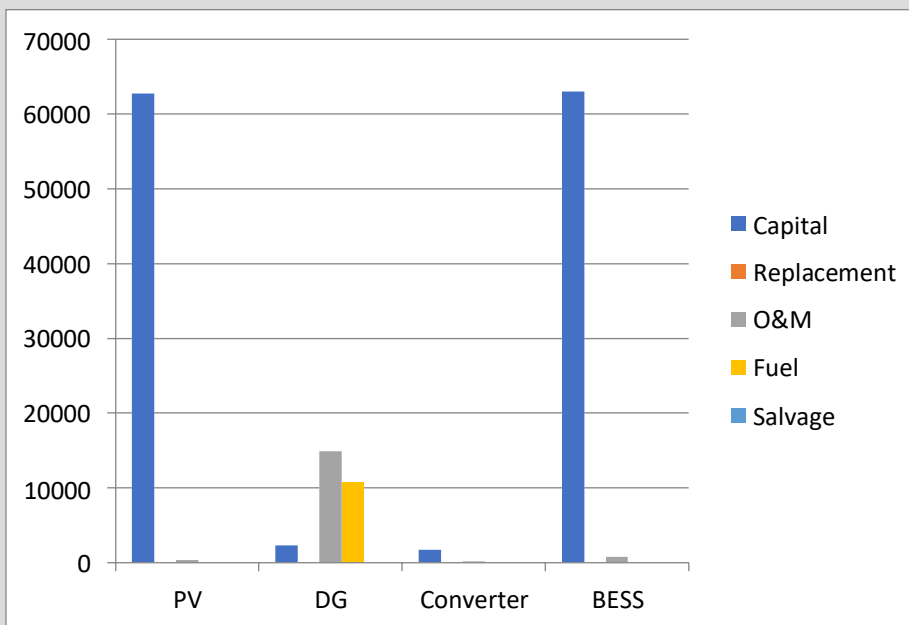

Figure 45: The detailed NPC costs of each component in the system.

The Annualized cost categorized by hybrid system component is shown in Fig.46.

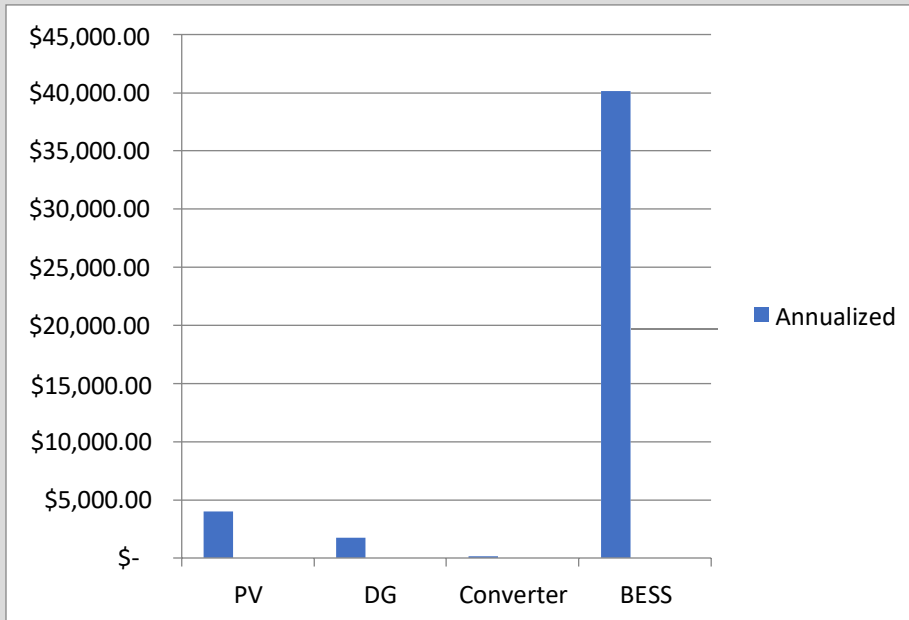

Figure 46: The annualized cost of each component of the hybrid system.

Fig.47 reviews the annualized cash flow for each component of the hybrid system. The highest initial investment cost for BESS and the maximum cost after the investment cost is seen to be the O&M cost. The Fuel cost is lowest.

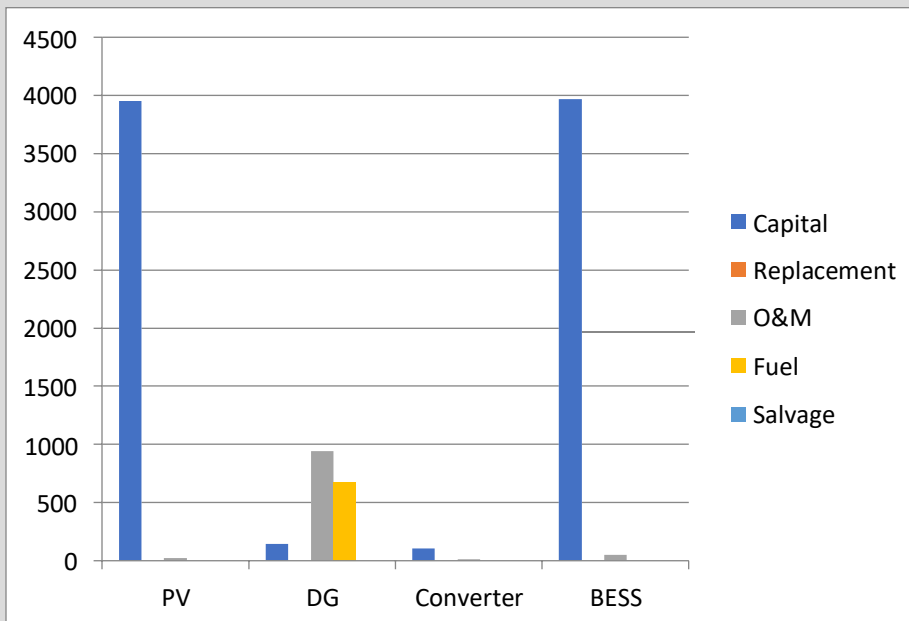

Figure 47: The detailed annualized cost of each component of the hybrid system.

The Pw of this configuration is \$66,936, the Aw is 6270\$/yr, the ROR percentage 25.8%, i 25.7%, SPP is 3.87yrs and DPP is 4.28yrs.

#### Configuration 4: PVECS and Connected Grid with DG.

Another configuration of the on-grid hybrid energy system was obtained which using the grid and 10kW DG.

The total capital cost of the optimum hybrid system includes the capital cost, replacement cost and O&M cost and salvage cost is about \$255,595, which is the NPC of energy. The COE produced by this configuration \$0.239.

The total electricity production of the system 67526kWh/yr and the renewable energy fraction 0%.

The monthly average electric production of the hybrid system components is illustrated in Fig.48.

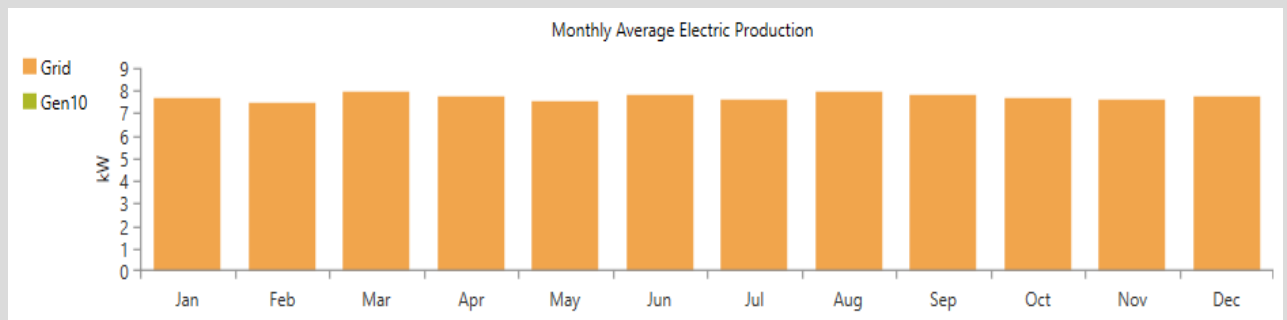

Figure 48: Monthly average electric production of the hybrid system.

The annual AC primary load is 67,526kWh/yr, which is 100% and the annual excess

The electrical production annually from diesel generator is 0kWh/yr, which is about 0% from the total annual energy produced. The annual operational hours 1000hrs/yr and the CF is about 0%. The fixed generation cost is US\$30.6/h; the specific diesel consumption is 0L/kWh while the annual diesel consumption is 0L. The electrical efficiency 0% and the operational life 1000yr.

The avg fuel per day is 0L/day and the avg fuel per hour is 0L/hour.

The values of emitted emissions of carbon dioxide, carbon monoxide, unburned hydrocarbons, particulate matter, sulfur dioxide and nitrogen oxides are 42,677kg/yr, 27,011kg/yr, 23,364kg/yr, 0, 185kg/yr and 90.5kg/yr, respectively.

The total energy production from the grid is 67,526kWh/yr, which is about 100% from the total annual energy produced.

The NPC categorized by hybrid system component is shown in Fig.49, which shows that the DG has the highest NPC while the Converter has the lowest.

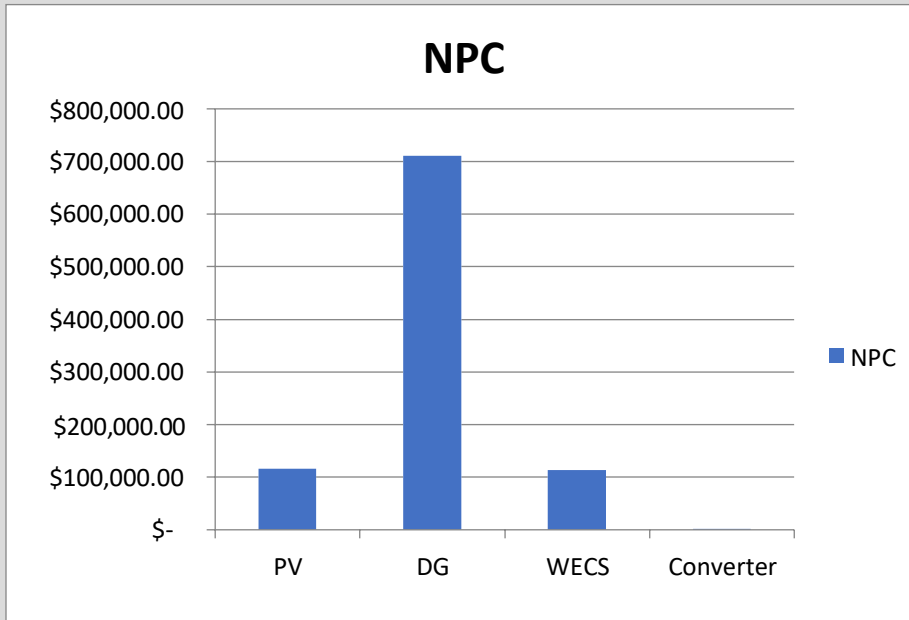

Figure 49: The net present value categorizing by hybrid system components.

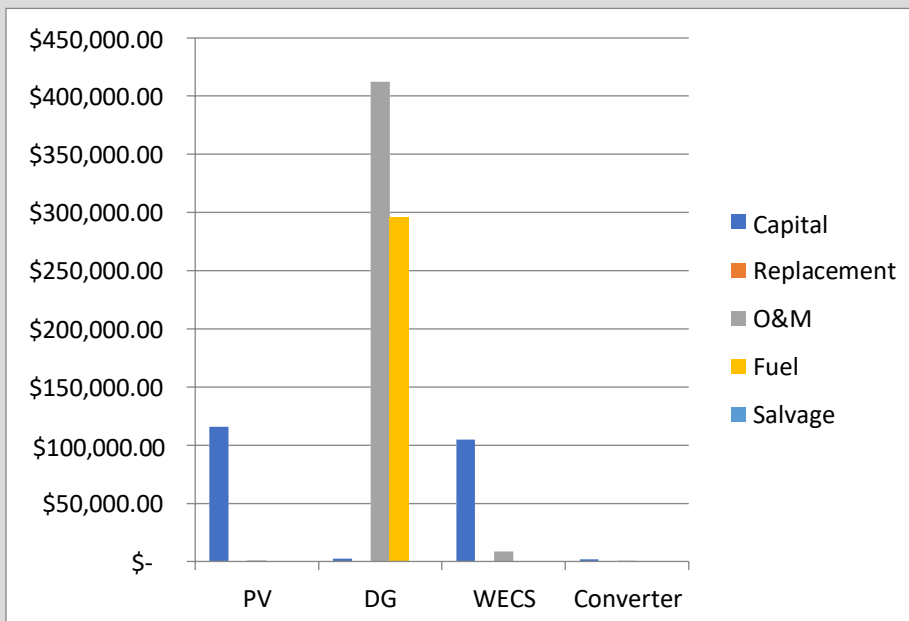

Figure 50: The detailed NPC costs of each component in the system.

The Annualized cost categorized by hybrid system component is shown in Fig.51.

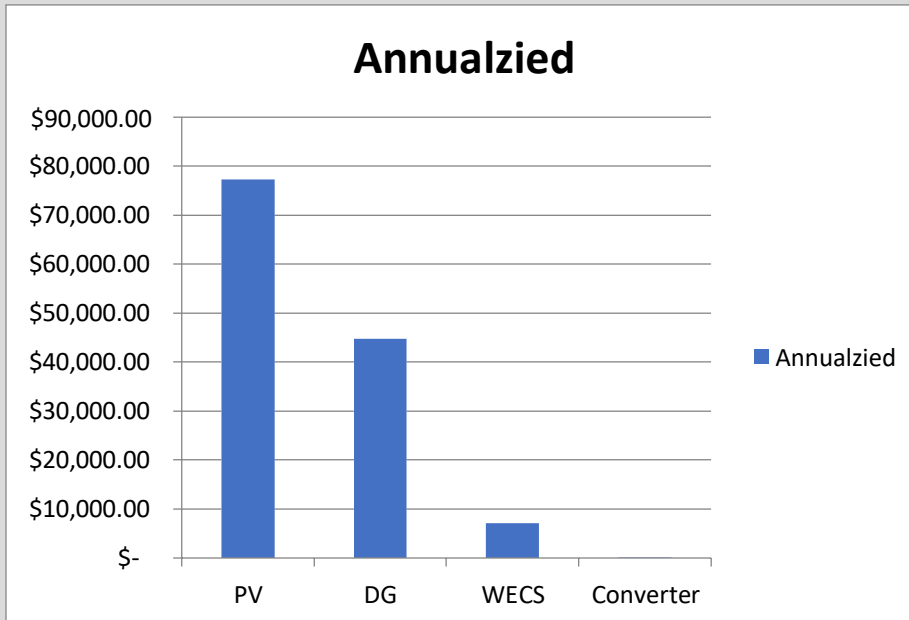

Figure 51: The annualized cost of each component of the hybrid system.

Fig.52 reviews the annualized cash flow for each component of the hybrid system. The highest initial investment cost for PV and the highest O&M cost of DG.

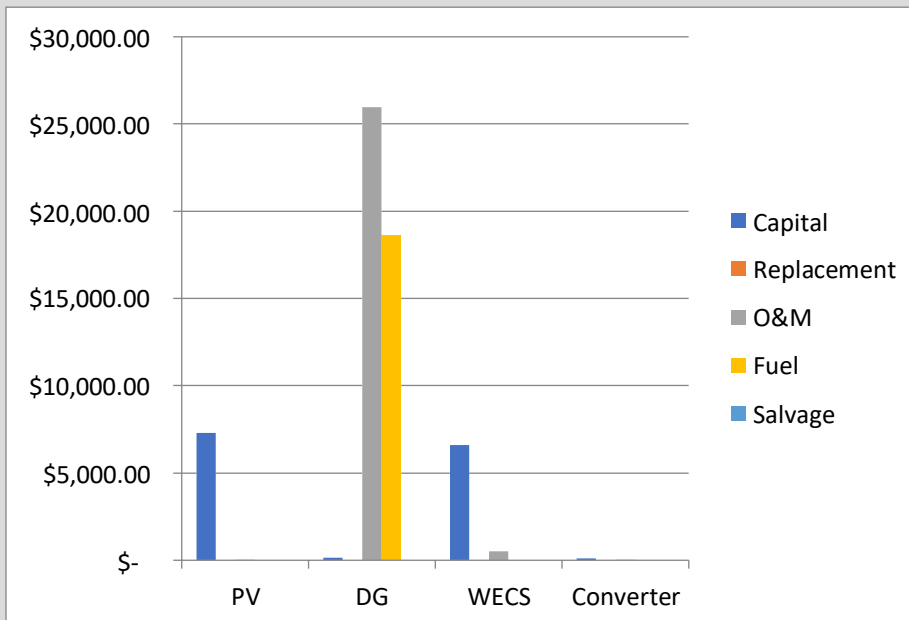

Figure 52: The detailed annualized cost of each component of the hybrid system.

The Pw of this configuration is \$0, the Aw is 0\$/yr and the ROR percentage 0%.

The results shows that the optimum design of the off-grid hybrid energy system which consists of PVESC/WECS/BESS with DG it is the most economic one, since it has the lowest NPC 150,882\$ and COE 0.141\$/kWh. But, the COE approximately must be lower it makes the configuration better. It also has the highest present worth of 39,650\$ and the annual revenues of 3714\$/yr. About the ROR it is 17.1% which greater than the internal rate of return 16.7%. The SPP is 5.8yrs compared with the life time of the project it is good period. The DPP is 6.7yrs. These results show that configuration is feasible compared with the rest.

It has the largest electricity production. The contribution of the DG is weak, since the renewable energy fraction 99.6%.

The contribution of the WECS is more than the PVESC in producing electricity.

Because of the poor contribution of the DG in producing electricity the values of emitted emissions are very low which means it is also environmentally friendly.

The present worth (21,526\$) of the second one shows that the configuration not feasible.

Also, the present worth of the next one is minus which means that the last configurations will lose.

About the optimization results of the on-grid hybrid system, it shows that the PVESC, WECS, DG with connected grid is the most economic. Since it has the lowest NPC of 135,572\$ and operating cost 4360\$. The COE produced 0.0495\$/kWh is also low. It also has the highest present worth of 120,367\$ and the annual revenues of 11,276\$/yr. The ROR it is 35.1% and the internal rate of return 35.1%. The SPP is 2.8yrs compared with the life time of the project it is good period. The DPP is 3.07yrs. These results show that configuration is feasible compared with the rest. The salvage value is zero for all components.

It has the largest electricity production, from PV about 28,524kWh, 125,503kWh from WCES and 20,955kWh from grid. The amount of the energy sold greater than the purchased. The contribution of the DG is zero. The renewable energy fraction is 87.8%.

The contribution of the WECS is more than the PVESC and grid in producing electricity.

The excess electricity among the year 1276kWh, it is a relatively low amount that means there is no high amount of lost energy. The unmet electrical load is 0.

Because of the poor contribution of the DG in producing electricity the values of emitted emissions are very low which means it is also environmentally friendly. The converter operates just as inverter.

In the second configuration, the NPC is higher than the first one, the operating cost and the COE of 0.05\$/kWh. The contribution of the converter is zero, because of the absence of the PV system.

The present worth is less than the previous one is 107,751\$, it has a highest ROR of 45.1%. The SPP is 2yrs. The contribution of the WCES is more than the grid. It has no excess electricity.

The third configuration is still a bit feasible, it has 66,936\$ present worth and the ROR 25.8%. But the COE is 0.148\$/kWh. The excess electricity is 7680kWh/yr.

The last configuration has a highest NPC of 255,939\$ and COE of 0.239\$.

After implementation the two scenarios on the WWTP, the comparison between them will be doing:

The on-grid system has a lowest NPC, lowest COE, highest present worth, highest annual revenues, highest ROR, lowest SPP and lowest DPP, that means that the on-grid system is more optimum than the off-grid system.

## **Chapter 8: Conclusion.**

The process of generation electricity by hybrid energy system is complex since the system dealing with variables and non-linear relations, so the HOMER pro software was a good practice solution to deal with such these problems. HOMER software can do the design; simulation and optimization to get the best optimum design that will serve and cover the load demand.

After many simulations for both the off-grid and on-grid hybrid energy systems.

The off-grid hybrid system which consists of PVECS, WCES, BESS with DG was the most economic one. It includes PVESC with 33.8kW, 4WECSs, 124batteries and 21.3kW converter capacity.

The COE, NPC, initial capital and O&M are 0.141\$/kW, \$150,882 and \$142,037, respectively. The present worth and annual worth are 39,650\$ and 3714\$, respectively. The SPP is 5.8yrs.

The WECS and BESS with DG system. It includes 9WECS, 232 batteries, DG of 45kW and 46.6kW converter capacity. The COE produced by this configuration is 0.409\$/kW. The present worth and annual worth are (\$21,526) and (\$2017), respectively. The SPP is 10yr. This is not feasible.

The last two configurations are not feasible, too.

The on-grid hybrid system which consists of PVECS, WCES, Grid with DG was the most economic. It includes PVESC with 16.3kW, 4WECSs, 10kW DG and 10.8kW converter capacity.

The COE, NPC, initial capital and O&M are 0.0495\$/kW, \$135,572 and \$66,340, respectively. The present worth and annual worth are 120,367\$ and 11,276\$, respectively. The SPP is 2.8yrs.

The second and third configurations are still feasible, according to the obtained results.

The last one is a bit feasible since the value of the present worth is zero, which means there is no revenues, the project will recover only the initial capital cost.

At last, the optimum design according to the implemented comparison between the optimum designs of the off-grid and on grid systems is the on-grid system which consists of PVECS, WCES, and BESS with DG. It has the lowest NPC, lowest COE, highest present worth, highest annual revenues, highest ROR, lowest SPP and lowest DPP.

## References:

(ERC), E. R. (2020). *An-Najah National University*. .

Ahmed, H. A. (2016). A review of optimum Sizing of hybrid PV-Wind renewable energy system in Oman. 53.

Ahmed, N. A. (2012). On-grid hybrid wind/photovoltaic/fuel cell energy system. Ho Chi Minh, Vietnam.: IEEE.

Engineering, E. S. (2019). Off-grid hybrid renewable energy system for rural healthcare centers: A case study in Nigeria. 7(3).

Engineering, E. S. (2019). Off-grid hybrid renewable energy system for rural healthcare centers: A case study in Nigeria. 7(3).

Hollands, V. A. (1999). A method to generate synthetic hourly solar radiation globally. *Solar Energy* , 333-341.

Milhem, H. Z. (2020). Paving the Way for a Renewable Energy Future in Palestine. *This week in Palestine*. .

Moniure, S. (2012). Cost analysis of PV/Wind/diesel/grid coconnected hybrid systems.

Okinawa Enetech Co, I. (2016). *Homer Software*.

Optimization Design of a Stand-alone Hybrid Energy System for a Remote Village in Palestinain Territories2017ENGINEERING RESEARCH AND TECHNOLOGY 4273-82

Shawon MJ, E. L. (2013). Overview of wind energy and its cost in the Middle East. . *Sustain Energy Technol Assess*.