

An-Najah National University



Faculty of Engineering and Information Technology

Computer Engineering Department

Graduation Project II

“Wire Wizard”

Prepared by:

Leen Shaikh Ibrahim & Raghad Deraweh

Supervised by:

Dr. Raed Qadi

**Presented in partial fulfillment of the requirements for
bachelor’s degree in computer engineering.**

Acknowledgment

Foremost, our gratitude is extended to the divine for bestowing blessings upon us and entrusting us with the execution of this endeavor.

Unwavering appreciation is owed to our families for their unceasing support and unwavering encouragement, which has been a steady companion from inception to culmination. Recognition is also owed to Dr. Raed Qadi for his assistance and provision that proved instrumental in bringing this project to fruition.

Our esteemed faculty members in the Department of Computer Engineering merit profound thanks. Their guidance and contributions have been pivotal in nurturing our growth, and as we stand at this juncture, their influence is deeply acknowledged and cherished.

To the countless others who have stood by us through every challenge, our heartfelt gratitude flows abundantly. It is with immense appreciation that we present this report and project as a testament to your unwavering support and belief in us

Disclaimer

Leen Shaikh Ibrahim and Raghad Deraweh are the authors of this document, originating from the Computer Engineering Department within the Faculty of Engineering at An-Najah National University. The content has remained unaltered, save for editorial refinements, due to the evaluation process, and as such, it might encompass linguistic or substantive inaccuracies. The viewpoints presented, including any ensuing results and suggestions, exclusively belong to the students. An-Najah National University disclaims any responsibility or accountability for potential repercussions arising from the utilization of this report for objectives beyond its originally intended scope.

Table of contents

Acknowledgment	2
Disclaimer	2
Table of contents	3
Table of Figures	4
Abstract	5
Report Organization	5
Chapter 1: Introduction	6
1.1: Statement of the problem	6
1.2: Objectives and Scope	6
Chapter 2. Constraints and Earlier Coursework	7
2.1: Constraints	7
2.2: Earlier Coursework	8
Chapter 3. Literature review	9
Chapter 4. Methodology	10
4.1 Hardware Content	10
4.2 Mechanical Part	16
4.3 Touch Screen	16
Chapter 5. Results and Discussions	21
5.1 Testing	21
Conclusion and Recommendations	22
References	24

Table of Figures

- Fig (1): Block Diagram..... 10
- Fig (2): ESP32..... 10
- Fig (3): Stepper Motor 11
- Fig (4): A4988 Driver 11
- Fig (5): IR Optocoupler..... 12
- Fig (6): Hall Effect Sensor 12
- Fig (7): Limit Switch 13
- Fig (8): Voltage Regulator13
- Fig (9): Arduino Mega 2560 14
- Fig (10): Power Supply 14
- Fig (11): Nextion HMI15
- Fig (12): Wiring Design 15
- Fig (13): Rods, bolts, screws, nuts and wire cutter 16
- Fig (14): Screen 1 17
- Fig (15): Screen 2 17
- Fig (16): Screen 3 18
- Fig (17): Screen 4 18
- Fig (18): Screen 5 19
- Fig (19): Screen 6..... 19
- Fig (20): Screen 7 20
- Fig (21): Screen 8 20

Abstract

Wire customization and manipulation are integral to various industries, but the process often involves intricate calculations and manual labor. The "Wire Wizard Machine" offers an innovative solution to these challenges by integrating automation and user-friendly controls. This project introduces a versatile system that simplifies inductor creation, wire stripping, and the utilization of spring wires. The Wire Wizard Machine's features provide a seamless way for users to customize wires and inductors to their requirements.

Features included in the project:

- **Wire Mode:** Users can specify wire length, choose stripping preferences (right, left, both, or none), and select wire curvature (straight or spring). The machine executes these actions, delivering customized wires with precision.
- **Inductor Mode:** Users have the option to input the desired number of wire rolls directly or provide values for inductance (L) and wire diameter. The machine calculates the required roll numbers, streamlining the creation of customized inductors.

Report Organization

- **First chapter:** In this chapter, we will go through the introduction of the project including the problem statement, objectives, scope and significance of the project.
- **Second chapter:** We will list the constraints we faced and mention earlier coursework that proved to be helpful during the work on this project.
- **Third chapter:** We will briefly discuss the areas our project covers and some information about how these areas relate to the project in other papers.
- **Fourth chapter:** In this chapter, we will go into details of how the project works including all the algorithms and hardware parts and tools we used.
- **Fifth and final chapter:** We will show the contribution of this project and discuss the results

Chapter 1: Introduction

1.1: Statement of the problem

Wire handling is pivotal across industries, including electronics and manufacturing. However, existing methods for crafting inductors, precise wire stripping, and spring wire utilization are labor-intensive, error-prone, and lack modern precision. Traditional techniques fall short of industry demands, leading to inefficiencies, waste, and inaccuracies in wire management.

Creating inductors is intricate, demanding complex calculations for roll counts and accommodating user preferences for wire curvature and stripping. These challenges impede productivity, elevate costs, and compromise wire quality, adversely affecting device performance.

An automated and user-friendly solution is urgently needed to optimize wire customization, simplify inductor fabrication, and ensure precise wire stripping. Addressing these needs, the "Wire Wizard Machine" project strives to transform wire preparation. By minimizing manual intervention, reducing errors, and enabling tailored wires, it aspires to reshape wire-handling practices in the electronics and technology sectors.

This project's core objective is to engineer an automated system that bolsters wire handling's efficiency, and customization capabilities. With reduced manual involvement, minimized errors, the Wire Wizard Machine sets out to redefine wire preparation methodologies and enhance industrial processes across sectors.

1.2: Objectives and Scope

The project aims to develop an automated system that streamlines wire customization processes, simplifies inductor fabrication, and ensures precise wire stripping. The scope encompasses designing an intuitive Nextion HMI interface, integrating calculations for inductor roll counts, and enabling wire curvature and stripping preferences. The goal is to enhance wire handling efficiency and accuracy, benefiting industries relying on customized wire solutions and inductor creation.

Chapter 2. Constraints and Earlier Coursework

2.1: Constraints

2.1.1 Timeline Constraint

The project is bound by a precise schedule, exacerbated by the brevity of the summer semester and unforeseen disruptions that further compressed the implementation phase. This tight timeframe posed a significant challenge throughout the project's development.

2.1.2 Budget

The project's financial resources are limited, which necessitates cost-effective design choices and procurement of components within the allocated budget.

2.1.3 Technical Expertise

The team's expertise is centered on the fields of engineering and software development; therefore, constraints may arise when addressing complex mechanical or specialized electrical engineering challenges.

2.1.4 Low quality of some parts

To minimize expenses, we opted for pre-owned parts, like repurposing stepper motors from a discarded printer. However, this decision compromised the overall effectiveness and quality of certain components due to their suboptimal condition.

2.1.5 Navigating Mechanical Challenges

Our project's mechanical components exposed our team's limited expertise in this area. Overcoming challenges in designing the wire handling mechanism and shape-altering module was complicated due to our software-centric background. Procuring wires that met project criteria, especially with specific dimensions, proved intricate. Resorting to a 3D printer helped fabricate tailored components.

2.2: Earlier Coursework

2.2.1 Microcontrollers and PIC

All the basics of the Raspberry, Arduino, ESP32 like I/O and basic serial communication were taken in these courses.

2.2.2 Networks and Communication

We implemented the knowledge from this course in many aspects, like setting up an ssh connection with the Raspberry Pi to control it from a laptop, we also needed the knowledge to manage the connection between the Raspberry Pi and the Arduino and ESP32 modules using wifi protocols.

2.2.3 Critical Thinking and Research Skills

The research and the writing of this report was done using the knowledge gained from this course.

2.2.4 Electronic circuit's courses

These courses highly contributed in dealing with different modules and finding the right power sources and connection for each of them.

2.2.5 Programming courses

Mainly C++ and OOP for writing the codes and algorithms.

Chapter 3. Literature review

The Wire Wizard Machine project resides at the intersection of wire customization, automation, and mechanical engineering. This literature review surveys relevant research, technologies, and methodologies in these domains, providing essential context for the development of our project.

Proposing the employment of spring-wire turbulator for flat spiral tubes utilized in solar ponds, experimental study

This paper by Aldawi investigates the application of spring-wire turbulators to improve heat transfer efficiency in curved tubes, presenting findings on enhanced heat transfer rates and associated pressure drop considerations. This paper is directly relevant to the "Wire Wizard" project, as it explores innovative wire-based heat transfer enhancement techniques within curved tubes, providing valuable insights that can inform the design and implementation of wire-based enhancements in your project, aiming to optimize heat transfer efficiency in curved tube heat exchangers.

Improved staggered through silicon via inductors for RF and power applications

This paper explores advanced techniques for optimizing inductor performance, with a particular focus on 3D through silicon via (TSV) inductors. These techniques include using polymer walls as shielding, staggered TSV configurations, and the incorporation of magnetic cores and airgaps to enhance inductance and quality factors. The relevance of this paper to the Wire Wizard project lies in its insights into inductor design and optimization. Since inductors play a crucial role in wire-related systems, understanding these advanced techniques can aid in improving the performance of our Wire Wizard project, especially in terms of minimizing electromagnetic interference, increasing inductance density, and enhancing overall wire system efficiency.

Chapter 4. Methodology

Initially, our learning process involved comprehending the distinct attributes of each component, including its operational characteristics, pin functionalities, and interfacing requirements with ESP. Subsequently, we embarked on individual programming endeavors for each component, tailoring their functions to align with the overarching system requisites. Culminating this phase, we seamlessly integrated all components into a cohesive configuration, finalizing the establishment of the complete system.

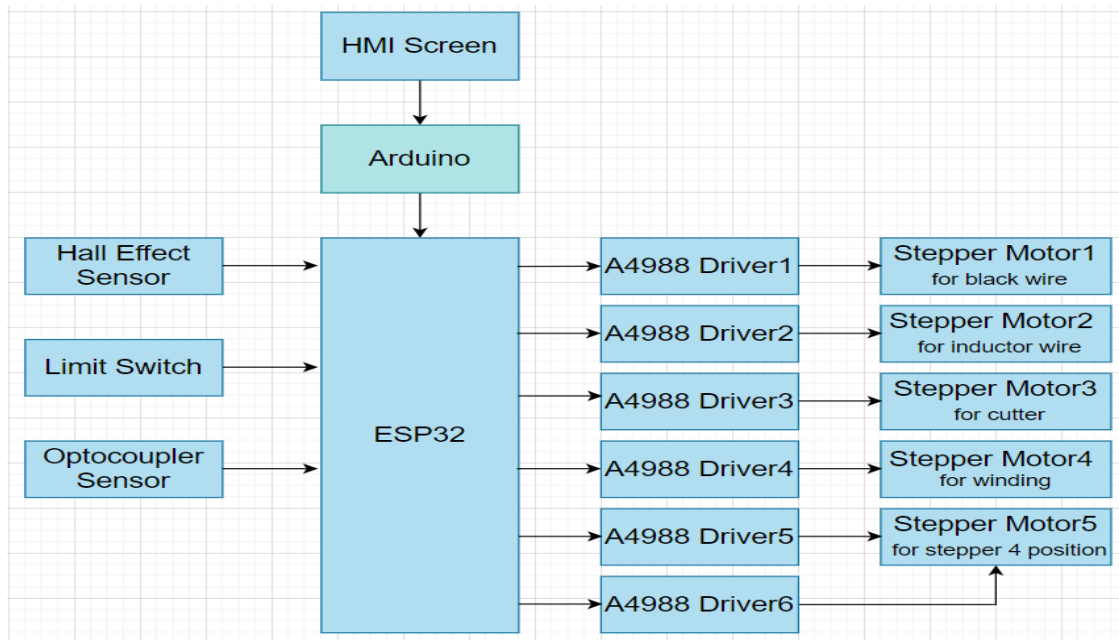

Fig (1): Block Diagram

4.1 Hardware Components

4.1.1 ESP32

ESP32 is a low-cost System on Chip (SoC) Microcontroller from Espressif Systems, the developers of the ESP8266 SoC. It enables microcontrollers to connect to 2.4 GHz Wi-Fi.



Fig (2): ESP32

4.1.2 Stepper motors, Nema17 and Nema23

A stepper motor, also known as step motor or stepping motor, is a brushless DC electric motor that divides a full rotation into a number of equal steps. In our project, we incorporated five stepper motors into our system. Specifically, we utilized four Nema 17 type stepper motors for various purposes: one to control the movement of the regular wire, another to handle the inductor wire, a third to facilitate the wire winding process, and the fourth to manage the motor responsible for wire winding. Additionally, we employed a Nema 23 type stepper motor for cutting and stripping operations.

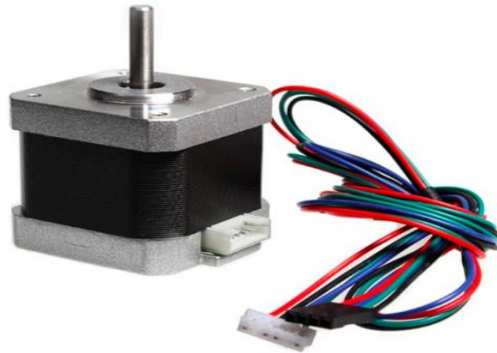

Fig (3): Stepper Motor

4.1.3 A4988 driver

Given the presence of five stepper motors in our setup, a single driver was allocated for each NEMA17 motor, while the NEMA23 motor was allocated two drivers. This aggregation results in a cumulative count of six drivers. This strategic allocation affords me comprehensive control.

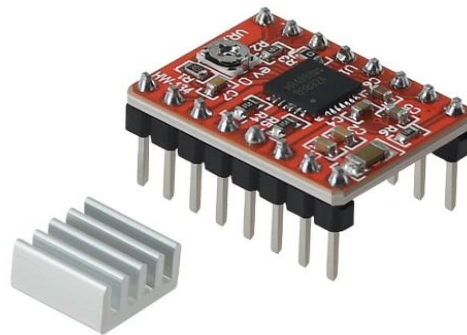

Fig (4): A4988 driver

4.1.4 IR Optocoupler Sensor

An optocoupler sensor uses light to transfer signals between isolated circuits, ensuring electrical separation. So we used it to be responsible for determining the initial position of the metal rod before initiating the winding process.

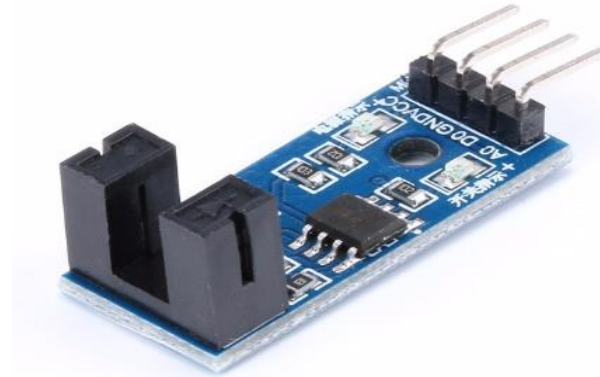

Fig (5): IR Optocoupler

4.1.5 Hall Effect Sensor

A Hall effect sensor detects magnetic fields and converts them into electrical signals, making it useful in applications like position sensing and current measurement. So we used it to be responsible for accurately identifying the initial position of the cutter.

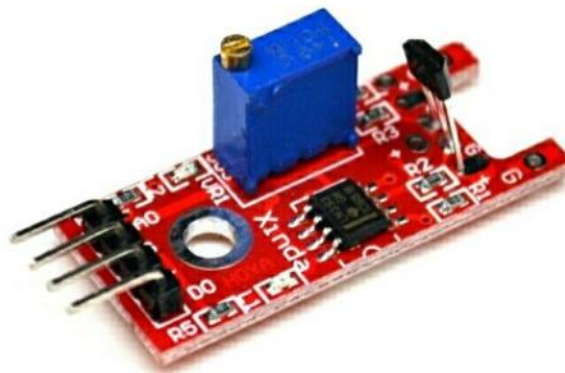

Fig (6): Hall Effect Sensor

4.1.6 Limit Switch

Is a mechanical device that senses the presence or absence of an object, often used to control machinery or as an end-stop in automation systems. It functions by physically contacting the object to trigger an electrical response, signaling the limits of motion. We used it to determine the starting point of the motor responsible for winding the wire.

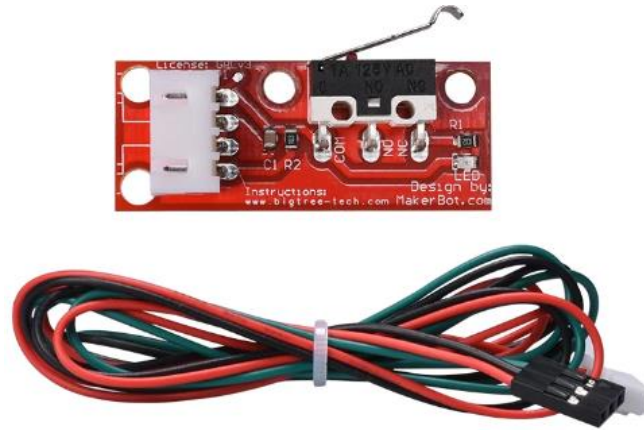

Fig (7): Limit Switch

4.1.7 Voltage Regulator

Is an electronic device that maintains a steady 5-volt output voltage from an unstable input voltage source, ensuring a consistent power supply for various electronic components and devices.

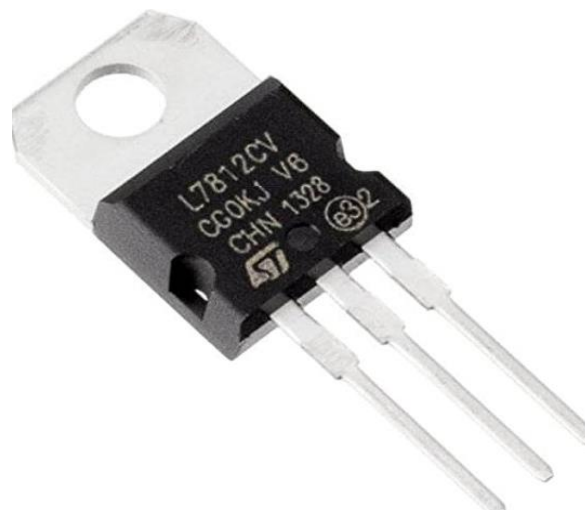

Fig (8): Voltage Regulator

4.1.8 Arduino Mega 2560

The Arduino Mega is a microcontroller board based on the ATmega2560, known for its extensive I/O capabilities and suitability for complex projects. It offers 54 digital I/O pins, 16 analog inputs, and a wide range of connectivity options, making it ideal for advanced electronics and robotics applications. We used it to transfer data from the screen to the ESP device



Fig (9): Arduino Mega

4.1.9 Power Supply (12 volt DC, 10 Amp)



Fig (10): Power Supply

4.1.10 Nextion HMI 3.5 inch

Is a user-friendly touch display designed for seamless integration into various electronic projects. It simplifies the development of interactive graphical user interfaces (GUIs) for embedded systems, offering an intuitive way to interact with devices.



Fig (11): Nextion HMI

4.1.11 Soldering board, Capacitors, Connectors, Wires pin headers, electric power button and another components

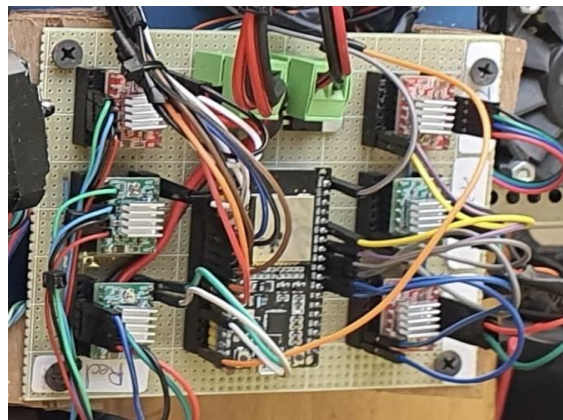

Fig (12): wiring design

4.2 Mechanical Part

This subsection explores the mechanical details and parts that work together to deliver the output to the user.



Fig (13): Rods, bolts, screws, nuts and wire cutter

4.3 Touch Screen

4.3.1 Introduction

We sought a streamlined approach to manage and issue directives to the wire wizard, leading us to implement a touch screen interface for data input. This touch screen encompasses a main page and three secondary pages dedicated to input operations. The creation of these interfaces was facilitated by employing the Nextion Editor tool.

4.3.2 External libraries used

We used the Arduino IDE program and therefore we needed to include the Nextion library.

4.3.3 Description

1. Main page:



Fig (14): Screen 1

This screen is the first screen that appears to the user. When you click on Come on, you will be moved to the second screen.

2. Secondary pages:

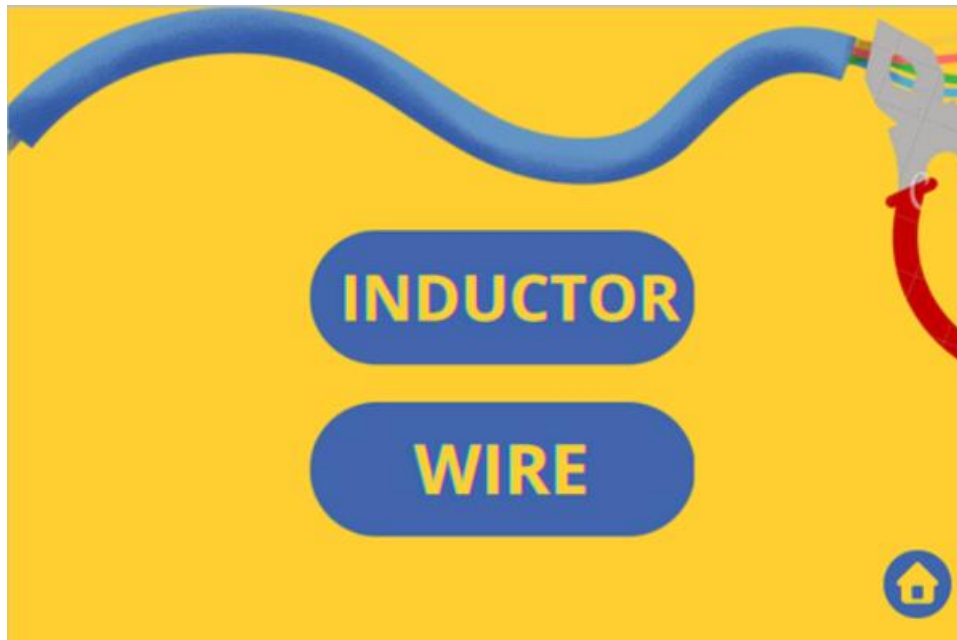

Fig (15): Screen 2

If Inductor Selected:

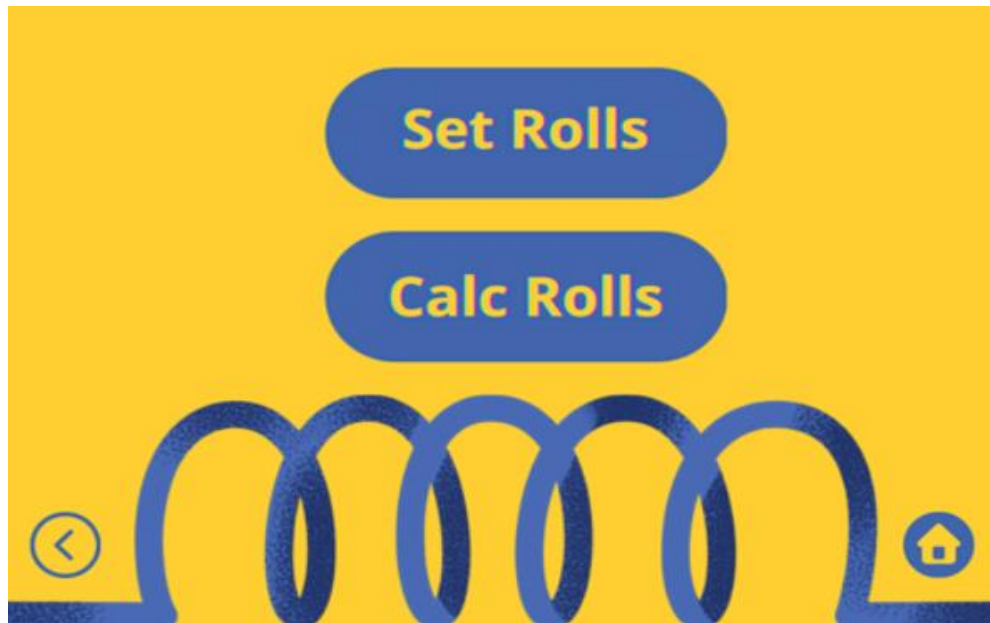

Fig (16): Screen 3

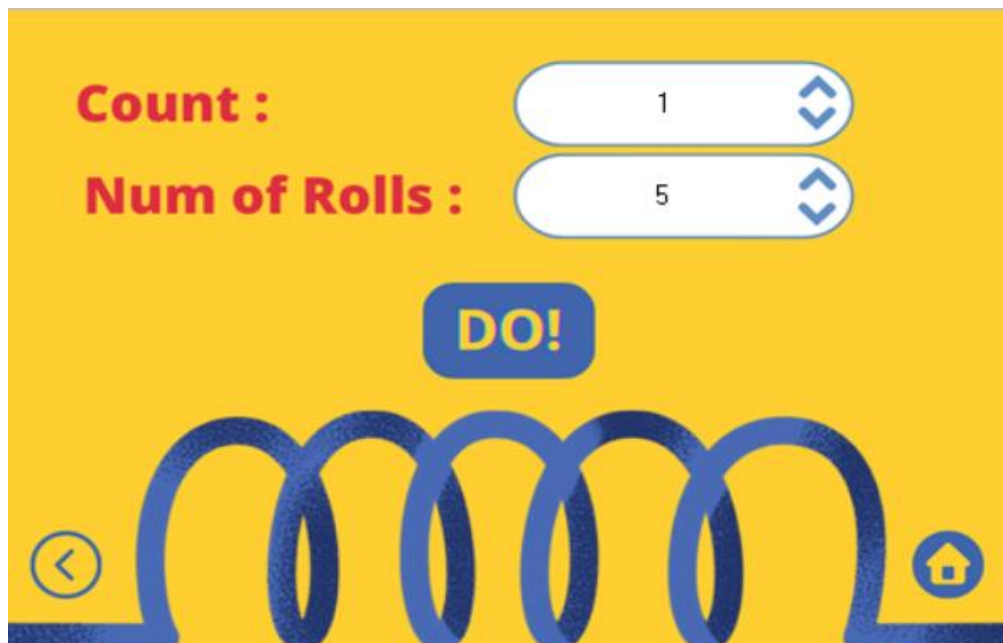

Fig (17): Screen 4

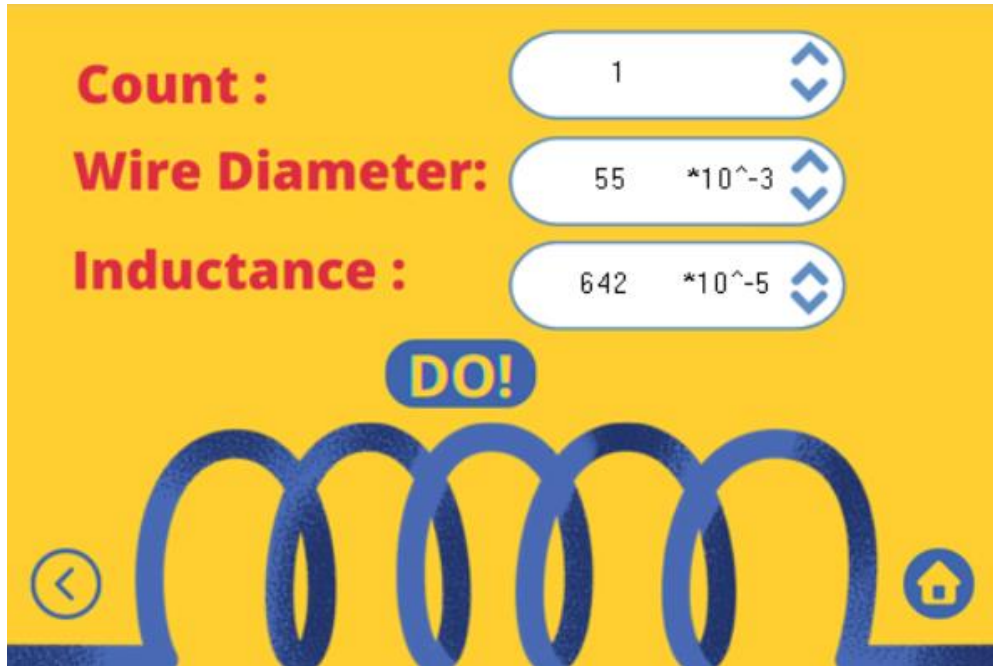

Fig (18): Screen 5

If Wire selected:

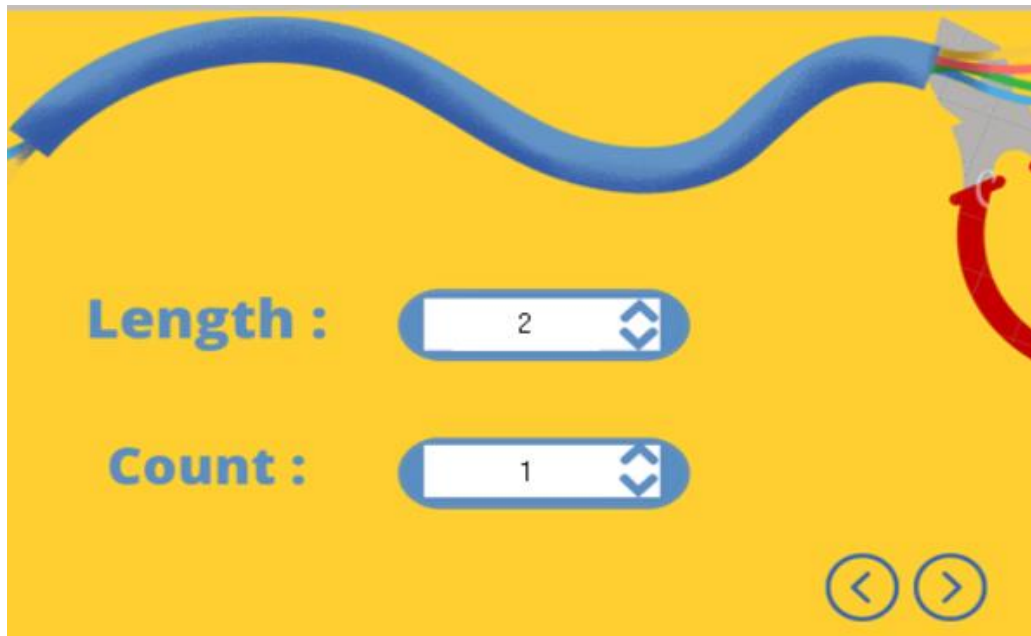

Fig (19): Screen 6

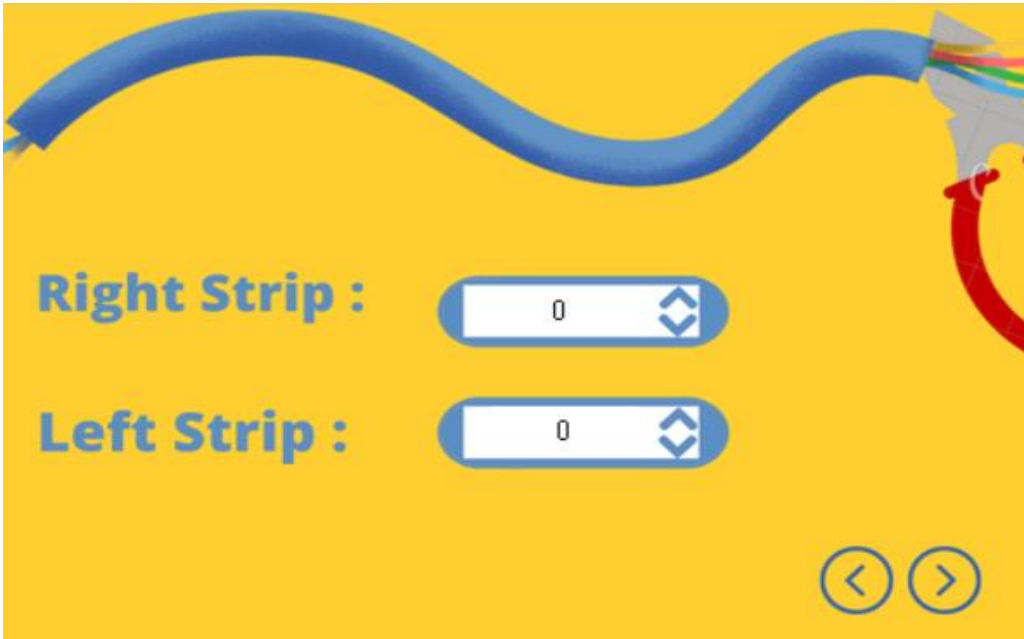

Fig (20): Screen 7

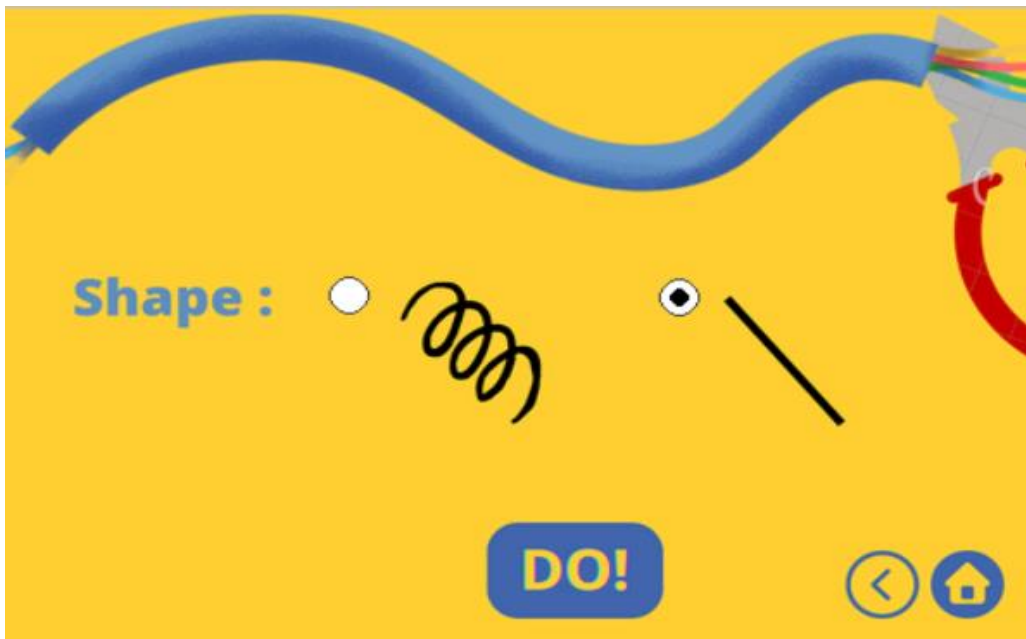

Fig (21): Screen 8

Chapter 5. Results and Discussions

5.1 Testing

The "Wire Wizard Machine" underwent a comprehensive testing process that encompassed its key functionalities related to wire customization, inductor fabrication, and automation. The testing phase focused on validating the system's accuracy, efficiency, and user-friendliness to ensure its successful integration into wire handling processes.

Wire Customization Testing:

Wire Length and Stripping: The system's ability to accurately cut wires to specified lengths and perform stripping actions (right, left, both, or none) was assessed.

Shape Options: The wire shape options, including straight and spring-like shapes, were tested to ensure consistent and precise results.

Inductor Testing:

Direct Roll Input: For the inductor fabrication mode, the accuracy of direct roll input was verified by comparing the machine's calculated results with user inputs.

Inductance Calculation: The accuracy of inductance calculations based on provided wire diameter and other parameters was validated.

User-Friendly Interface:

The Nextion HMI interface was evaluated for its intuitiveness, ease of use, and clarity in guiding users through the customization process.

Feedback Mechanisms:

Users' interactions with the system and their feedback guided iterative improvements and refinements.

The success of the testing phase was determined by the system's ability to consistently produce accurate wire customizations, fabricate inductors with precision, and offer a user-friendly interface. Any identified issues or areas for enhancement informed the refinement process, ensuring that the "Wire Wizard Machine" aligned seamlessly with wire handling and inductor fabrication requirements in various industries.

Conclusion and Recommendations

In conclusion, the "Wire Wizard Machine" project has successfully achieved its primary goal of revolutionizing wire customization, inductor fabrication, and wire handling processes. The integration of automation and user-friendly controls has paved the way for efficient and wire preparation, catering to diverse industries' requirements.

The testing phase affirmed the machine's capabilities, validating its accuracy, efficiency, and user-friendliness across wire customization, inductor fabrication, and automation functionalities. The machine demonstrated its capacity to cut wires to specified lengths, execute various stripping actions, and offer consistent results for wire shapes, whether straight or spring-like.

Additionally, inductor fabrication proved successful, as the machine accurately calculated the required number of wire rolls based on user inputs or inductance values. The incorporation of a user-friendly Nextion HMI interface was pivotal in ensuring intuitive navigation and ease of use, enhancing the overall user experience.

While the "Wire Wizard Machine" marks a significant milestone in wire handling automation, there is room for further enhancement and optimization. Therefore, the following recommendations are suggested for future iterations:

Advanced Motor Technology:

Upgrading to more accurate and efficient motors would enhance the machine's precision and speed, further reducing error rates and improving performance.

Machine Learning Integration:

Incorporating machine learning algorithms for pattern recognition and error correction could lead to even higher accuracy in wire customization and inductor fabrication processes.

Enhanced Sensor Integration:

The addition of advanced sensors for real-time feedback and calibration would contribute to the machine's ability to adjust and adapt to varying wire conditions.

Expanded Wire Compatibility:

Broadening the machine's compatibility with various wire types, diameters, and materials would increase its applicability to a wider range of industries.

User Interface Refinement:

Continuous refinement of the user interface, based on user feedback and usability studies, would further enhance user experience and accessibility.

In conclusion, the "Wire Wizard Machine" project has successfully introduced a transformative solution for wire customization, inductor fabrication, and automation. By addressing wire-handling challenges, the project paves the way for increased efficiency, accuracy, and customization in wire-related tasks across industries. As technology continues to evolve, this sets the stage for ongoing innovation and advancement in wire handling automation.

References

- ArduinoJson: Efficient JSON serialization for embedded C++
<https://arduinojson.org/>
- “Arduino Software.” *Arduino*, <https://www.arduino.cc/en/software>
- “Draw.io to create diagrams.” *diagrams.net*, <https://app.diagrams.net/>
- Proposing the employment of spring-wire turbulator for flat spiral tubes utilized in solar ponds, experimental study by Fayez Aldawi,
<https://www.sciencedirect.com/science/article/pii/S2214157X22004269>
- Improved staggered through silicon via inductors for RF and power applications,
<https://ieeexplore.ieee.org/document/8429767>