



# Underwater Wireless Optical Communication (UWOC)

**By : Hadeel Masri  
Bayan shtaiwi  
Mayson Alawneh**

**Supervisor: Dr. Falah  
Mohammed**



# introduction

Underwater wireless communication refers to transmitting data in unguided water environment through the use of wireless carriers, radio-frequency wave, acoustic wave, and optical wave. We focus, in this thesis, on the underwater wireless optical communication (UWOC) that employs optical wave as the transmission carriers.



## Why Light is Better for Underwater Communication

For short-range, high-speed data transmission (e.g., underwater drones, sensor networks, diver communication, robotic submarines) → Optical (laser) communication is the best choice.

comparison

**RF is generally not** preferred due to its high absorption and impractical antenna sizes.

technique for encoding  
messages

- We used the **Morse Code** technique for encoding messages, where text is converted into sequences of dots and dashes

technique for modulation  
to control the laser signal

- **PWM (Pulse Width Modulation),** PWM provides energy efficiency, reliability, and precise control over the laser signal, making it ideal for transmitting Morse code underwater.
- It ensures clear, noise-resistant, and power-efficient communication, making your system more effective.

# Hardware parts

TX

★ Keyboard



★ USB Host Shield





# Mosfet Circuit

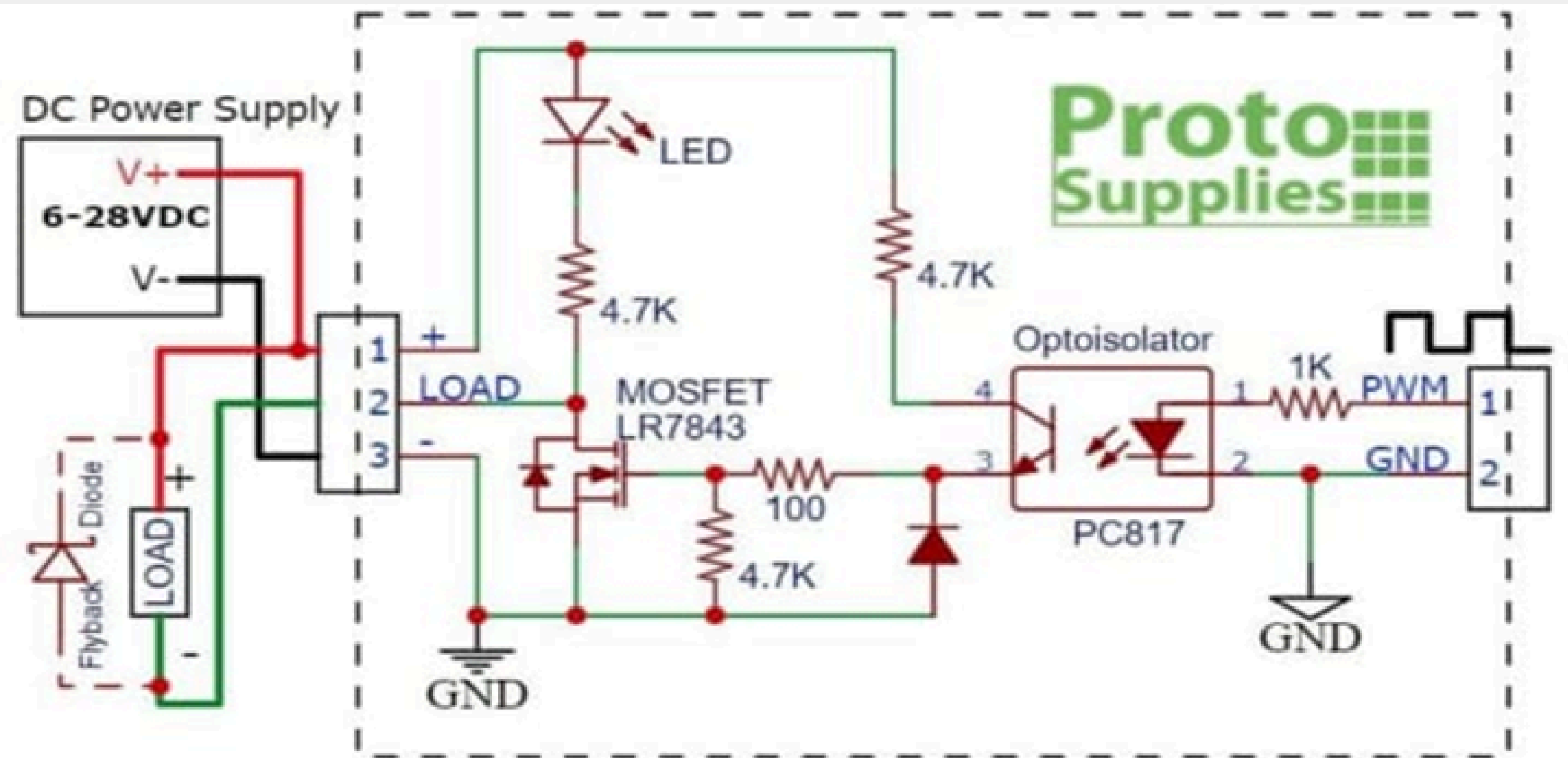
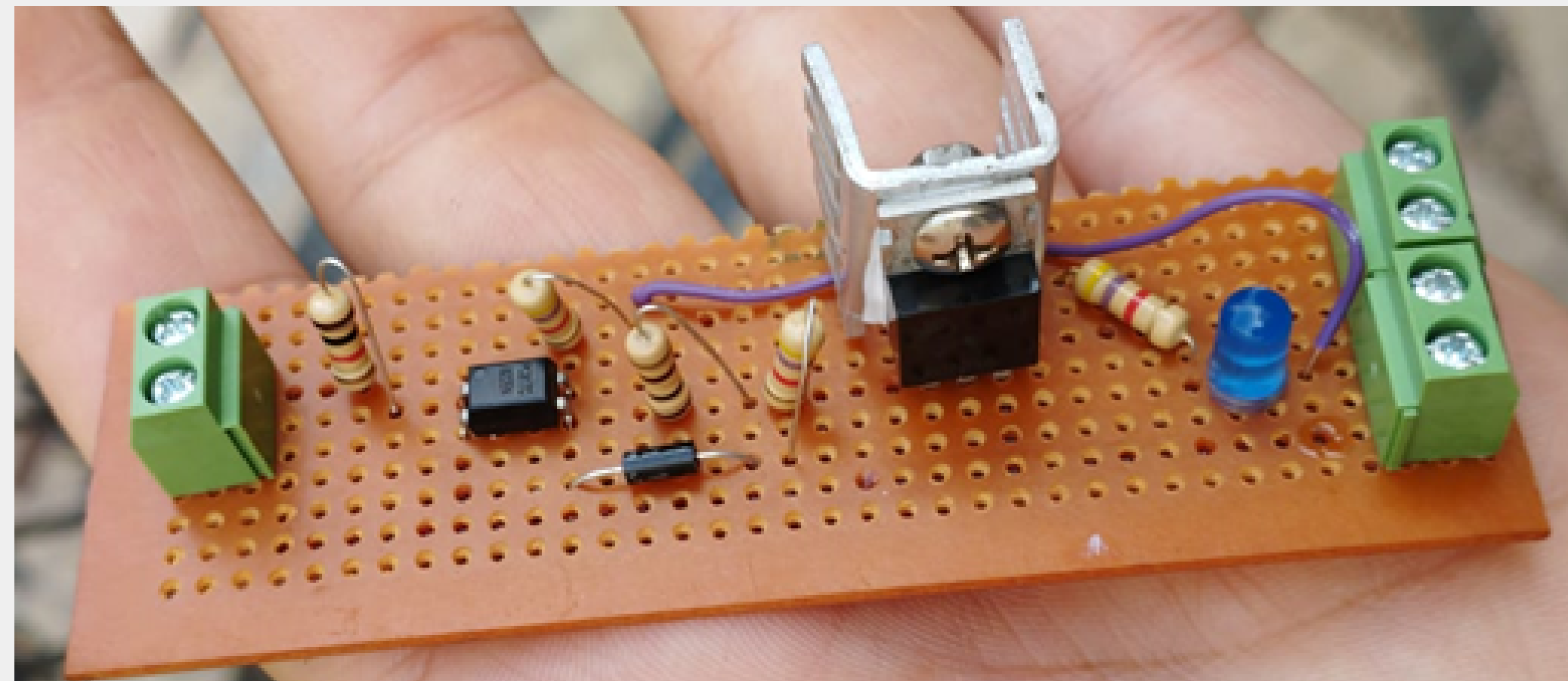



Laser

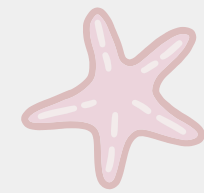

Battery

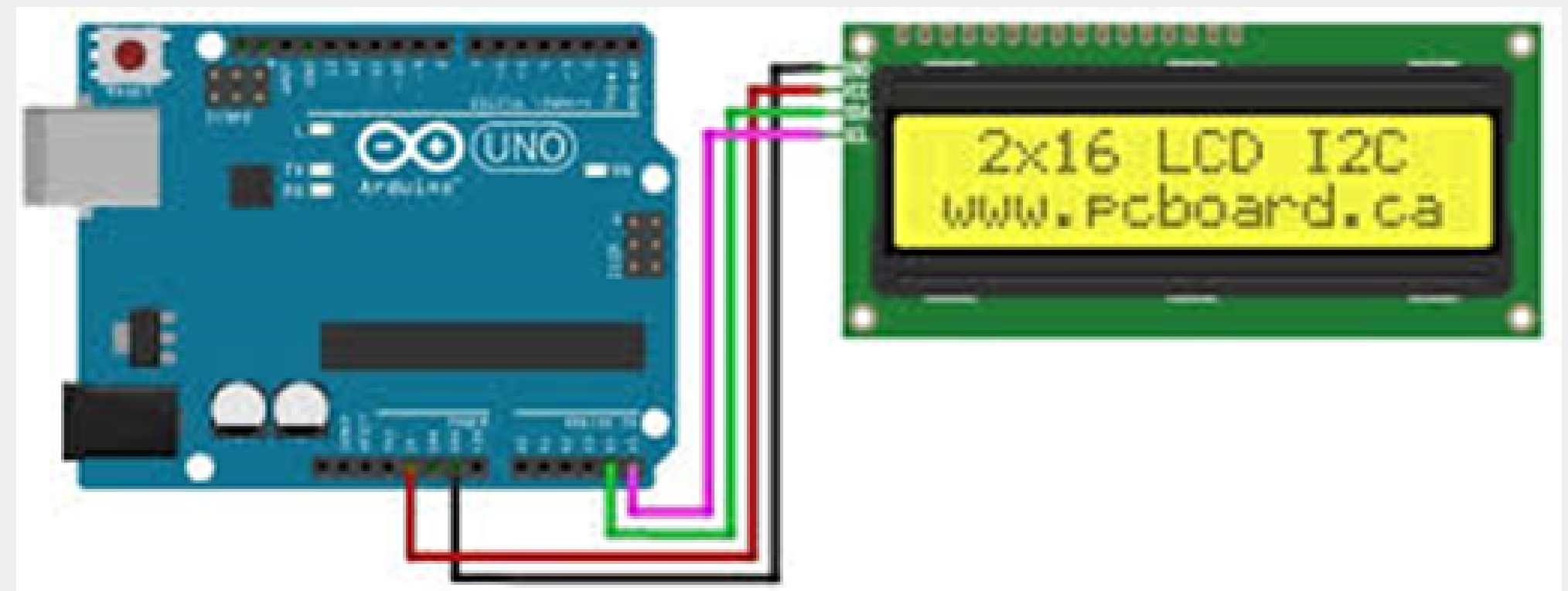

LCD with I2C

RX



Push Button



LDR Sensor

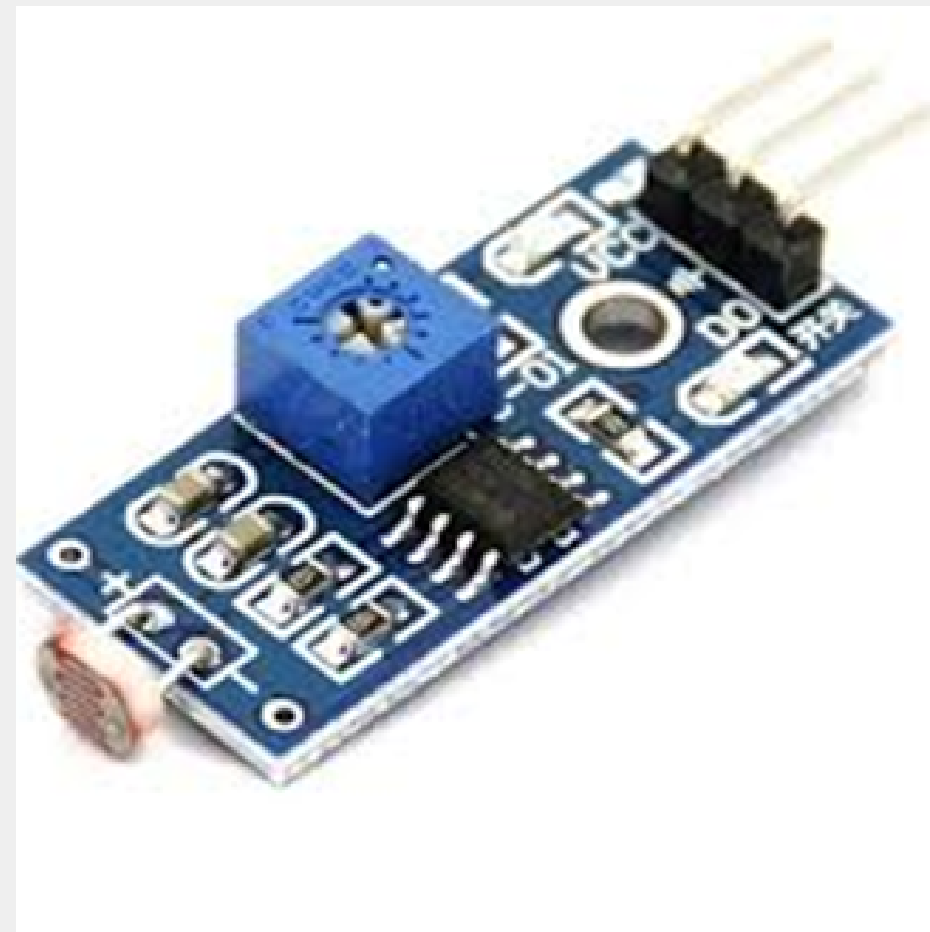



Arduino Nano



LCD with I2C

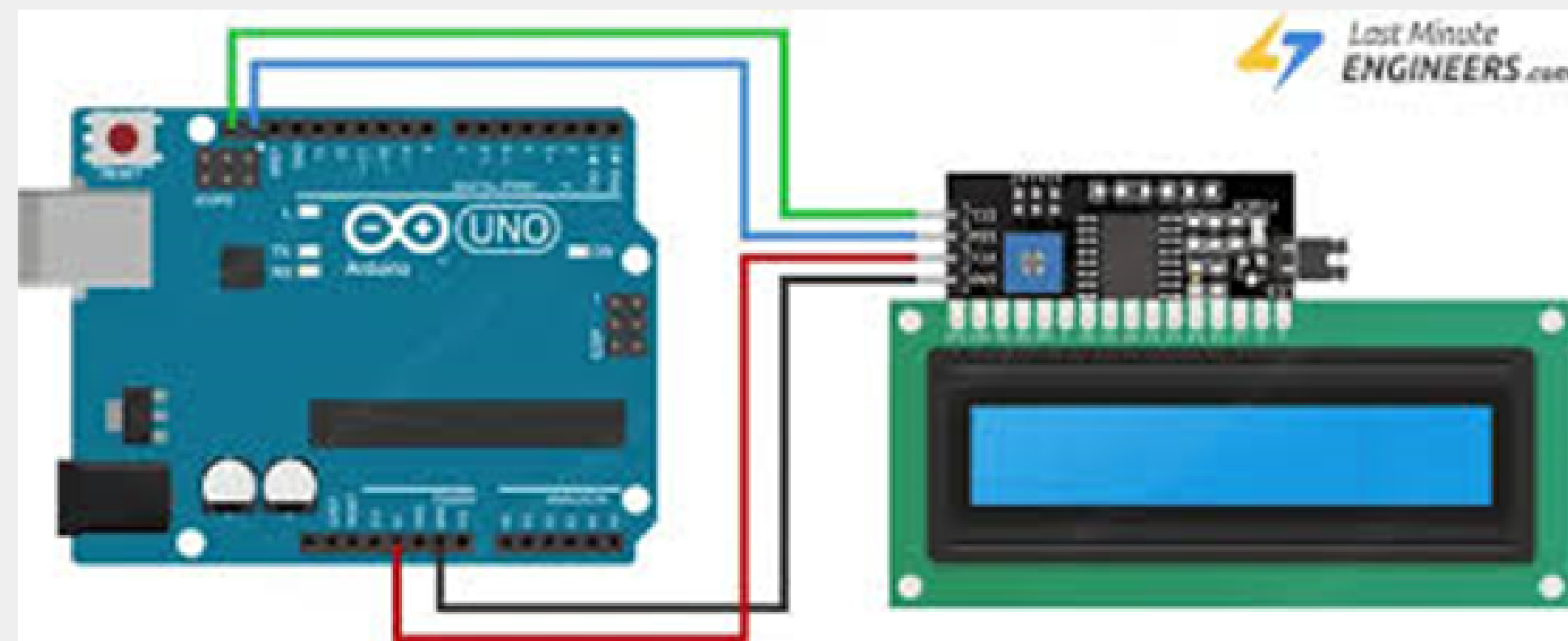

# Block Diagram



## Transmitter

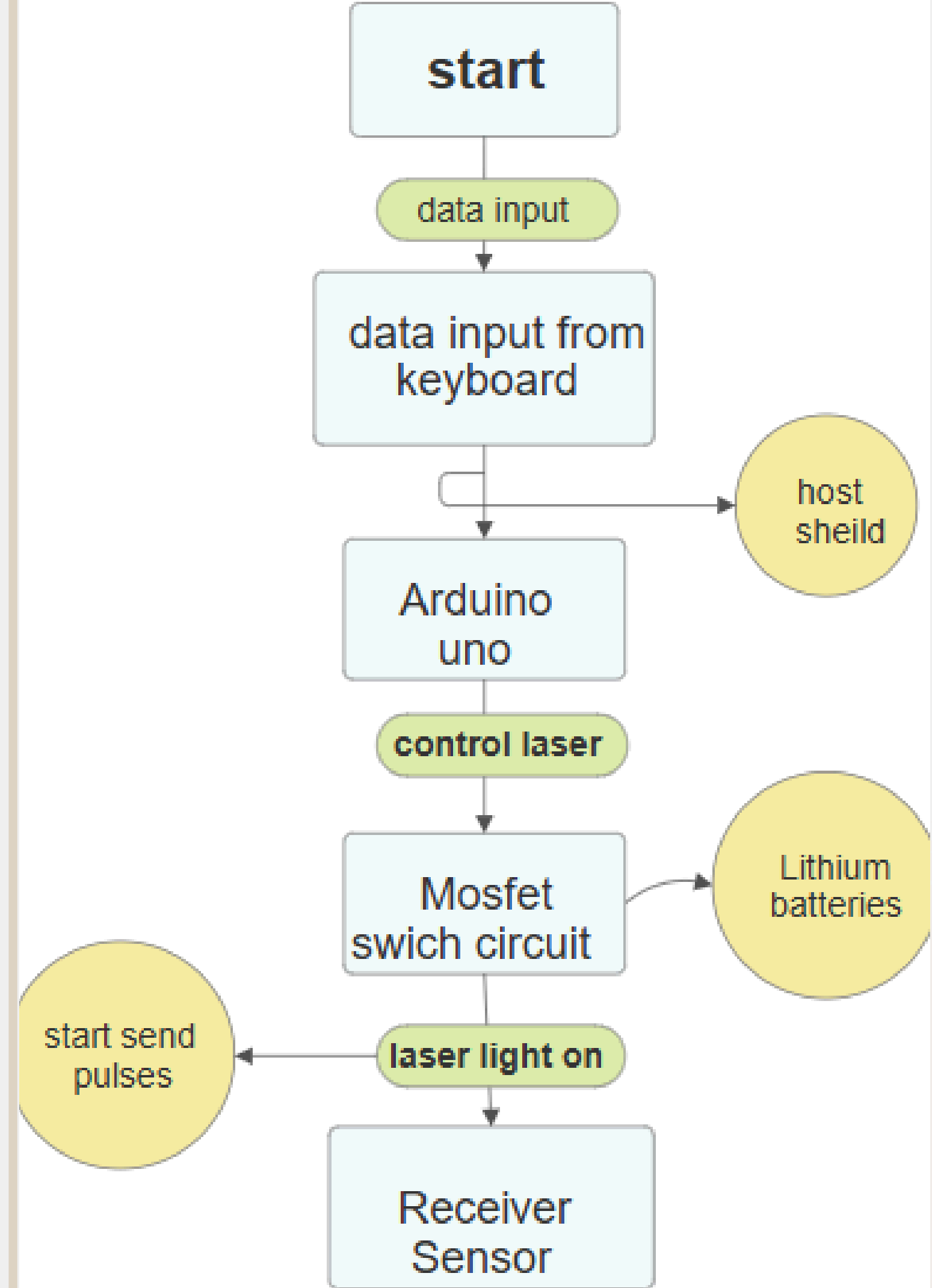

# Block Diagram



Recriver

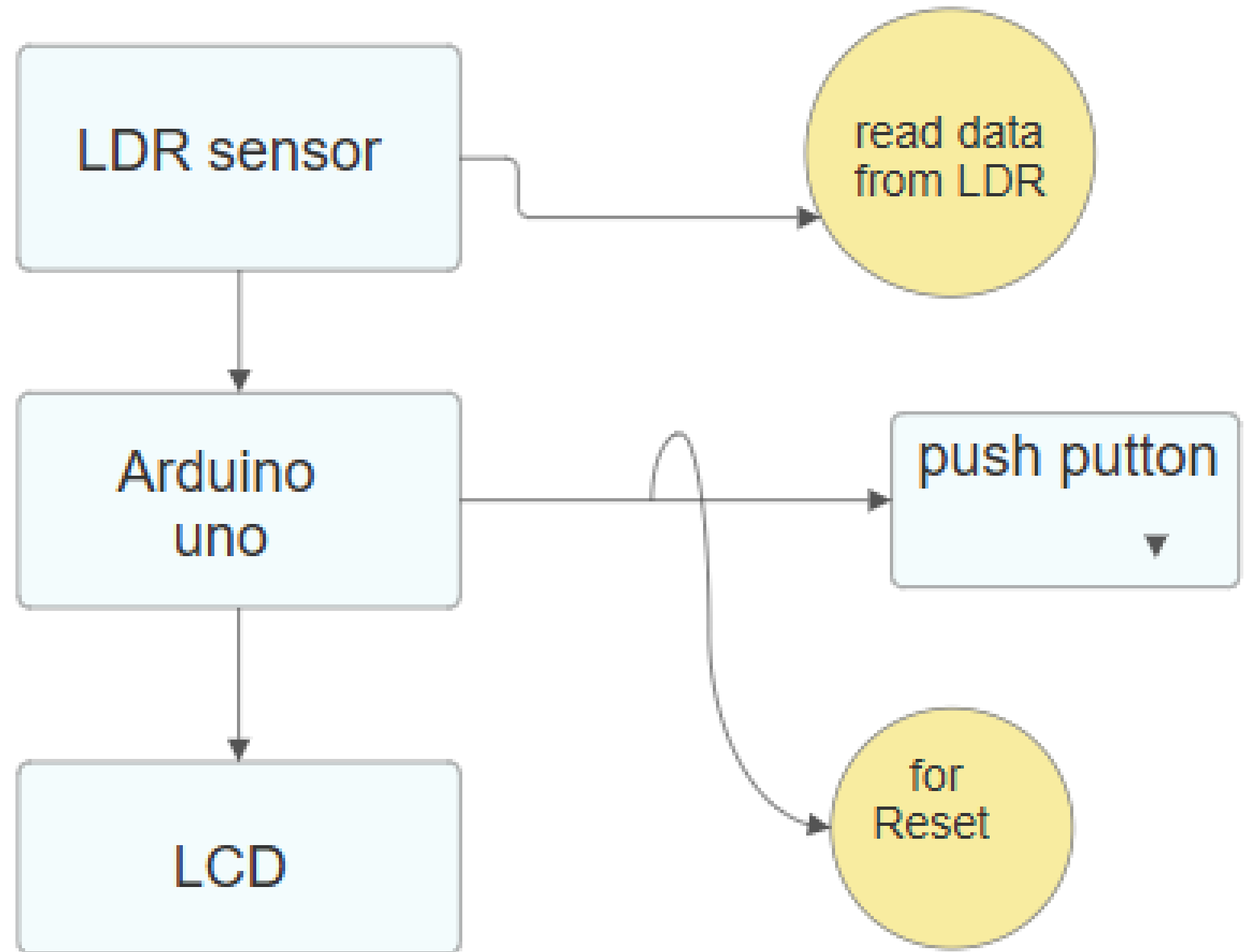

# Water environments used in the experiment





Salt water

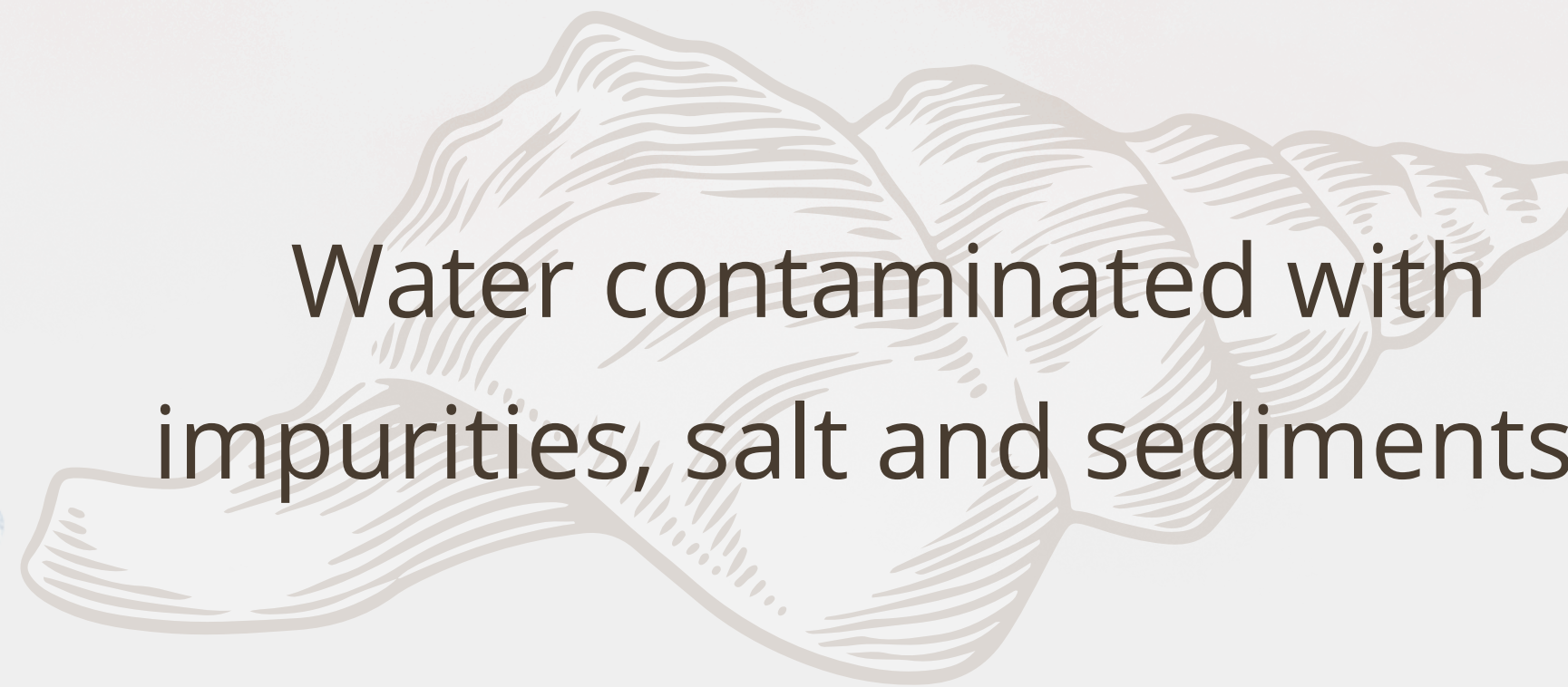

Pure Water



Water contaminated with  
impurities, salt and sediments



# Results



## Pure Water

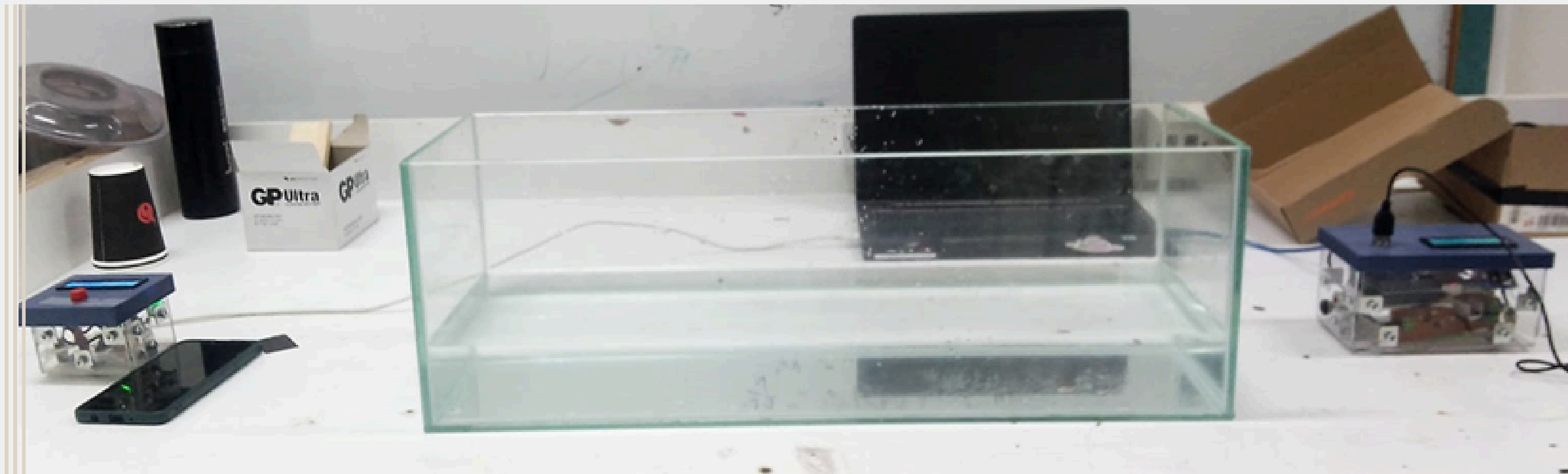

## Pure Water:

distance between transmitter and receiver approximately 1m

The distance the laser can reach is reasonable, but as the distance increases, the scattering increases due to the water absorbing the light energy. The data is complete

## Calculate BER:

Number of bit errors

---

Total number of transmitted bit

Sent data: HI SUB ONE

Data receiver: HI SUB ONE

$$\%BER = (0/10) * 100 = 0$$

# Results



# Salt Water

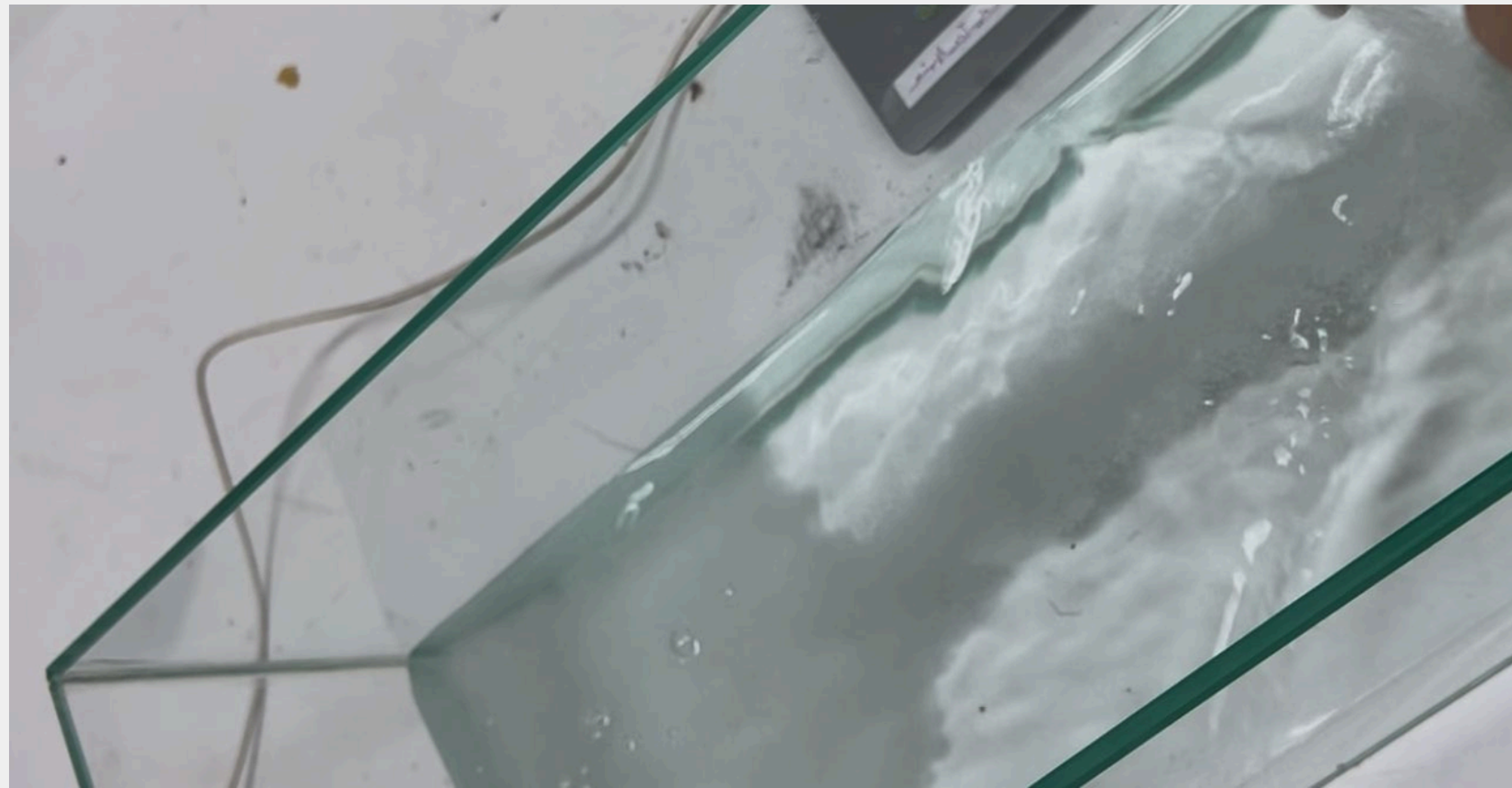

## Salt Water:

distance between transmitter and receiver approximately 1m. Lasers do not travel as effectively over long distances as they do in fresh water.

### Calculate BER:

Number of bit errors

Total number of transmitted bit

Sent data: HI HADEEL LLLOLL

Data receiver: HI HADE LLLODR

$$\text{BER} = (4/16) * 100 = 25 \%$$

# Results



Water contaminated with impurities, salt and sediments

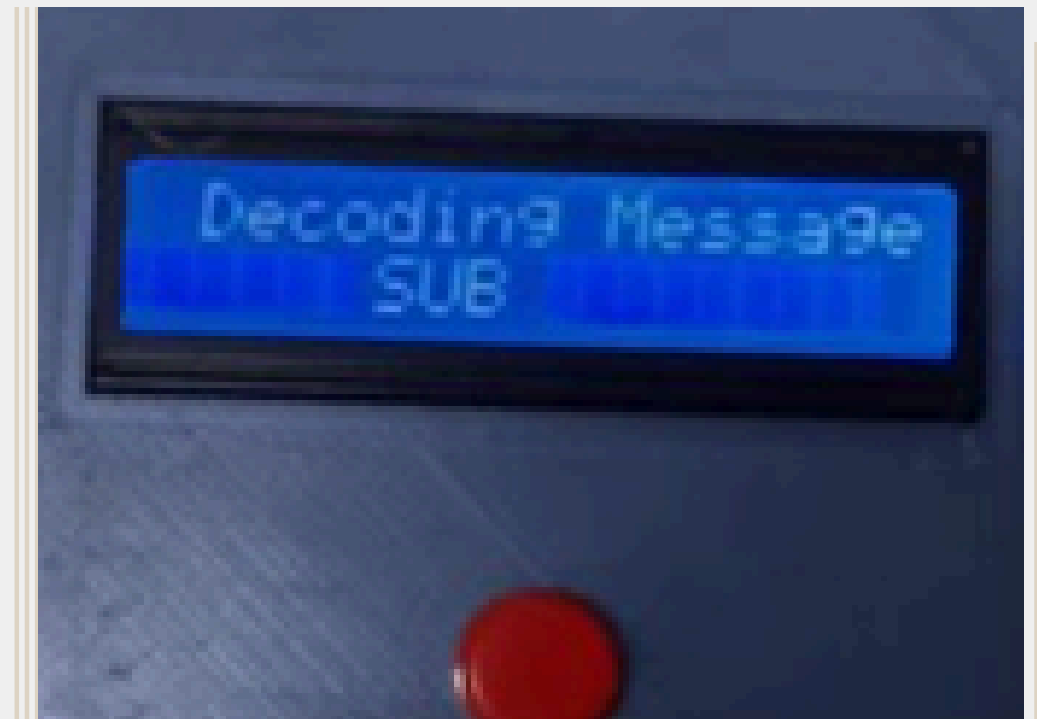
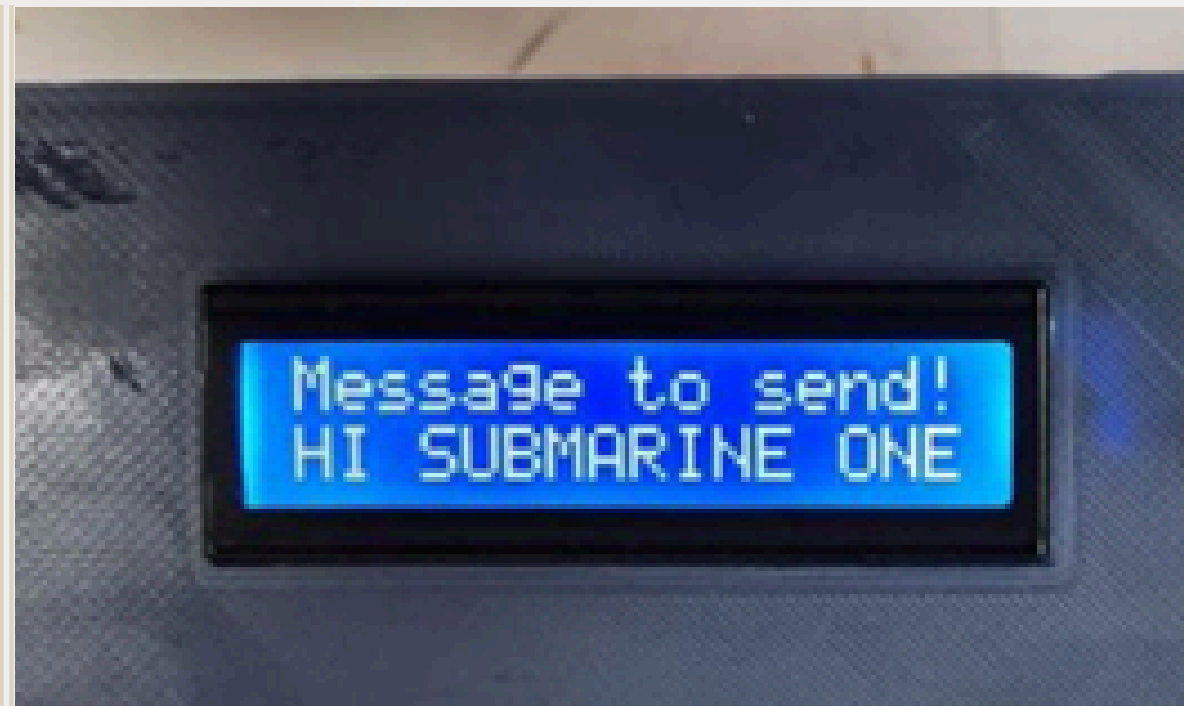
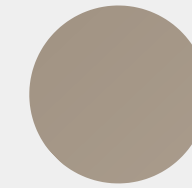

# Results



Water contaminated with impurities, salt and sediments



Water contaminated with impurities, salt and sediments

distance between transmitter and receiver approximately 1m. The distance the data travels may be very small or the signal may not arrive at all if the accumulations are large. High data error rate

### Calculate BER:

Sent data: HI SUBMARINE ONE

Data receiver: SUB

$$\text{BER} = (13/16) * 100 = 81.25\%$$

Sent data: HHHHHHHHHHHHHHHH

Data receiver: HHHHHH

$$\text{BER} = (9/16) * 100 = 56.25\%$$

## In Future

Underwater laser data transmission is a powerful technology but faces challenges like signal attenuation, alignment issues, and environmental interference

Signal  
Attenuation and  
Scattering

Beam  
Alignment and  
Stability

Limited  
Transmission  
Range

Environmental  
Interference

Data Encoding  
and  
Transmission  
Errors

## Conclusions

The underwater laser communication project faced challenges such as high initial costs, limited range due to water clarity, and alignment issues. However, it successfully demonstrated the potential for high-speed, secure communication in specific applications like marine research and underwater vehicles. Laser communication offers advantages like faster data transfer and lower power consumption, but environmental factors remain a limitation.

Thank You So Much

