

AN-NAJAH NATIONAL UNIVERSITY



FACULTY OF ENGINEERING AND INFORMATION TECHNOLOGY

PRESENTED IN PARTIAL FULFILLMENT OF THE REQUIREMENTS FOR BACHELOR
DEGREE IN COMPUTER ENGINEERING

HARDWARE GRADUATION PROJECT

Bus Monitoring System

Authors:

Osama Ismael
Othman Othman

Supervisor:

Dr. Luai Malhis

2-September-2022

List of Figures

1	Arduino Mega 2560	5
2	Arduino Uno	6
3	MCUNode ESP8266	6
4	Raspberry pi 4	7
5	Raspberry pi camera module V2.1	7
6	HC05 Bluetooth Module	8
7	A6 GPRS/GSM module	8
8	RFID reader	9
9	Servo motor	9
10	MG811 CO2 module	10
11	16*2 LCD with IC2	10
12	DC low speed geared motor	11
13	Keypad	11
14	Serial wire	12
15	Micro Serial wire	12
16	Wooden Bus Model	13
17	12V fan	13
18	Landing Page	18
19	Adding New Card or Search to Edit	18
20	Search For Cards	19
21	cards in Firebase Before Adding	19
22	Adding a New Card	19
23	Firestore After adding	20
24	All Cards Page	20

Contents

List of Figures	i
1 Acknowledgments	
2 Disclaimer	
3 Abstract	
4 Introduction	1
5 Constraints Limitations and Earlier Coursework	2
5.1 Constraints Limitations	2
5.1.1 Lack of Resources	2
5.1.2 Time Limit	2
5.1.3 The Power	2
5.1.4 The Cost	2
5.2 Earlier Coursework	2
5.3 Standards and Protocols	3
5.3.1 HTTP	3
5.3.2 IC2	3
5.3.3 SPI	3
6 Literature Review	4
7 Methodology	5
7.1 Equipment and Components	5
7.1.1 Arduino Mega	5
7.1.2 Arduino Uno	5
7.1.3 NodeMCU ESP8266	6
7.1.4 Raspberry Pi 4	7
7.1.5 Raspberry PI Camera V2.1	7
7.1.6 HC-05- Bluetooth Module	7
7.1.7 A6 GPRS/GSM	8
7.1.8 RC522 RFID	8
7.1.9 Servo Motor	9
7.1.10 MG811 CO2 Module	9
7.1.11 L298N Motor Driver Module	10

7.1.12 LCD with IC2 module	10
7.1.13 37mm 24DC Low Speed Geared Motor	11
7.1.14 Keypad	11
7.1.15 Power Sources	12
7.1.16 Serial Cable	12
7.1.17 wires	12
7.1.18 Breadboard	13
7.1.19 Wooden Model	13
7.1.20 12V Fan	13
7.1.21 Buttons	13
7.1.22 LEDs	14
7.1.23 Python	14
7.1.24 React	14
7.1.25 Firebase	14
8 Discussion	15
9 Conclusion	16
A GUI for the web application	18

1 Acknowledgments

“ FIRST AND FOREMOST, WE’D LIKE TO EXPRESS OUR GRATITUDE AND THANKS TO DR.LUAI MALHIS WHO AIDED US IN COMPLETING OUR GRADUATION PROJECT. HE DIDN’T HESITATE FOR A MOMENT TO SUPPORT US TO COMPLETE OUR PROJECT. FURTHERMORE, WE’D ALSO TO EXPRESS OUR APPRECIATION TO OUR FAMILIES AND FRIENDS FOR THEIR GREAT SUPPORT. NOT FORGETTING EVERYONE WHO ASSISTED AND EMBOLDENED US FOR WORKING ON OUR PROJECT. WE WOULDN’T BE ABLE TO FINISH THIS PROJECT WITHOUT YOU.”

THIS REPORT WAS WRITTEN BY STUDENTS AT THE COMPUTER ENGINEERING DEPARTMENT, FACULTY OF ENGINEERING, AN-NAJAH NATIONAL UNIVERSITY. IT HAS NOT BEEN ALTERED OR CORRECTED, OTHER THAN EDITORIAL CORRECTIONS, AS A RESULT OF ASSESSMENT AND IT MAY CONTAIN LANGUAGE AS WELL AS CONTENT ERRORS. THE VIEWS EXPRESSED IN IT TOGETHER WITH ANY OUTCOMES AND RECOMMENDATIONS ARE SOLELY THOSE OF THE STUDENTS. AN-NAJAH NATIONAL UNIVERSITY ACCEPTS NO RESPONSIBILITY OR LIABILITY FOR THE CONSEQUENCES OF THIS REPORT BEING USED FOR A PURPOSE OTHER THAN THE PURPOSE FOR WHICH IT WAS COMMISSIONED.

3 Abstract

The world is developing rapidly in many areas nowadays. Especially in the technology field. One of those areas where technology is developed and used is "Transportation and Buses Systems". Safety, Payment, Monitoring, and Management Systems are examples of the field of Buses and transportation field is developing. Across the world, many bus companies use technology to keep track, organize their buses, and manage them. On the other hand, that is not the case locally. Al Taneeb, Al Waleed, and Al Tamimi are some of the local companies that run the majority of the buses across the country, they use their systems, unfortunately, those systems are old and not that practical. So, to keep pace with this development, local bus companies should use more technology. Facilitating the management of buses for the companies, ensuring safety for passengers, and making their life a little bit easier.

Bus Monitoring System is a system for a company to track its buses' routes and monitor their movement. Easing the supervision of the whole system by providing subsystems to monitor the buses by using a GPS to locate the bus and track it alongside the path. as well as a camera streaming all the time to keep records on the server in case of any problem. Safety is important as well! A CO2 detector saves passengers' lives by refreshing the air if there is a lack of oxygen. As well as an "emergency button" to call the police and provide the location in case of any attacks or robbery. regarding the communication between buses and stations, there will be independent communication to keep the system working in case the server goes down showing a bus is arriving at a station or willing to leave one. Finally, in the payment system, RFID cards will be used to pay for bus rides.

Note that there is no internal controller in the demo meaning that an external controller will be implemented to simulate the steering wheel by using an application on the phone, and some buttons to communicate with the station.

Other systems can be found but they are not covering all implemented features. Most of the already existing systems rely on servers and cannot work without them. More security and safety measures are added. No system is perfect but constant development and adapting to cover weak spots is the way to improve the system.

4 Introduction

Although the use of traditional buses is common locally, it still wastes a lot of time for passengers, for example, passengers waste their time standing to buy tickets to ride buses, and they may waste another time riding on the bus while paying cash, in addition to the fact that the driver will waste time when receiving their money and returning change, which may cause more late passengers who pay to be on time for their appointments.

The Oxygen levels may decrease in the bus without any notice from the driver nor passengers, causing harm to them, especially since the windows of modern buses are closed and cannot be opened.

For buses' companies, buses are not tracked and monitored. This may cause a problem contacting the buses reaching them in case of emergency or even providing some luxury apps for the clients to locate the buses and approximate the time to move toward them. As well as providing camera recordings to check if there is any danger or violations.

Bus monitoring system aims to provide safety and security in the bus for passengers. In addition to facilitate charge the cards. This system has multiple features that achieve safety and security like:

1. There is a CO2 detector in the bus, so when the CO2 is higher than the safe percentage. A fan added in the top of the bus will be turned on automatically refreshing the air making the CO2 level dropping down again.
2. The ability to see everything inside the bus by using a camera that will be streaming all the time.
3. Every RFID card has a unique ID, so every customer can charge his/her card on the station or any other certified sale point.
4. Turnstile gates working on RFID cards to ensure payments(will be simulated as bus door in the demo).
5. Emergency button to call the police and provide the location for them.
6. GPS tracking the bus path all the time.
7. interactive stations that are connected to buses and notify passengers if there is a bus coming and if it is about to leave.

The research will be demonstrating the problem and how it could be solved. Then providing a methodology and some devices and equipment that used to partially solve the problem. and then suggesting some extra steps that can be taken to improve the solution and make it closer to what a perfect system should be.

5 Constraints Limitations and Earlier Coursework

5.1 Constraints Limitations

5.1.1 Lack of Resources

It's not easy to find all the components needed in the local electronics stores. How to deal with these components is another story. Some problems with their functionality or misusing them may be caused by the lack of experience.

5.1.2 Time Limit

To finish the project with the desired details and features, it takes big time because the project will pass through many stages, including the learning interval, planning and designing interval, building and debugging interval. In addition, there will be enhancements to improve project's performance. and finally, the testing interval. Furthermore, the semester is limited for three months.

5.1.3 The Power

Dealing with the power is a big deal because there are multiple modules in the project. Each component varies than the others. In the bus, there will be some 12 Volts, 6 Volts batteries and power-bank to get the needed power to run it. Other modules are less challenging and can be powered by a USB with low current needed.

5.1.4 The Cost

The project has multiple components, each will cost money, But the point of such project is to find an economic system with lower cost as possible to meet the financial level. as well as make it attractive to anyone who is willing to use it.

5.2 Earlier Coursework

The knowledge of the participants in Hardware was gained in the Computer Engineering Department from all the courses that we have taken such as: Microprocessor, Micro-controller, Electrical Circuits, Digital Design, Critical Thinking Research and Computer Networks. Other knowledge was gained by participating in some courses and sessions online and with the local IEEE branch. for example:

1. Arduino course
2. ESP8266 & ESP32 course
3. Raspberry Pi 4 courses and articles
4. React library courses and training
5. Firebase

5.3 Standards and Protocols

5.3.1 HTTP

Hypertext Transfer Protocol (HTTP) is an application-layer protocol for transmitting hypermedia documents, such as HTML. The HTTP protocol was designed to communicate between web browsers and web servers, but it can also be used for other purposes. HTTP is a stateless protocol, this means that the server does not keep any data (state) between two requests.[5]

5.3.2 I2C

The I2C communication bus is very popular and broadly used by many electronic devices. It can be easily implemented in electronic devices which require communication between a master and multiple slaves or even multiple master devices. The easy implementation is because it requires only 2 pins for communication (SDA and SCK) between up to almost 128 (112) devices when using 7 bits addressing and up to almost 1024 (1008) devices when using 10 bits addressing.[4]

5.3.3 SPI

Serial Peripheral Interface (SPI) is an interface bus commonly used to send data between microcontrollers and small peripherals, sensors and SD cards are common. It uses separate clock (sck) and data lines (MISO, MOSI), along with a select line (cs) to choose the device willing to contact to.[7]

6 Literature Review

Cities growth is one of the challenging trends among the world. Providing services in a certain quality might be hard these days but for sure it is getting harder by time. Water, electricity, buildings, healthcare, and transportation systems are some of the aspects and surly there is more.

One of the challenges among large cities is the transportation system. There are multiple models of transportation including Air travelling, Sea travelling and Land transportation. Those 3 models are applicable in most countries across the world. Air travelling is applicable across travelling across countries. Some counties actually use airlines to connect cities or states inside the same country. Sea travelling or Maritime traveling is one of the most efficient way to move a large number of passengers and payloads. It is cheap, cost effective and amazing way to see the world. Last way of travelling is land travelling. Trains, buses, cars and trucks are some of the vehicles used to travel by land[8].

Returning back to Block cements called cities, cars Buses and Subways metro are the most systems used to travel by land. Subways requires a huge budget to be applied and ofcourse the most important a suitable and supportive infrastructure. Subways require a large wide streets and a very organized infrastructure and a strong built buildings to endure the constructions work around them.

Cars and buses are more suitable for remote places and poor countries but they face a lot of problems due to traffic, narrow streets and old systems they are using. Security and safety systems are another story, payment systems are varying between company to other.

Palestine is one of the countries that are considered a poor one. It is occupied and has no sovereignty over it's land. This and more making a subway system looks like a dream for those people. What about cars and buses? well, cars and buses are the most used in this country. Though, it is still challenging to manage these buses into more efficient way due to traffic, and the bad infrastructure in most cities as well as the traditional system of a bus is moving from point A to point B among cities but not inside the same city. There are some exceptions ofcourse but still it is not the case in most places.

To run a bus system (or any other transportation system) it should be a convenient easy to use and ease the life of the passengers. Safety and emergency precautions are needed too. Making the system more time efficient and less time consuming would make it better. Monitoring and safety are important too. Monitoring can help running some Machine Learning models to improve the system efficiency and to pass the peak times with less effort. It also helps improving the whole system by noticing where are the problems and who to be improved which means providing a better service and a more reliable one. Tracking is a good point too! but how? well, if the buses were tracked all the time this will provide data on how where and why the paths can be changed into depending on the behavior of the passengers. This feature can be also used to provide an application that shows the buses in real time and estimate how much time it would take a bus to reach a certain point. Stations are another way to improve the service. Having a screen showing the buses are at this station and indicating if one is leaving is useful. Missing a bus is very common among people just because they were late for seconds or distracted by an event. But indications saves their trips by telling that the bus is leaving, Harry up!

7 Methodology

7.1 Equipment and Components

7.1.1 Arduino Mega

Arduino Mega is a microcontroller that has 54 digital input/output pins, as well as 16 analog pins. It is designed for projects that require more inputs/outputs pins [2].

The Arduino Mega2560 has been used in the bus to control the motors and their drivers using a mobile application interacting by an HC-05 Bluetooth module, contacting with the station module to provide the needed interaction, reading an CO2 sensor then controlling a fan in the top of the bus providing more healthy, reading a RFID, controlling bunch of buttons, a GSM and GPS controlled by serial as well as a raspberry pi4. It also to control a servo motor to open and close the door when the card passes into the RFID module.

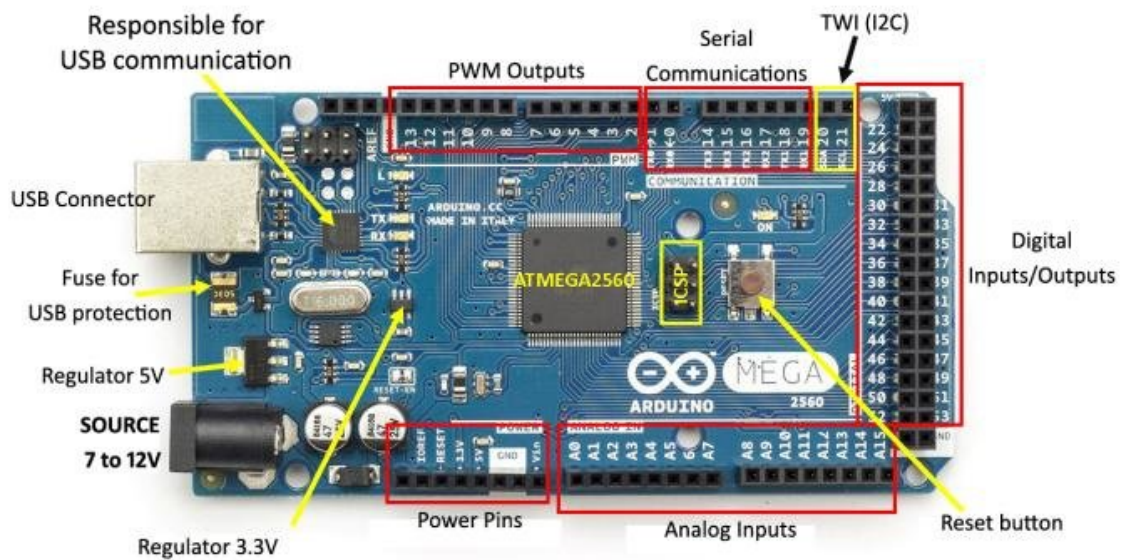

Figure 1: Arduino Mega 2560

7.1.2 Arduino Uno

It is a microcontroller board developed by Arduino.c. It has 6 analog inputs, 14 digital outputs/inputs pins. A 16 MHz ceramic resonator (CSTCE16M0V53-R0) [3].

The Arduino Uno has been used used in the station module to control the LCD announcing a bus has arrived or about to leave. Other way it has been used is to read the keypad to charge the customer's cards and send this value serially to the ESP8266.

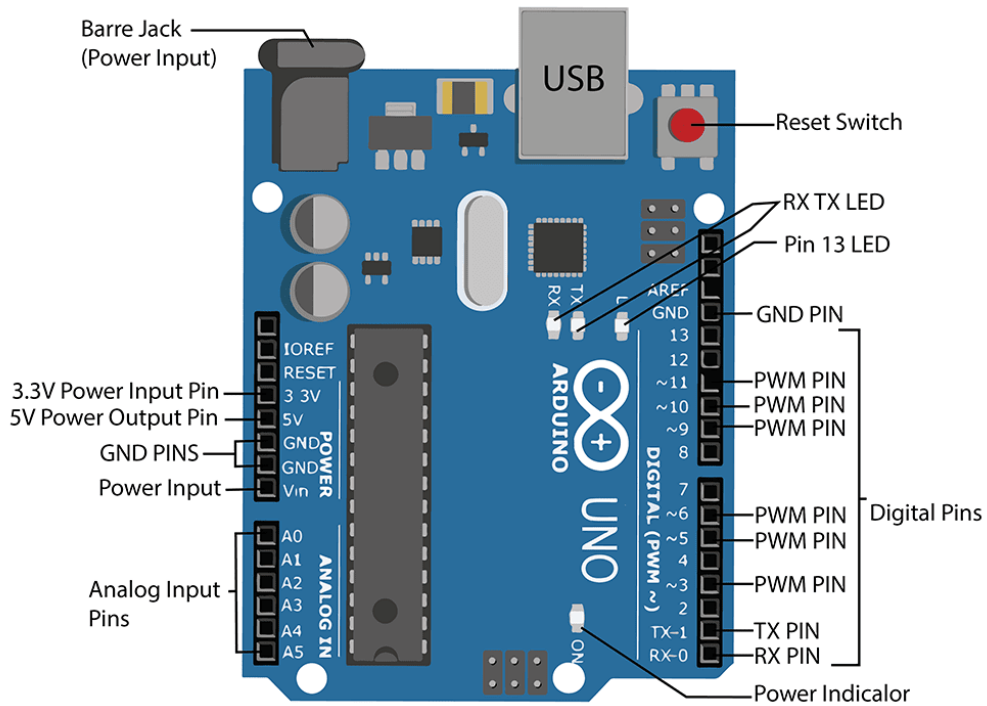

Figure 2: Arduino Uno

7.1.3 NodeMCU ESP8266

NodeMCU ESP8266 is an open source platform based on ESP8266 that can connect objects using Wi-Fi to send and receive the data [1].

the NodeMCU ESP8266 has been used in order to connect the RFID to scan the cards and read its ID and to get the price from keypad serially with Arduino Uno. In addition, It has been used to get and post the value of the card to/from the Firebase.

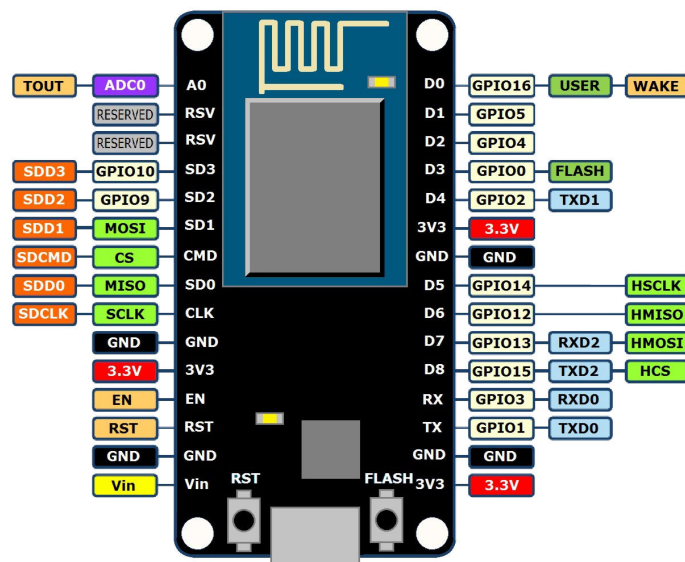

Figure 3: MCUNode ESP8266

7.1.4 Raspberry Pi 4

A mighty capable micro controller that can do whatever a computer can. It has a special OS (a Linux distribution) which means it can browse the internet, being programmed , run applications and many other things. The raspberry pi used to stream camera all the time and to interact with the Firebase.

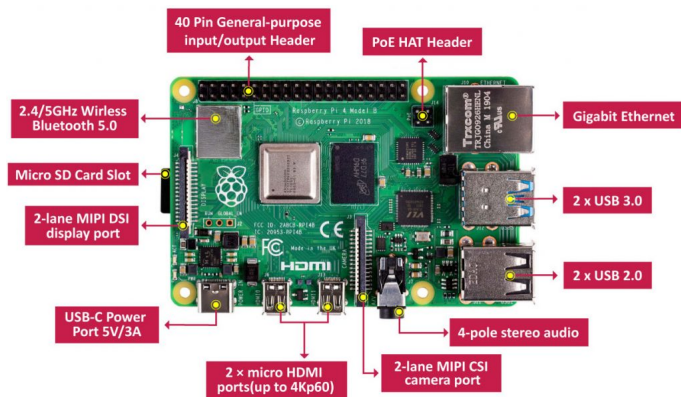

Figure 4: Raspberry pi 4

7.1.5 Raspberry PI Camera V2.1

Used to capture the video to be streamed.

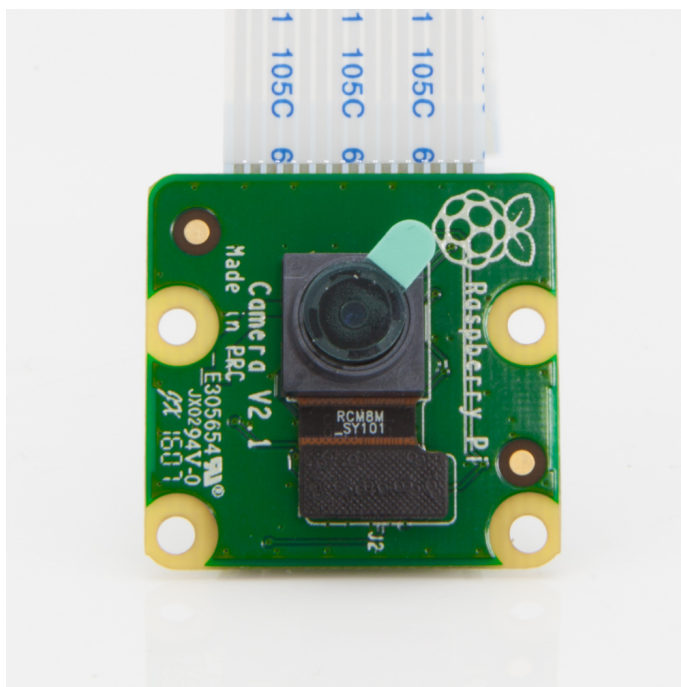

Figure 5: Raspberry pi camera module V2.1

7.1.6 HC-05- Bluetooth Module

A popular simple communication module that has 2 modes (command mode and user mode). The command mode is the mode that can be used to set the proprieties to the module such as name, password and binding ...etc. Other mode is the data mode which is used 99% of the time transferring data to other modules on a wireless communication with a frequency of 2.4GHz. It

has A VCC pin (3.7 - 6 Volts), GND pin, TX and RX pins for transferring data. The HC05 module has been used to communicate between station and bus module. In addition is has also has been used to control the bus module motors using a mobile application.

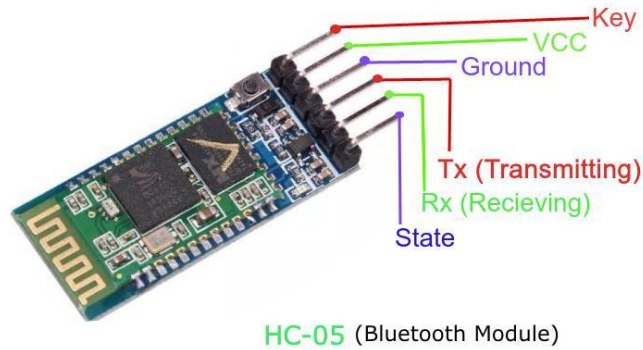

Figure 6: HC05 Bluetooth Module

7.1.7 A6 GPRS/GSM

The A6 module provides a serial port to communicate via GPRS. Arduino (or any other controller) can interact with the module using a (TX,RX) serial. The module is suitable with applications that do not require Wi-Fi and mainly SMS messages or calls.

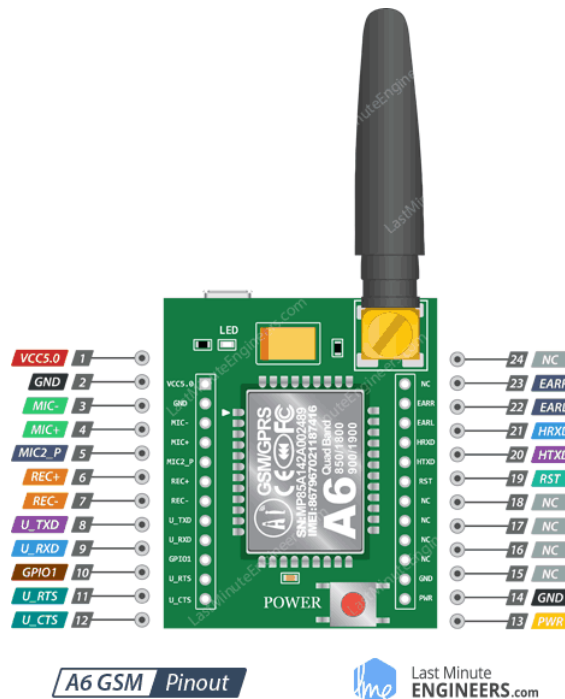

Figure 7: A6 GPRS/GSM module

7.1.8 RC522 RFID

An RFID or radio frequency identification system is a system that consists of two main components, a card or tag attached to the object to be identified, and a reader that reads the card (or the tag).

the reader consists of a radio frequency module and an antenna that generates a high frequency

electromagnetic field(13.56 MHz). The Card (or the tag) is a passive device -it does not have a battery-. It consists of a microchip that stores and processes information, and an antenna for receiving and transmitting a signal.

The module has 8 pins VCC and GND for powering (note that vcc is 3.3Volts and applying 5V will damage the module). IRQ, Reset and SPI communication (SS, MISO, MOSI and SCK).

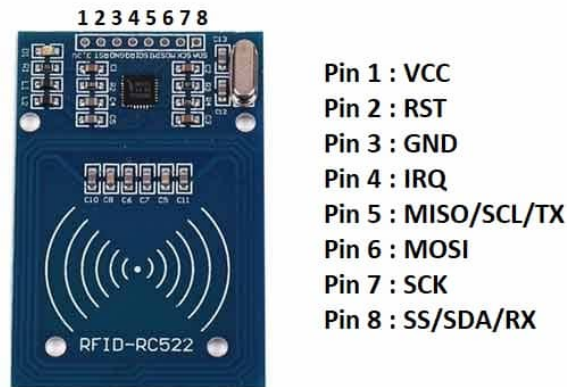

Figure 8: RFID reader

7.1.9 Servo Motor

A servo motor used to implement a door that opens or do not open depending on the value of the card.



Figure 9: Servo motor

7.1.10 MG811 CO2 Module

MG811 is a sensor that is sensitive to CO2 and less sensitive to other gases providing lower current if the CO2 level is high and Higher current when the CO2 level drops down. The interaction can be done by reading the sensor as digital but the easier way is to read analog signal directly using VCC GND for power and Aout for analog.



Figure 10: MG811 CO2 module

7.1.11 L298N Motor Driver Module

This module provides an H-Bridge to control the directions of the DC motors. It takes 5 - 35 volts as an input voltage and reflects it as output. Other inputs used to control the direction and speed using pulse width modulation.

7.1.12 LCD with IC2 module

16*2 LCD has been used with IC2 to indicate the messages in the bus, station and card charging module.



Figure 11: 16*2 LCD with IC2

7.1.13 37mm 24DC Low Speed Geared Motor

4 Dc motors used to mock the bus movement and being controlled by a mobile application.



Figure 12: DC low speed geared motor

7.1.14 Keypad

A 4*4 keypad matrix used to get numbers and values to charge the RFID cards.



Figure 13: Keypad

7.1.15 Power Sources

Many power sources used in this project including batteries power banks and a USB cables that are connected to a computer or a suitable power adapter

7.1.16 Serial Cable

Serial cables used to program the Arduino and the ESP and to connect between the Arduino and the Raspberry pi.



Figure 14: Serial wire



Figure 15: Micro Serial wire

7.1.17 wires

Wires used to connect the components.

7.1.18 Breadboard

Breadboard used to ease wiring some parts and to supply power for multiple parts using 1 wire from the source.

7.1.19 Wooden Model

Bus wooden model to mock a real bus shape.



Figure 16: Wooden Bus Model

7.1.20 12V Fan

A 12V fan used to refresh the air if the CO2 level is going higher than a certain safe level.



Figure 17: 12V fan

7.1.21 Buttons

Buttons used to indicate a SOS call and a bus leaving station.

7.1.22 LEDs

Used to indicate the card if it was accepted, rejected or no status for any card.

7.1.23 Python

A high-level programming language that is structured to support Object Oriented Programming and Functional Programming. I has been used to interact with Firebase on the raspberry pi.

7.1.24 React

React is a JavaScript library for building user interface. It is used to build single page applications, also to create reusable UI components[9]. It is a good choice to create a web page to ti interact with the APIs on the server and show the cards that the customers have.

7.1.25 Firebase

Firebase is a platform developed by Google for creating mobile and web applications[6]. Developers can use Firebase as a server to get, post,delete data.

8 Discussion

The main purpose of the project is to improve the user experience of the local bus system in Palestine and other poor countries that cannot afford to build a subway or train rails. This is definitely what have been done. Including some safety features, improving user experience, having a better independent payment system and separate some functionalities from the server and improving the communication and make the system more reliable.

[**ArduinoTesting**]

CO2 sensor and air flow system are great but still can have a negative side not detecting if the CO2 rising is because of fire or it is normal due to crowded bus. Other limitation is that the bus door is working on the RFID but that must be replaced with a tripod turnstile and using a special card for emergencies (someone have forgot his bag and want to get it and leave this will not be possible with the current system but this can be solved easily by having some emergency cards. Bluetooth is not a good system to connect the bus with the station and must be replaced with an ESP or any other wifi module to provide more reliable connection. Firebase can have more than just an ID with a value, this way can have more functionality such as gifts or classes for clients and maybe more data about the trips so this can be collected to provide offers to increase sales. Cards can have some functionality or encoding so it can be used even if there is no internet or the server is down so there will be no need for the server for a certain amount of trips.

9 Conclusion

There is no perfect system and as the technology improves the more the systems improved. It is just a big circle aims to provide the best way with the available technologies.

Improvement is a journey that never ends. and here is some points this system can be passing through to be mature enough.

1. ML... ML ... ML, Machine learning is the best way to study the data that collected from the users and this makes it possible to notice how to improve the service.
2. Independency, the system is dependent on the server in way too many cases but providing some ways to save the state and sync it when possible will provide more reliable system and still can work with down servers and last for maybe some days providing enough time to save the user data.
3. security and safety is a big problem that can never be done from. Safety of the passengers and how to protect them in case of accidents and fire is a way from being done and this could be a very good topic to dive into.
4. Some problems were mentioned in the discussion so another look would be great to get a bigger idea.

References

- [1] Arduino.cc. *Getting Started w/ NodeMCU ESP8266 on Arduino IDE*. URL: <https://create.arduino.cc/projecthub/electropeak/getting-started-w-nodemcu-esp8266-on-arduino-ide-28184f>. (accessed: 28.8.2022).
- [2] Arduino.cc. *Getting Started with Arduino MEGA2560*. URL: <https://www.arduino.cc/en/Guide/ArduinoMega2560>. (accessed: 28.8.2022).
- [3] Arduino.cc. *Uno R3*. URL: <https://docs.arduino.cc/hardware/uno-rev3>. (accessed 28.8.2022).
- [4] Dejan. *How I2C Communication Works? Arduino and I2C Tutorial*. URL: <https://howtomechatronics.com/tutorials/arduino/how-i2c-communication-works-and-how-to-use-it-with-arduino/>. (accessed: 1.9.2022).
- [5] MDN web docs. *HTTP*. URL: <https://developer.mozilla.org/en-US/docs/Web/HTTP>. (accessed: 1.9.2022).
- [6] fredericl. *Google Acquires Firebase To Help Developers Build Better Real-Time Apps*. URL: <https://techcrunch.com/2014/10/21/google-acquires-firebase-to-help-developers-build-better-realtime-apps/>. (accessed: 1.9.2022).
- [7] MIKE GRUSIN. *Serial Peripheral Interface (SPI)*. URL: <https://learn.sparkfun.com/tutorials/serial-peripheral-interface-spi/all>. (accessed: 1.9.2022).
- [8] Dr. Jean-Paul Rodrigue. *Transportation Modes, Modal Competition and Modal Shift*. URL: <https://transportgeography.org/contents/chapter5/transportation-modes-modal-competition-modal-shift/>. (accessed: 1.9.2022).
- [9] W3Schools. *React*. URL: https://www.w3schools.com/react/?fbclid=IwAR3jqLaNgY2jTc4eJQ7E-285Sq_zJ7Ecf6tpm5EH1u3R7IAwbgw8nvgqyWU. (accessed: 1.9.2022).

A GUI for the web application

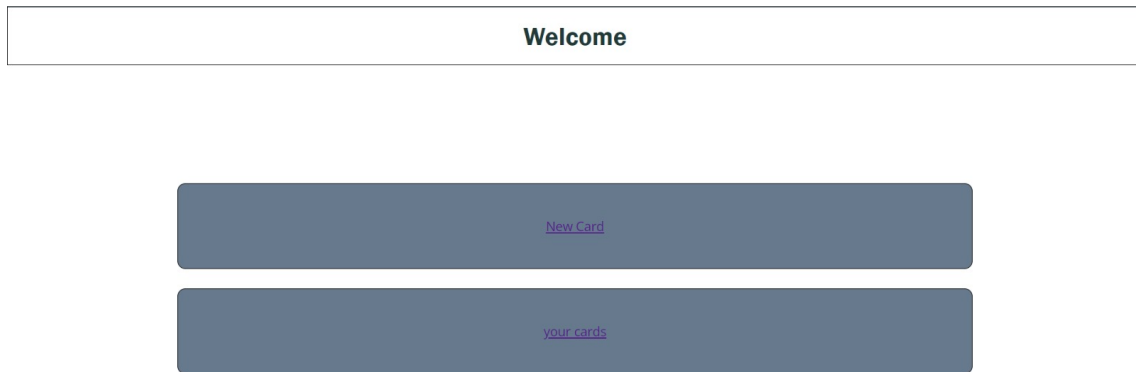

Figure 18: Landing Page

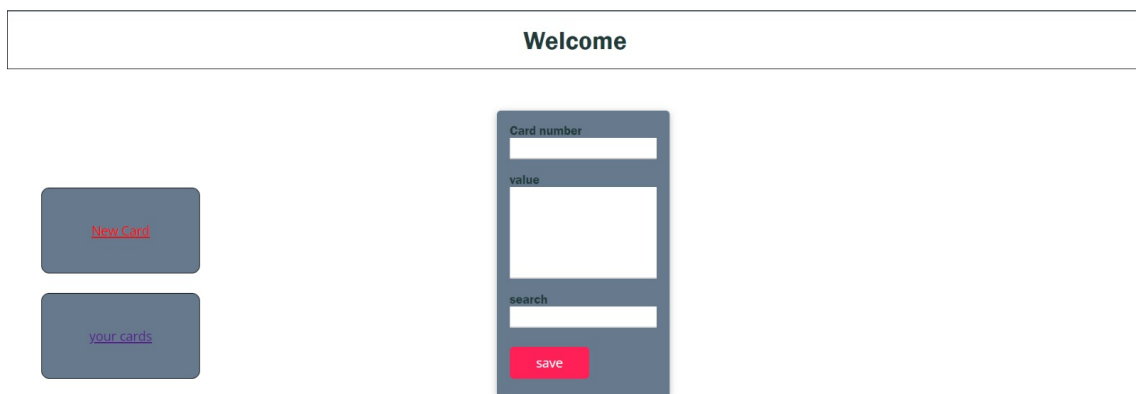

Figure 19: Adding New Card or Search to Edit

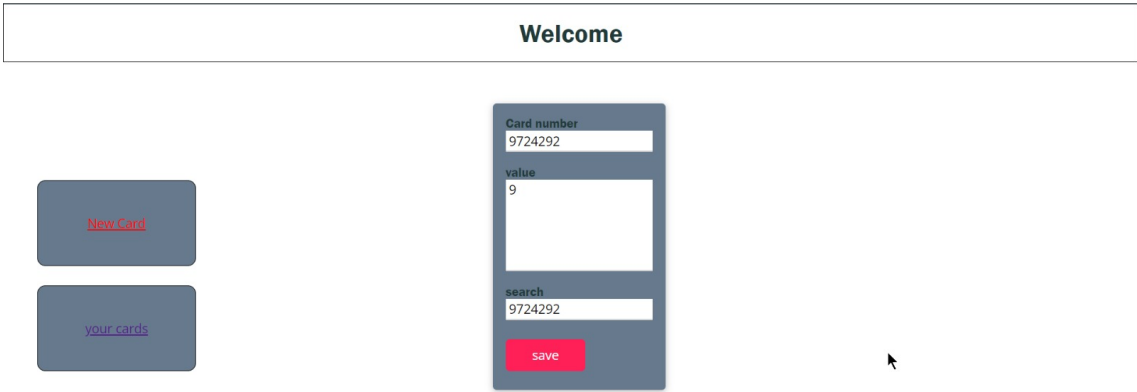

Figure 20: Search For Cards

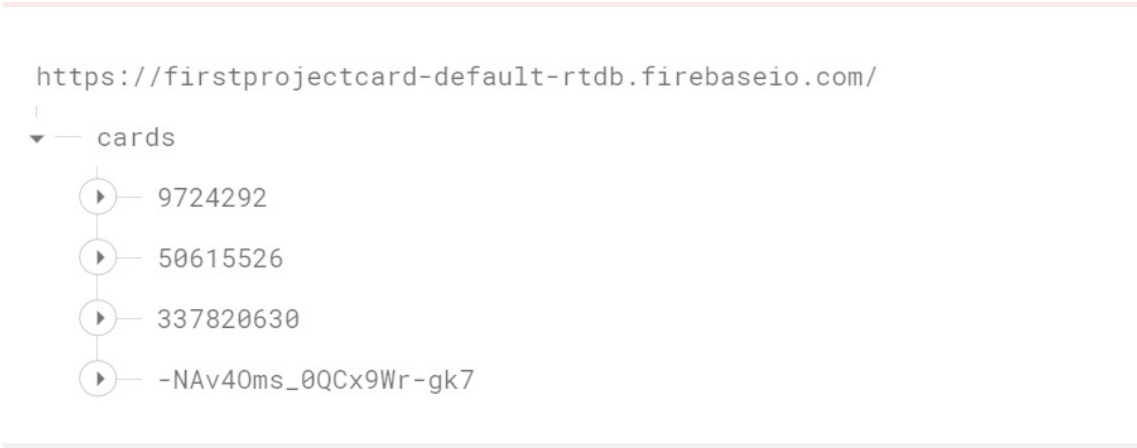

Figure 21: cards in Firebase Before Adding

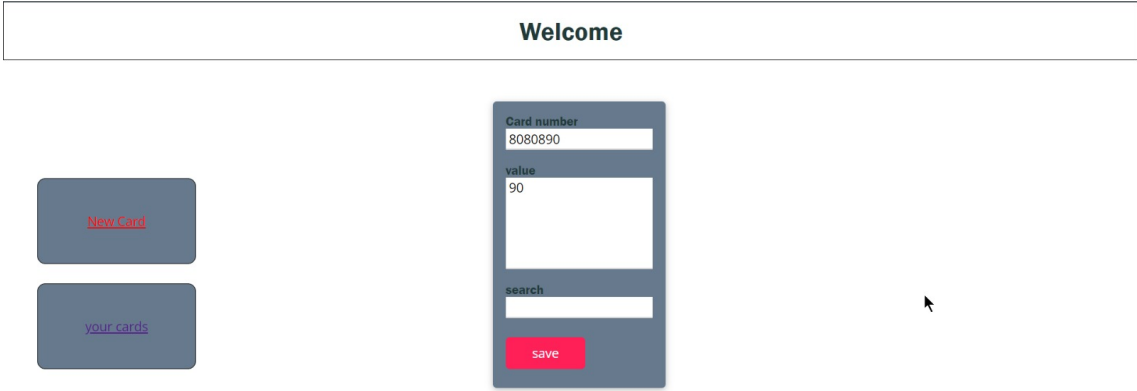

Figure 22: Adding a New Card

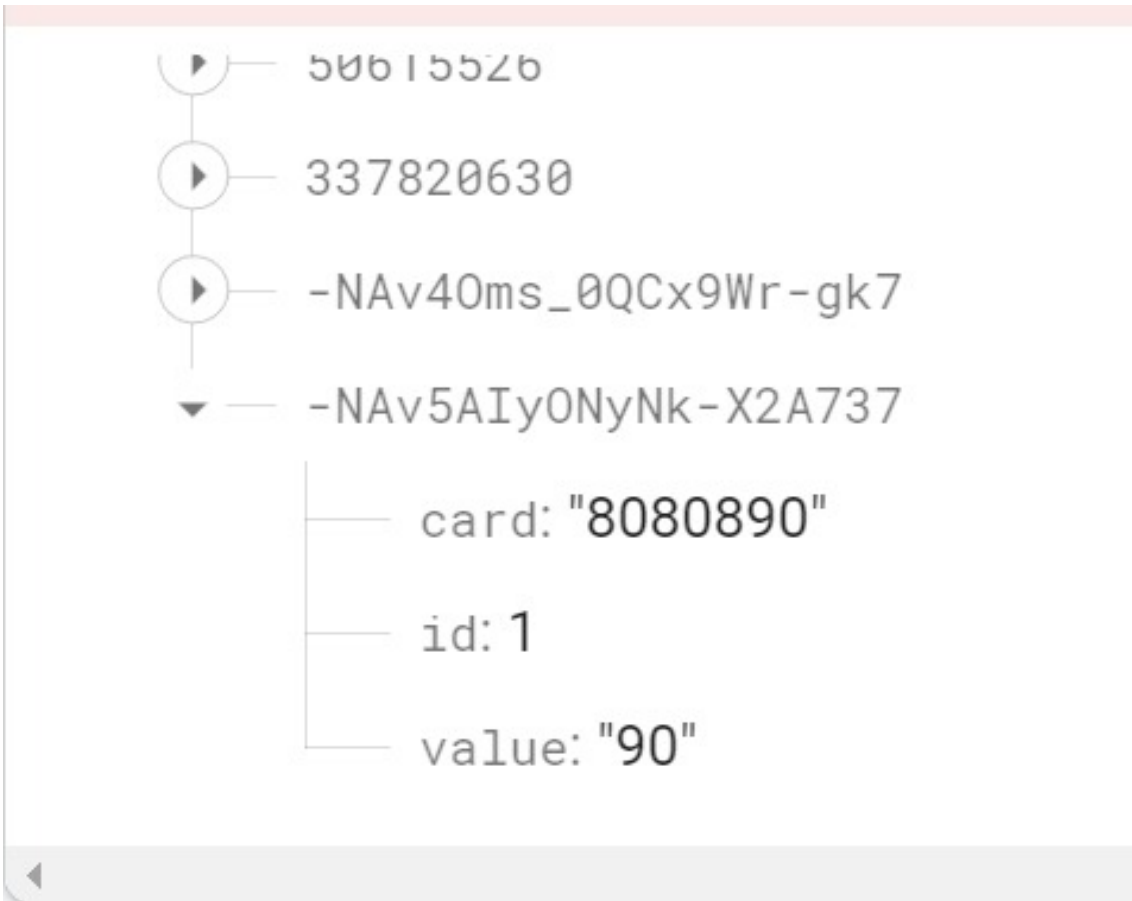

Figure 23: Firebase After adding

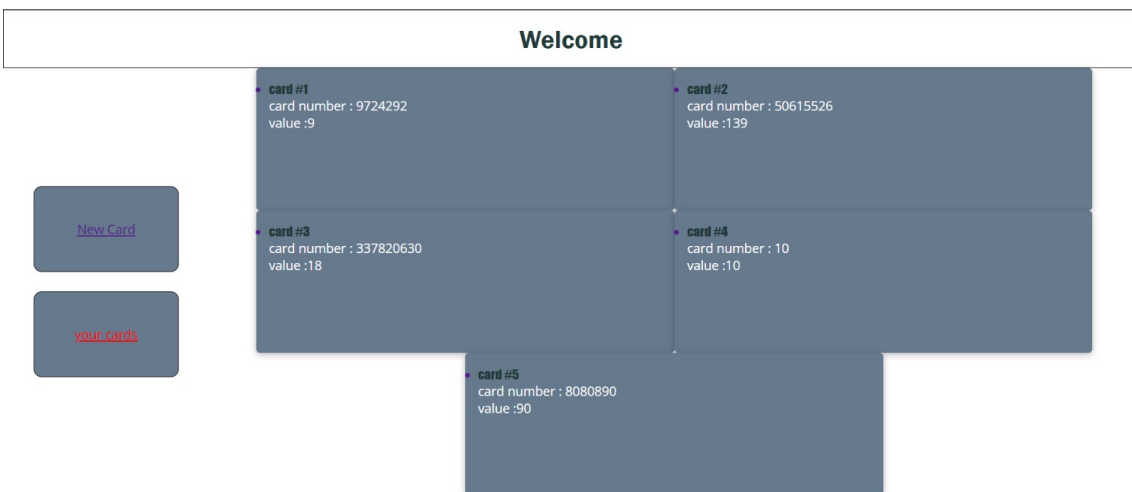

Figure 24: All Cards Page