



An-Najah National University

**Faculty of Engineering & Information Technology
Electrical Engineering Department**

Graduation Project Report 2

Off-grid solar system design.

prepared by:

Zaid khayat (11939052)

Farah ghazal (11821433)

Adnan Basha (11717928)

Supervisor:

Dr. Raed Jaber

Academic Year: 2023/2024

Table of Contents :

Chapter1: Abstract and Introduction .

Chapter 2 : Definition of the off grid system and system component .

Chapter 3 : solar cells :

a- Definition solar cells

b- Types of solar cells and their comparison

c- Characteristics of solar cells

Chapter 4 : Characteristics of inverter and charge control :

Defining the DC to AC converter, its types, and ways to connect it to the rest of the system

Chapter 5:batteries :

a- Types of batteries, definition, characteristics, advantages, disadvantages and comparison

b- Factors that help determine the appropriate type of solar battery

C-Comparison of the lithium batteries used in our project with the best gel type lead acid batteries common in our country

Chapter 6:Project's Mechanism of work for one house

part 1: Project location and appropriate design angles for solar panels

part 2 : Calculation of the electrical energy consumed

part 3 : Calculation of the required solar cell system capacity

part 4: Calculate the number and capacity of batteries suitable for the system

part 5 : Design the inverters charging control suitable for the system's capacity

Part 6: Implementation of the project by MATLAB software

part 7: Mounting Structure design for each solar system

part 8: Earthing System design for each solar system

part 9: Electricity Cabinet design for each solar system

part 10: Main distribution box design for each solar system and home distribution box

part 11: Calculate the required cable capacity for each system

part 12: Economic feasibility of the project

part 13: Implementation of the project by pv syst

Chapter 7: Project's Mechanism of work for 12 houses together in one network

part 1 : Designing a complete system for all 12 houses, and calculating the devices needed for the system

part 2: Economic feasibility of a system designed to supply the electricity needs of 12 homes

part 3: A comparison between installing a system for each home and installing a complete system for all homes

Chapter 8: System component specifications

Chapter 9 : Conclusion , References .

Chapter1: Abstract and Introduction

Abstract :

The residents of the Altual area, the village of atuof , the city Tubas , face many problems, the most important of which is the failure to secure their necessary electricity needs ; Because the occupation and settlers do not allow the electricity company to connect its extensions to that area and provide the necessary energy for its residents, as they depend for their livelihood on diesel generators that convert to electrical energy, but diesel costs are expensive, and they are unable to secure the diesel they need to provide their need for electricity, so We searched for the best project that would provide them with their needs and reduce costs over time, off grid solar project was the best .

The off grid solar cell system is the best project to provide the electricity needs of the region's residents, as the region is suitable for installing a solar cell system. Solar panels produce electricity throughout the day, and store the excess energy in batteries to feed the loads at night .

In this system, we used highly efficient solar cells, and designed the cells at appropriate angles with solar radiation to give the best energy yield. We also used high-efficiency, long-life, temperature-balanced batteries .

Introduction :

There are many Palestinian villages in various regions whose residents live in conditions that lack proper living, especially the basic things that must be present in any home regardless of the nature established for it and the environment in which it embraces.. The most prominent of which is electricity.. These villages do not receive electricity at all for several reasons, including their distance from the first electricity supplier or the high prices that exceed their ability and prevent them from communicating directly with the company. Or perhaps one of the most important reasons is the geographical location of these villages, which plays an important role in the presence of the Israeli occupation And the imposition of restrictions on the lands has the greatest impact on the lack of electricity in those areas... Villagers are tempted to use the first alternative, which is diesel generators, to obtain solar energy, due to the pollution it causes to the environment as a result of the rising gases.

Looking at Palestine, we find that electricity consumption is relatively high, and therefore the price is high

Electricity per kilowatt-hour because electrical energy in Palestine is purchased at exorbitant amounts, Where electrical energy constitutes 31% of the total energy consumed according to the energy balance prepared by the Central Bureau of Statistics. The household sector in Palestine is the largest consumer of this energy with 60%, followed by the services sector and the commercial sector 26%, and the industrial sector consumes 13%; While the agricultural sector consumes less than 1%.

Due to the local political and economic conditions, Palestine still lacks local sources of electricity production to meet market needs, with the exception of the Gaza Power Plant and renewable energy projects; Palestine depends mainly on import sources for this energy from countries

Neighboring countries, including Israel, Egypt and Jordan. As a result, the price of electricity for each Palestinian house according to the following study (“the citizen pays a “household subscription” 0.44 agora for each kilowatt, if the monthly consumption ranges from one kilowatt to 160 kilowatt-hours).

It is necessary to think of an alternative way to reduce electricity consumption from the supplying companies and thus reduce the monthly payment for each citizen. If we look at the geographical location of Palestine, we see that it is among the countries located in the so-called solar belt (the area bounded between latitudes 40 degrees north and 40 degrees south) with more than 300 sunny days per year with an average daily brightness of about 8 hours, increasing in summer and decreasing in winter , as the average solar radiation per day reaches approximately 5.4 solar kilowatts per square meter, which is equivalent to an annual production of 1950 kilowatt-hours of energy, which enabled Palestine to be one of the best areas to exploit solar energy, and the possibility of investing in it is economically feasible.

We found that Palestine possesses high solar energy that must be exploited through the use of the PV system to produce electricity, not only in remote villages that lack electricity, but also needed by citizens with high monthly electricity consumption, which leads to the disconnection of the current from them sometimes by the company. This is the best alternative way to solve this is the problem .

In our project, we shed light and searched for some remote villages that do not have access to electricity, and we found the Al-Twal area in the village of Atouf in the Tubas governorate, which we will study on how to use the PV system to generate electricity for them.

Chapter 2 : Definition of the off grid system and system component :

All solar power systems work on the same basic principles. Solar panels first convert solar energy or sunlight into DC power using what is known as the photovoltaic (PV) effect. The DC power can then be stored in a battery or converted by a solar inverter into AC power which can be used to run home appliances. Depending on the type of system, excess solar energy can either be fed into the electricity grid for credits, or stored in a variety of different battery storage systems.

We ask ourselves this question (What Are The Main Components Of A Solar System)?

1. Solar Panels:



Solar panels are the most visible element of your system, which is why you're likely the most familiar with it. They are, in essence, the "face" of solar. If you go out and look up and down your street right now, you will likely be able to tell who does and doesn't have solar energy powering their home purely by looking for solar panels on their roofs.

The way that solar panels work is that the panels generate DC electricity as sunlight, or solar irradiation, stimulates electrons to move through solar cells that are in-built into the solar panels. Contrary to what some may think, it is the sunlight itself, and not heat, that generates

the electricity. In fact, overheated panels can become less efficient, similar to a computer overheating. Thus, any solar panel you choose must be able to withstand the warm Australian climate for around 25 years .

➤ Types Of Solar Panels:

- Polycrystalline silicon panels use multiple silicon crystals used together. They're a budget-conscious option but less efficient than monocrystalline panels.

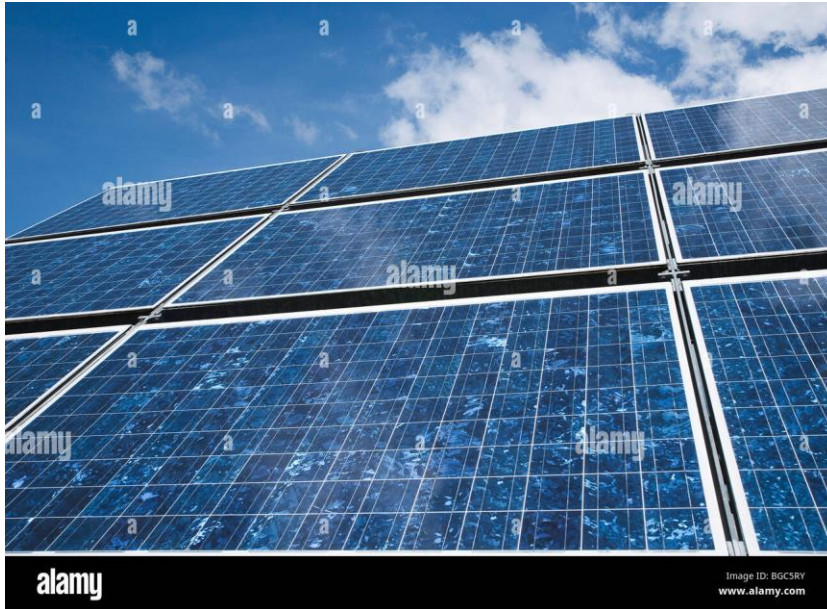

- Monocrystalline silicon panels use a single crystal. They are the industry standard and the most efficient solar panels. However, they are the most expensive option.



- Thin-film solar cells are less common than monocrystalline and polycrystalline. These solar cells are made using amorphous silicon and are the most flexible type of solar panel. These flexible solar panels may be a good option if you need to install panels on a curved surface. You may see these used for RV solar panels, but generally, these panels

are the least efficient.

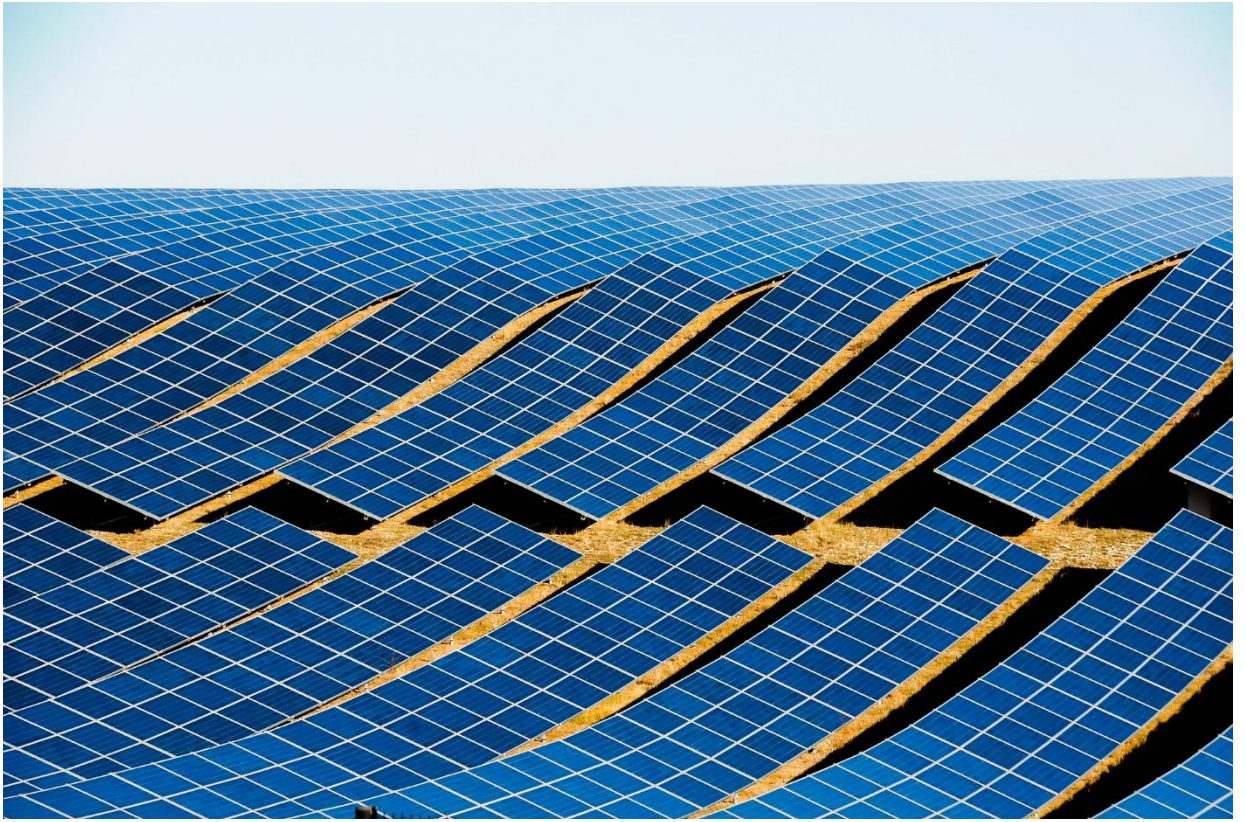

2. Inverters:



**String Inverter
(1 per solar system)**

or



**Micro-inverter
(1 per solar panel)**

Inverters are a crucial part of any solar energy system. Their purpose is to convert the DC electricity that the solar panels produce into 240V AC electricity, which is what powers everything in your home. The inverter is a hardworking piece of equipment that works constantly throughout the lifetime of your system – so it tends to be the piece most likely to have faults. This means they usually only have a warranty of around 10 years. For this reason, we will always recommend that you choose a high quality inverter that is easily serviceable such as Fronius, ABB, Sungrow or SolarEdge.

Inverter Technology – String Inverters vs Microinverters

The two main types of inverters are string inverters and microinverters. A string inverter is installed onto a wall in a shaded area and will convert the energy from a string of panels (for residential systems this is usually the entire system) into AC electricity to be used in your home or business. Microinverters are installed on the back of each panel, allowing the energy from the panels to exist independently from each other. When partial shading occurs on one panel in

a string inverter system, the performance of the rest of the panels are also affected (as demonstrated below). Microinverters are the solution to this, as they allow the panels to operate independently but also come with an increase in price. There are also power optimizers, which are the middle-of-the-road approach between the two, as they are cheaper than microinverters but somewhat less effective. Shading isn't always a critical issue so microinverters aren't always necessary.



PARTIAL PANEL SHADING WITH AND WITHOUT MICRO-INVERTERS

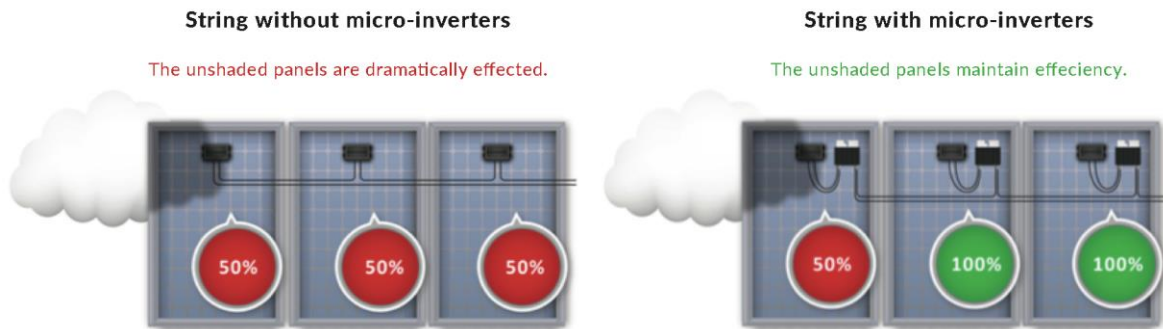

3. Racks And Mounts:



Racks and mounts aren't electrical components, but they're essential to your solar system nonetheless. The racks and mounting attach your solar panels to your roof or mount them in the ground. The racking quality is critical, and the correct installation is even more vital. If panels are mounted at the wrong angle, the efficiency of your system will suffer.

❖ Types Of Solar Mounts:

Roof Mounts: This is the most common type of mounting used to attach a solar array to a structure, such as a home, tiny house, or commercial building. Roof mounts can also be used to install rigid solar panels on boats and vehicles, such as RVs and vans.



2. Ground Mounts: Basic ground mounts attach a solar array on top of concrete piers closer to the ground for stability. Panels are mounted at a fixed angle but can be adjusted manually as seasons change. You can use this option if roof space is insufficient. However, both ground and pole-mounted panels require a lot of land space. Therefore, this installation is not typically used residentially and is more common in commercial or agricultural settings.



3: Pole Mounts: This type of mounting is less common and connects a solar array on a pole, secured into the ground by concrete. Pole mounts raise panels higher than standard ground mounts and sometimes use tracking systems that tilt the solar panels automatically to capture optimal sunshine throughout the day and year.



4. Solar Power Meter

Another optional component is a solar power meter, also known as power system metering. A solar power meter allows you to monitor how much solar power your panels supply to your home. A power meter helps you understand and monitor the performance of your system. If needed, you can troubleshoot, adjust, or repair your system to achieve maximum efficiency.



5. Solar Batteries

Solar batteries are an optional component in a solar power system. Solar batteries, like other batteries, store energy for later use. A solar battery is used as storage for the power generated during the day, so it can be used throughout the night when there is no sunlight to generate power. If you want or need to store a large amount of energy, you can use more than one battery, known as a battery bank.



6. Charge Controllers

A charge controller is a device that manages the flow of electricity from your solar panels to a battery. A solar charge controller is another optional component, and if you don't have a battery in your system, you won't need a charge controller.

Charge controllers work to ensure the batteries in your system are charged to an optional level to preserve the longevity of the battery bank. Solar charge controllers come in two main types: MPPT Maximum Power Point Tracking (MPPT) and Pulse Width Modulation (PWM).



Final design of the components of the solar system:

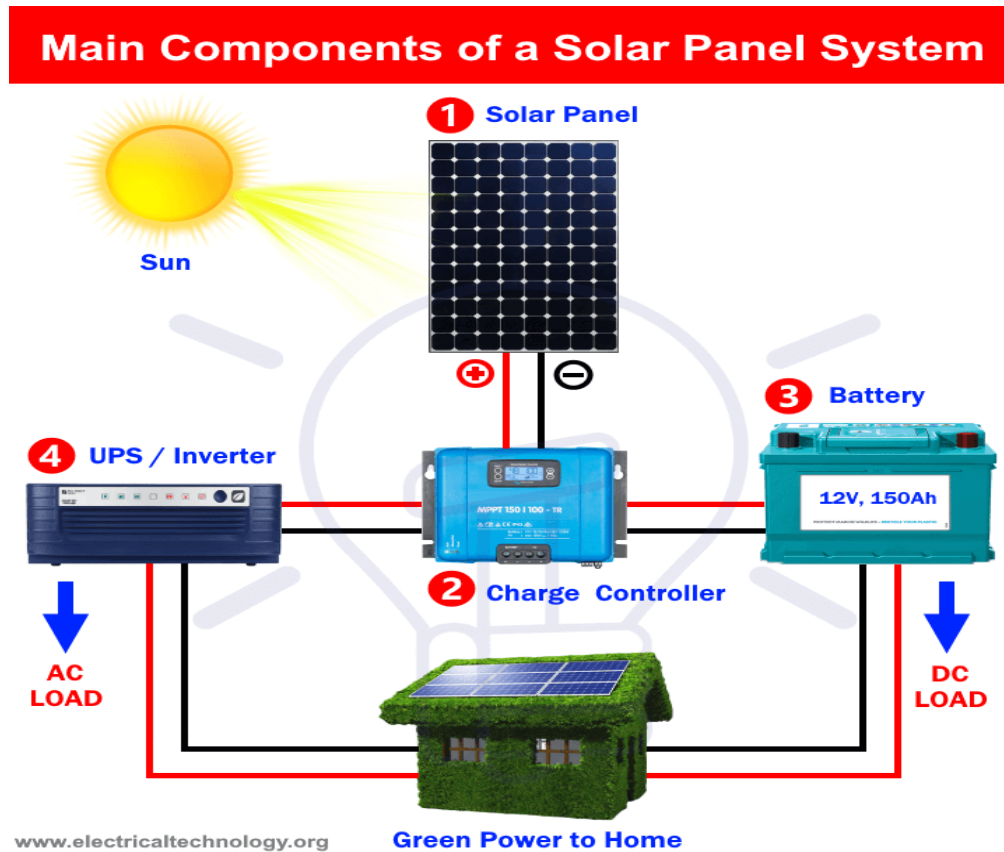

The three main types of solar power systems

1. **On-grid** - also known as a grid-tie or grid-feed solar system
2. **Off-grid** - also known as a stand-alone power system (SAPS)
3. **Hybrid** - grid-connected solar system with battery storage

1- On-grid system:

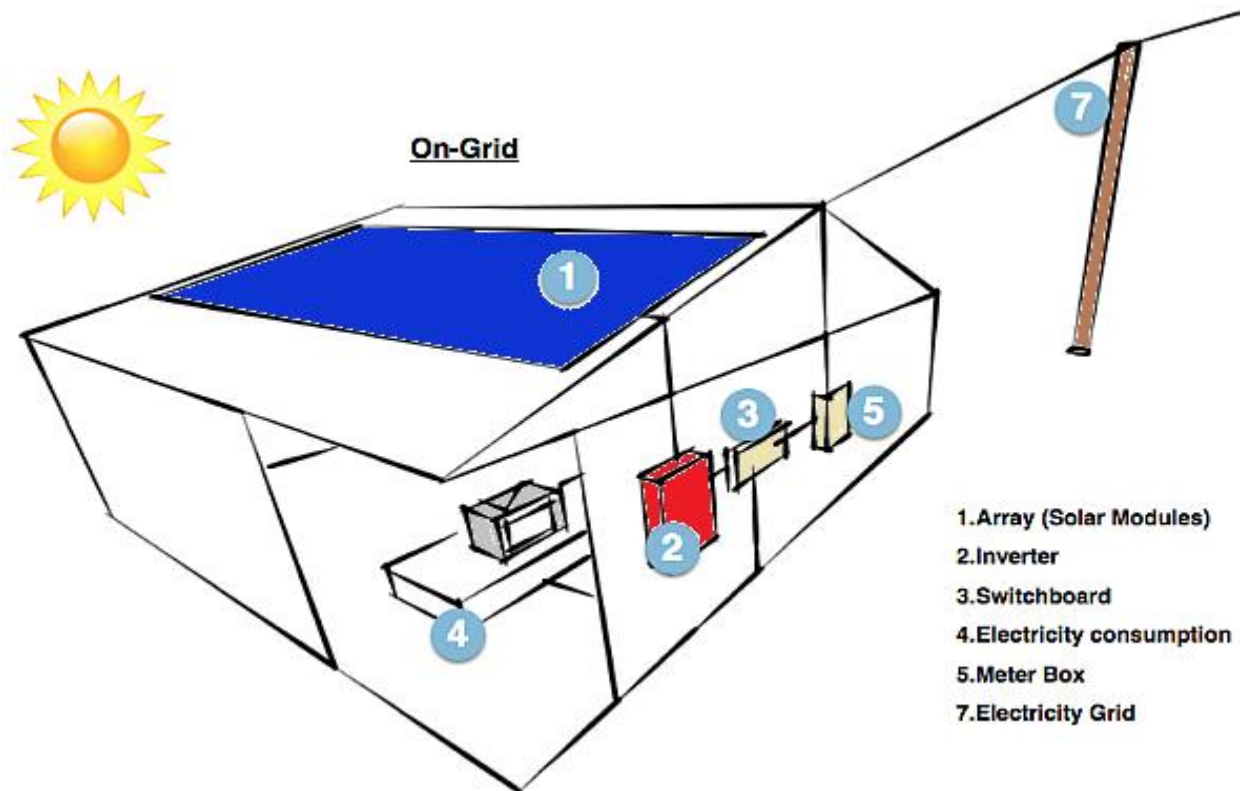

On-grid or grid-tie solar systems are by far the most common and widely used by homes and businesses. These systems do not need batteries and use either solar inverters or micro-inverters and are connected to the public electricity grid. Any excess solar power that you generate is exported to the electricity grid and you usually get paid a feed-in-tariff (FiT) or credits for the energy you export.

Unlike hybrid systems, on-grid solar systems are not able to function or generate electricity during a blackout due to safety reasons. Since blackouts usually occur when the electricity grid is damaged; If the solar inverter was still feeding electricity into a damaged grid it would risk the safety of the people repairing the fault/s in the network. Most hybrid solar systems with battery storage are able to automatically isolate from the grid (known as islanding) and continue to supply some power during a blackout.

Batteries are able to be added to on-grid systems at a later stage if required. The Tesla Powerwall 2 is a popular AC battery system which can be added to an existing solar system.

In an on-grid system, this is what happens after electricity reaches the switchboard:

- **The meter.** Excess solar energy runs through the meter, which calculates how much power you are either exporting or importing (purchasing).
- **Metering systems** work differently in many states and countries around the world. In this description I am assuming that the meter is only measuring the electricity being exported to the grid, as is the case in most of Australia. In some states, meters measure all solar electricity produced by your system, and therefore your electricity will run through your meter *before* reaching the switchboard and not after it. In some areas (currently in California), the meter measures both production and export, and the consumer is charged (or credited) for net electricity used over a month or year period. I will explain more about metering in a later blog.
- **The electricity grid.** Electricity that is sent to the grid from your solar system can then be used by other consumers on the grid (your neighbours). When your solar system is not operating, or you are using more electricity than your system is producing, you will start importing or consuming electricity from the grid.

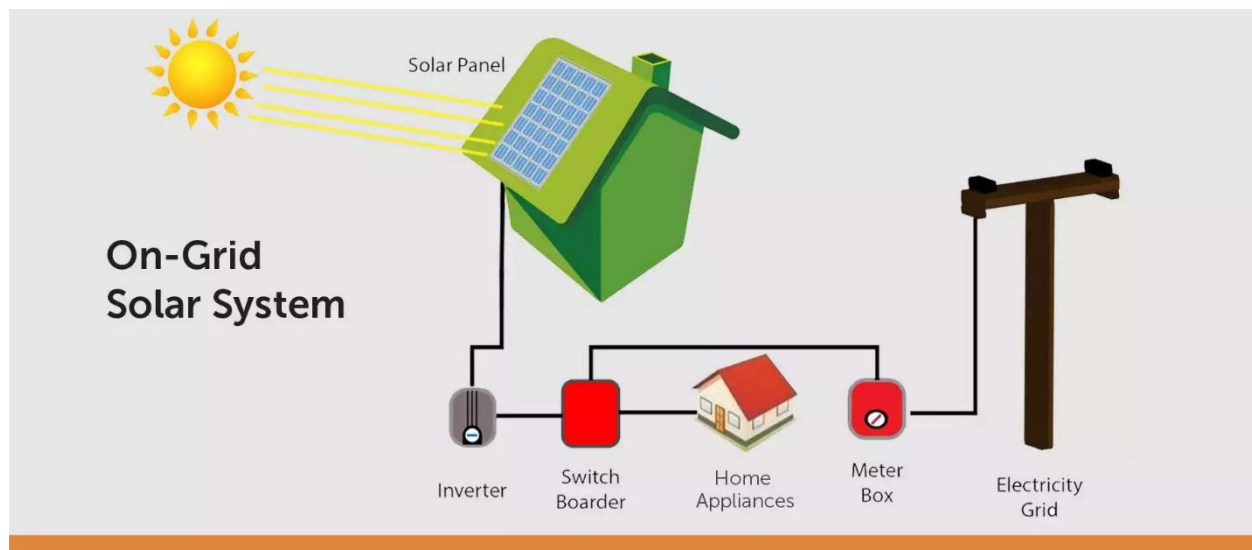

2- Off-Grid System

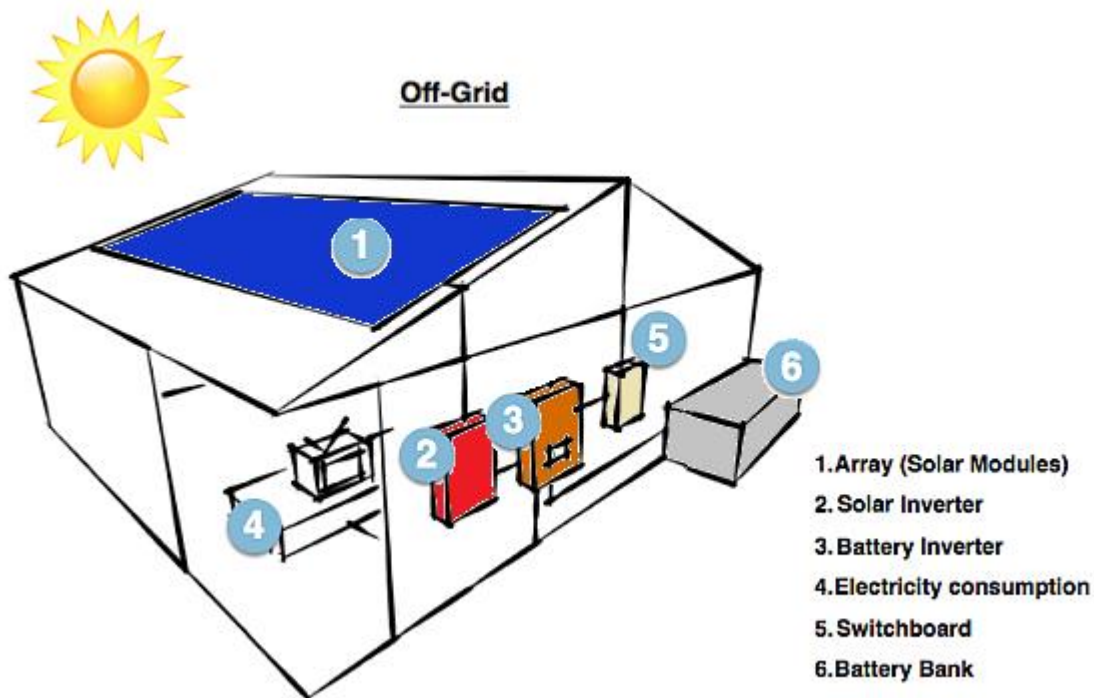

An off-grid system is not connected to the electricity grid and therefore requires battery storage. Off-grid solar systems must be designed appropriately so that they will generate enough power throughout the year and have enough battery capacity to meet the home's requirements, even in the depths of winter when there is generally much less sunlight.

The high cost of batteries and off-grid inverters means off-grid systems are much more expensive than on-grid systems and so are usually only needed in more remote areas that are far from the electricity grid. However battery costs are reducing rapidly, so there is now a growing market for off-grid solar battery systems even in cities and towns.

There are different types of off-grid systems which we will go into more detail later, but for now I will keep it simple. The above diagram is for a larger AC coupled system. In smaller scale DC coupled systems, a solar charge controller is used to manage the battery charging, then the DC power is converted to AC using an off-grid inverter and sent to your home appliances.

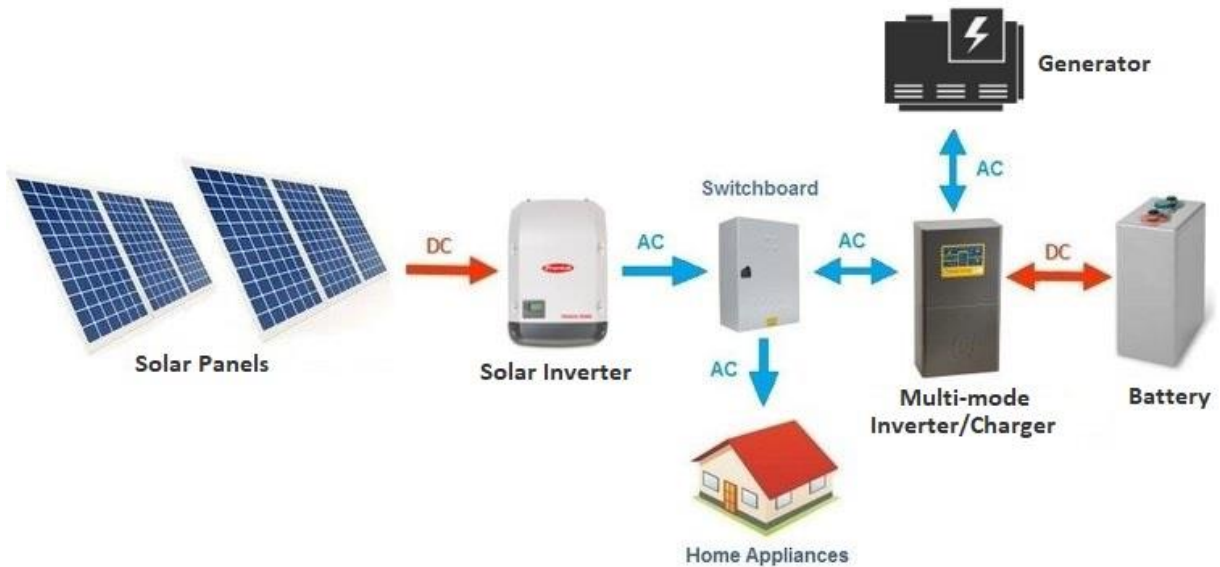

- **The battery bank.** In an off-grid system there is no public electricity grid. Once solar power is used by the appliances in your property, any excess power will be sent to your battery bank. Once the battery is full it will stop receiving power from the solar system. When your solar system is not working (night time or cloudy days), your appliances will draw power from the batteries.
- **Backup Generator.** For times of the year when the batteries are low on charge and the weather is very cloudy you will generally need a backup power source, such as a backup generator or gen-set. The size of the gen-set (measured in kVA) should to be adequate to supply your house and charge the batteries at the same time.

3- Hybrid System

Modern hybrid systems combine solar and battery storage in one and are now available in many different forms and configurations. Due to the decreasing cost of battery storage, systems that are already connected to the electricity grid can start taking advantage of battery storage as well. This means being able to store solar energy that is generated during the day and using it at night. When the stored energy is depleted, the grid is there as a back up, allowing consumers to have the best of both worlds. Hybrid systems are also able to charge the batteries using cheap off-peak electricity (usually after midnight to 6am).

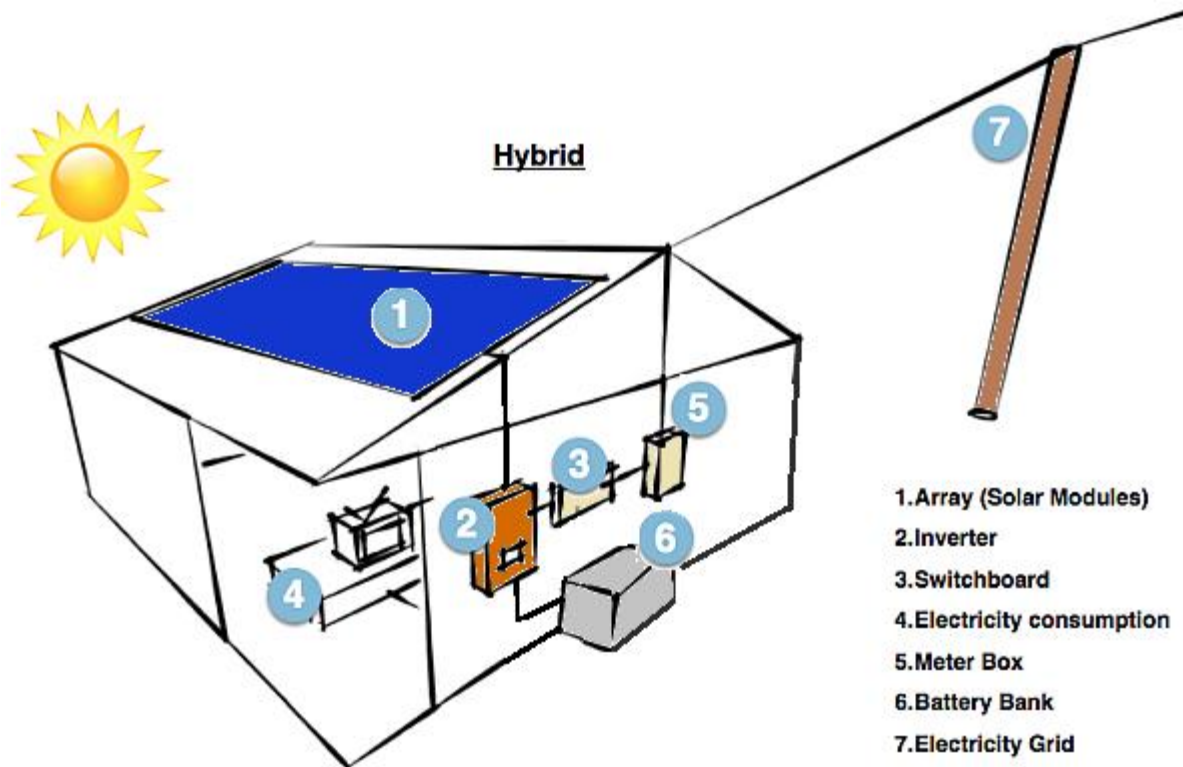

There are also different ways to design hybrid systems but we will keep it simple for now. To learn more about the different hybrid and off-grid power systems refer to **our detailed** guide to home solar battery systems.

- **The battery bank.** In a hybrid system once the solar power is used by the appliances in your property, any excess power will be sent to the battery bank. Once the battery bank is fully charged, it will stop receiving power from the solar system. The energy from the battery can then be discharged and used to power your home, usually during the peak evening period when the cost of electricity is typically at it's highest.
- **The meter and electricity grid.** Depending on how your hybrid system is set up and whether your utility allows it, once your batteries are fully charged excess solar power not required by your appliances can be exported to the grid via your meter. When your solar system is not in use, and if you have drained the usable power in your batteries your appliances will then start drawing power from the grid.



OFF-GRID-SYSTEM:

❖ *In this project we will use a solar power system (OFF-GRID)*

We'll talk about how off-grid solar energy works?

And what is The most important benefits of the off-grid solar system?

➤ *First, we will talk about the principle of work:*

The ingenuity of an off-grid solar energy system is made-up of the efficiency of its components. A solar energy system's solar panels, charge controllers, battery bank, and inverters all work together to provide your laptop or refrigerator energy, and this is how.

Off-grid solar energy systems work by...

Solar Panels (PV array). Solar panels are set either on your rooftop or in an open yard or property space. The Sunlight is soaked up by the solar panels and transferred to the charge controllers.

Charge Controllers. The charge controller is the "delivery man" between the solar panels, the inverters, and the battery bank. Charge controllers also act as a regulator, ensuring that the amount of power received through the solar panels does not overload the battery, instead keep the battery fully charged and top it off when needed. The charge controllers either deliver the energy directly as DC power to your lights or to the inverters to be converted into AC power for household appliances and all excess energy goes to the...

Battery Bank. With the charge controllers feeding energy to the batteries, the battery bank acts as the heart of the off-grid solar system, as it stores up excess energy for cloudy days and nights, when needed it pumps electricity to the...

Inverters. Lastly, inverters convert the DC (direct current) power into AC power which is passed on to be digested by your electronics or appliances as DC power and allows you to running any thing.

➤ *The most important benefits of the off-grid solar system:*

1. Independence!



By investing in an off-grid solar system, you no longer rely on your county or state for your electrical needs. You are fully in control. Whatever becomes of the economy, your energy needs are met. By. YOU.

2. Protects & Preserves the Environment



Can you get cleaner energy than the SUN? Fossil fuels, coal, nuclear energy... We think not. By partnering with an off-grid solar system you can help reduce pollution and carbon footprint, which allows for purer air and a healthier environment.

3. Lightning. Thunder. Blackouts!

Even after a fierce thunderstorm, owning an off-grid solar system keeps your home running while your neighbors may experience a blackout or power outage. You can thank the heart of your off-grid solar system for this, Mr. Battery Bank.

4. Saves You Money (in the long run)

While the initial costs for a off-grid solar system may be high, it pays itself off. At the “end of the day” you will have zero electric bills.

5. These are ideal for remote areas where there is no power access from the grid.

*Grid failures and shutdowns will not affect your power supply.
and It saves huge amount of electricity bills*

➤ *Disadvantage:*

1) These devices cannot be used in places where there is less sunshine or cloudy weather.

2) *It requires high installation charge*

3) *It requires high maintenance cost.*

4) *Off-grid systems require you to purchase a backup battery which can be bulky and expensive.*

- *Some of the applications about the off-grid system:
Off-grid photovoltaic systems have numerous applications:*

Bringing electrical power to rural and remote areas

Emergency power supply during natural disasters

Mobile solar systems are used for sea and land expeditions as well as camping, and hiking

Used as power backup for areas facing frequent power cuts

To run solar water pump systems for the supply of water for feedstock, irrigation, and drinking

Businesses can rely on on-grid solar systems to meet their daily requirements, as well as earn income from the excess power generated. On bright sunny days, buildings can generate enough solar energy to power appliances, lights, water heating systems, etc.

- *this picture show the difference between 3 solar system:*

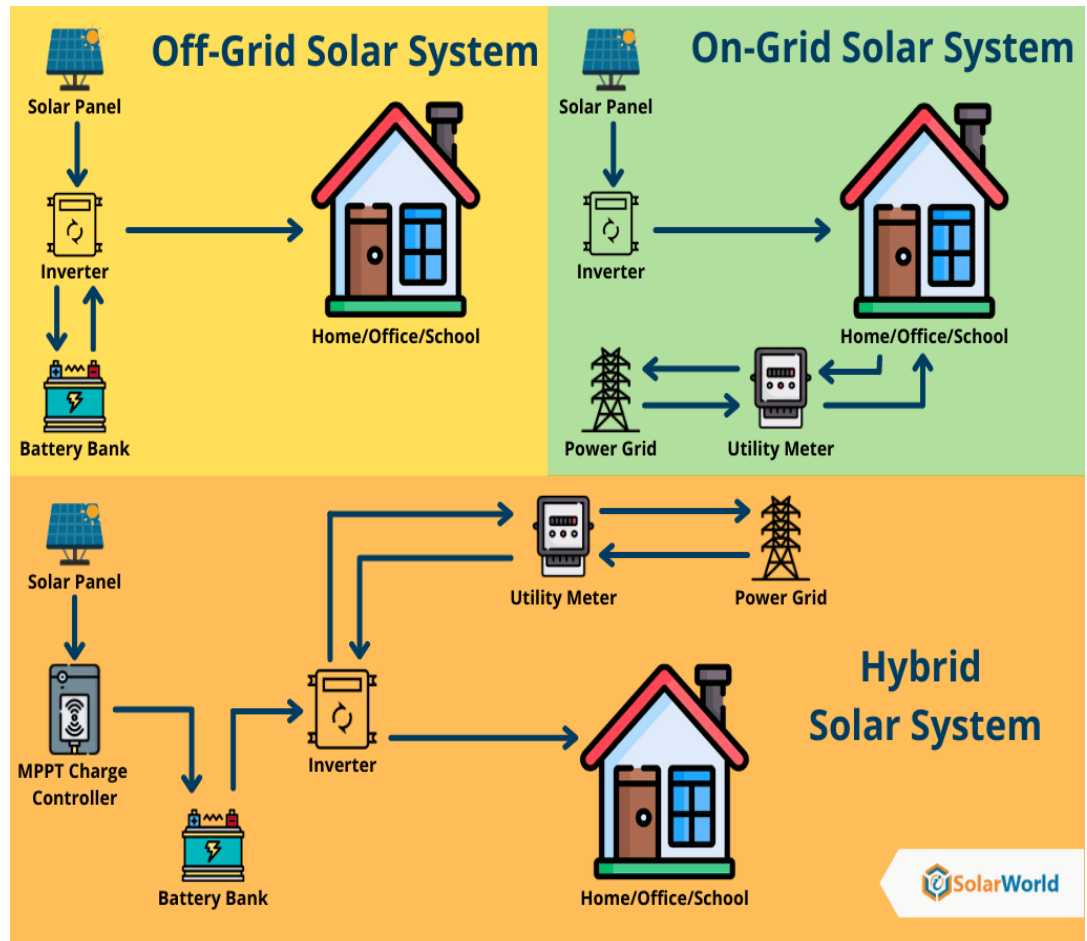

[Chapter 3 : solar cells](#)

[a- Definition solar cells](#)

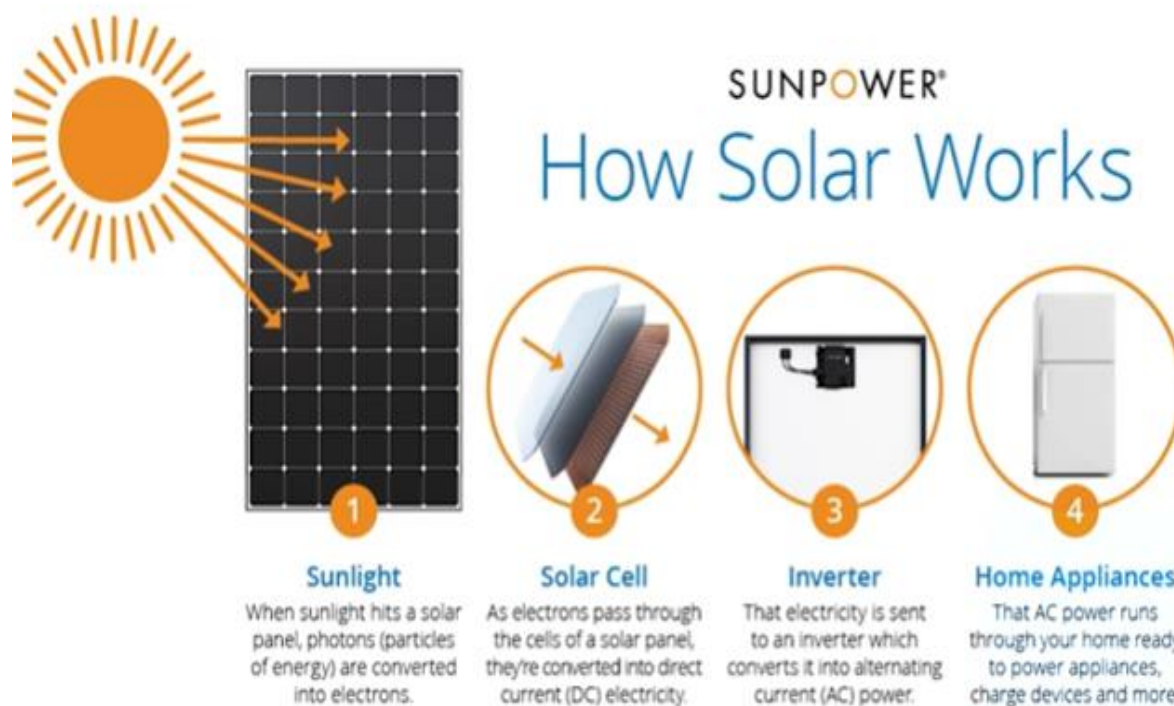
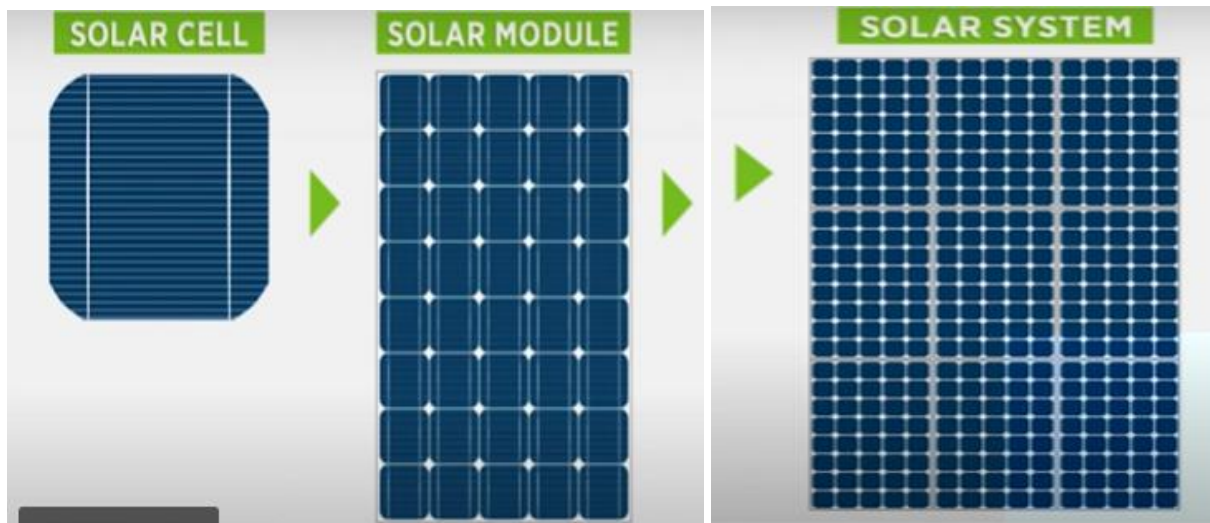

- Solar panels are a group of solar cells, and solar cells are also called photovoltaic cells. They are cells made of silicon or other materials such as cadmium sulfide and gallium arsenate.

Solar cells convert the energy of light spectra into electrical energy through the photovoltaic effect when the panel is connected to electrical loads, so an electrical current circulates in the cables and this load is fed with electrical current.

The efficiency of solar cells that convert incident solar energy into electrical energy depends on the intensity of the lighting spectra, the angle of installation of the cell, the design of the cell, building materials, atmospheric temperature and the proportion of dust in the sky.

Based on the method of manufacture, they are classified into three main types, which we will explain later.



Where one hour of sunlight is enough to provide the world with energy for a whole year in the event that we were able to exploit the full energy of the solar radiation falling on the earth.

- A few years ago, the efficiency of the panels did not exceed 15%, and the panel industry developed until it reached 23%, and it continues to develop and improve. Last May, a team of researchers at the US Department of Energy's National Renewable Energy Laboratory (NREL) built a solar cell with a standard efficiency of 39.5% under the illumination of one global sun. This is the highest efficiency solar cell of any type, and is measured using standard sun conditions. "Triple-junction solar cells with 39.5% terrestrial and 34.2% space efficiency enabled by thick quantum well superlattices," which appears in the May issue of the journal Joule.

photovoltaic (PV) technologies.

This work informs research and development by identifying drivers of cost and competitiveness for solar technologies.

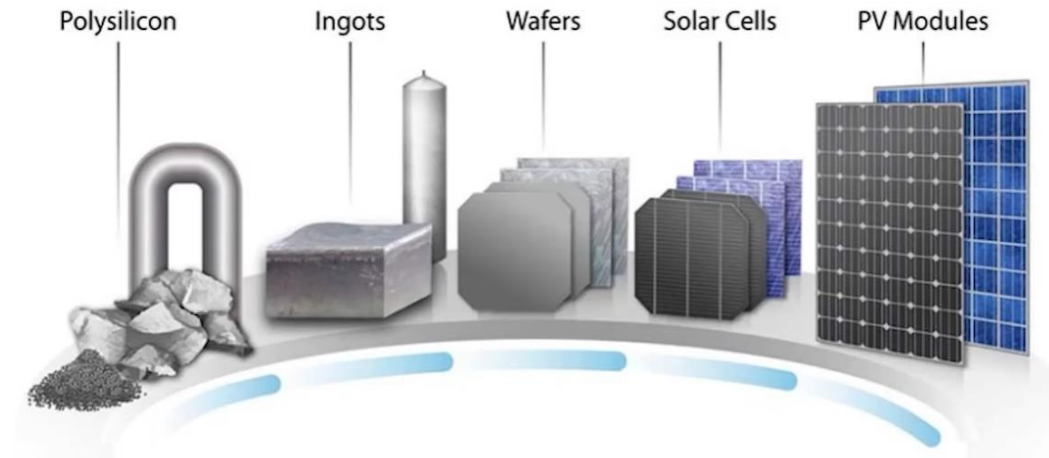

NREL analysis of manufacturing costs for silicon solar cells includes bottom-up cost modeling for all the steps in the silicon value chain.

- Where 95% of the cells on the market are made of silicon, and they are manufactured using different techniques, the best of these techniques

Interdigitated back contact (IBC)

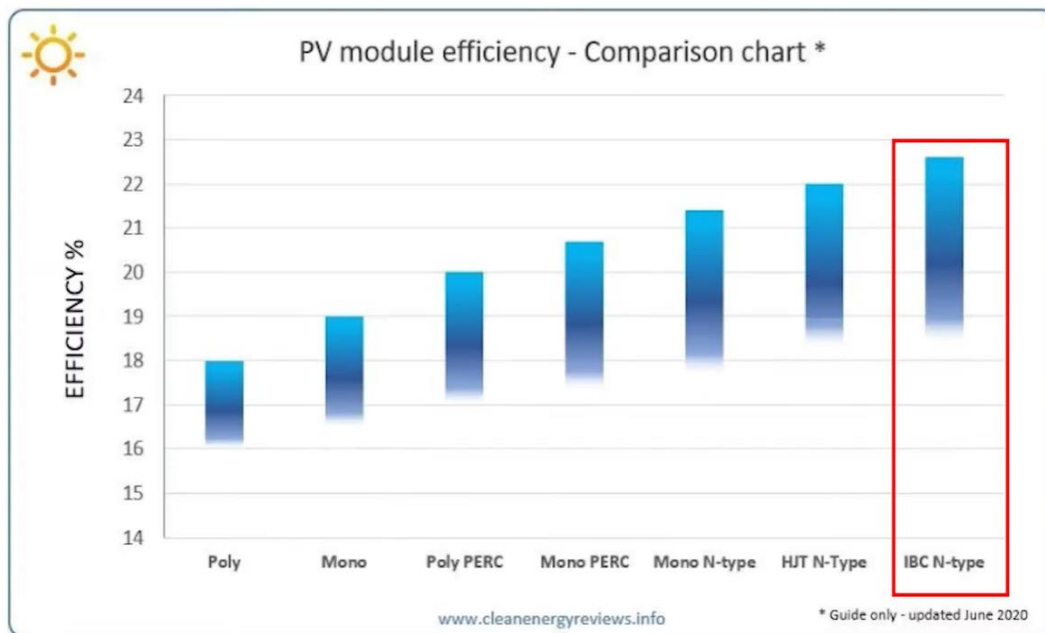

* Approximate average solar PV cell efficiency comparison chart - Mono and poly silicon types

There are different techniques such as

Back Surface Field (BSF) solar cell technology

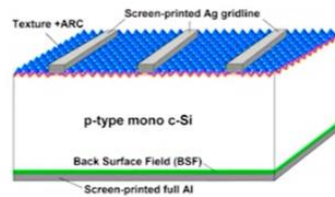

Back Surface Field (BSF) has been used as one of means to enhance solar cell performance by reducing surface recombination velocity (SRV). One of methods to produce BSF is by introducing highly doped layer on rear surface of the wafer.

Screen printed Aluminum and rapid thermal alloying are used together in order to get an Al back surface field (Al-BSF) that can lower the effective back surface recombination velocity. This process has been combined into a high efficiency, laboratory fabrication and a high throughput, industrial process to achieve such solar cell efficiencies in excess of 19.0% and 17.0%.

The critical process requirements for optimal formation of Al-BSF are:
Using of a fast ramp rate to reach the alloying temperature
Thick film Al deposition preceding the alloying

The common approach for providing the p-contact for industrial p-type silicon solar cells is using Aluminum alloyed screen printed and fired rear contact.

Passivated Emitter Rear Contact (PERC) solar cell technology

To improve the number of photons that are captured by a solar cell, PERC technology adds two additional layers at the rear of the cell.

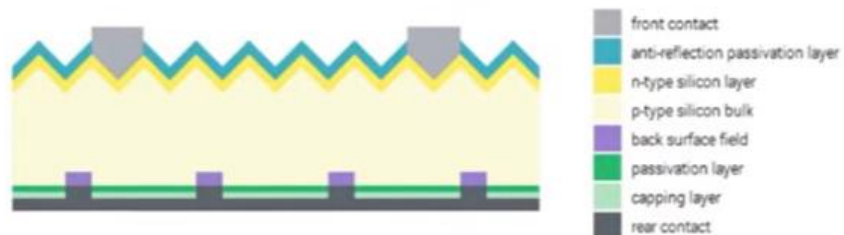

PERC solar cell

Heterojunction Technology (HJT)

Tunnel Oxide Passivated Contact (TOPCon) solar cell technology

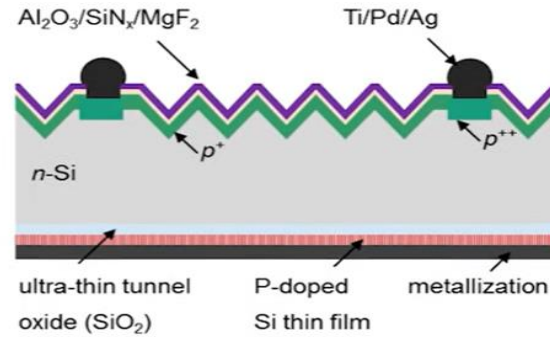

There's that word "passivated" again. In fact, TOPCON technology is basically just the next generation of PERC, and like its forbear, it can be added to cells manufactured in the traditional way. TOPCon involves adding an ultra-thin layer of silicon dioxide (SiO₂) and a layer of polycrystalline silicon doped with phosphorus.

Because TOPCon is the next logical step after PERC, it does not add a great deal of additional cost to the finished product. It can produce additional gains in efficiency over PERC, but its theoretical maximum efficiency is 23.7%. It's important to note that current TOPCon technology tops out at a little over 22%, though.

- The team at the National Renewable Energy Laboratory is working on manufacturing solar cells that are different in their material structure from silicon cells, which account for 95% of the solar cell market. These cells are called (Inverted metamorphic multijunction (IMM) cells), It is made of three layers, in order, as shown in the figure

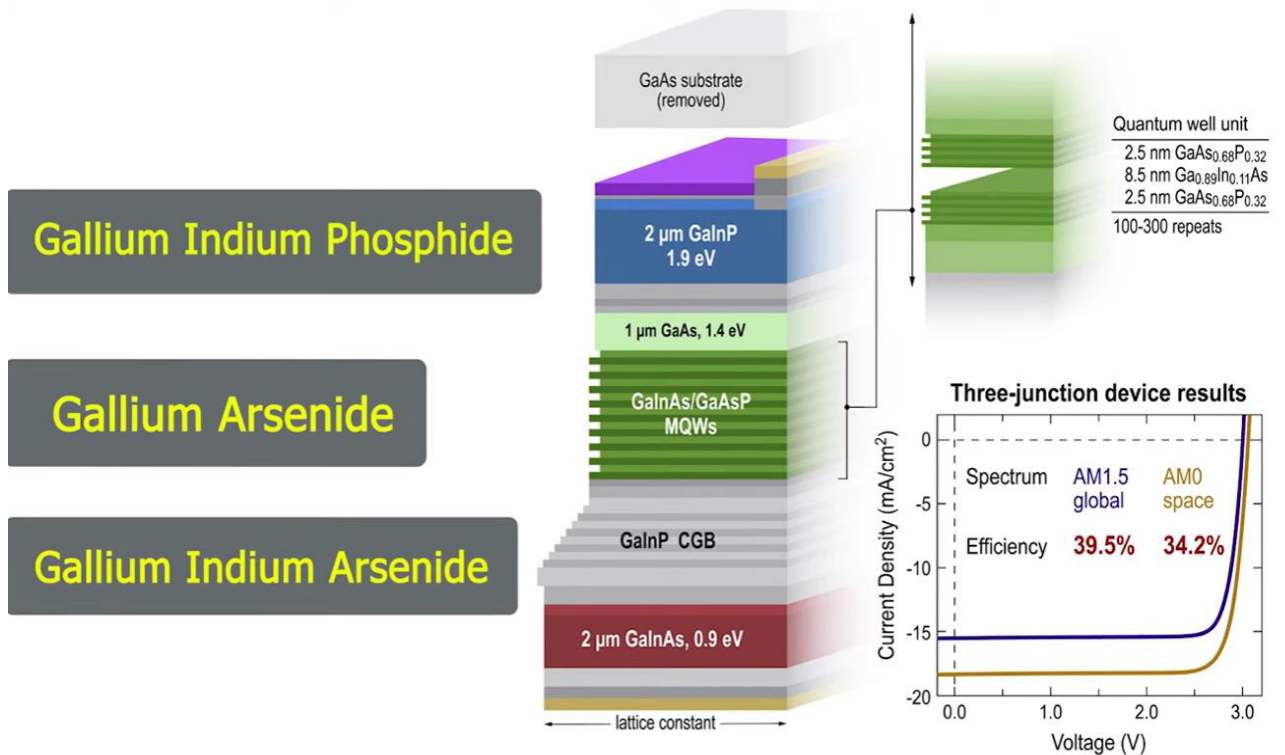

In May of this year, the team conducted an experiment to perform these cells (imm cells) and their efficiency reached 39.5% in operating conditions that simulate reality, and they also simulated their performance in space and their efficiency was 34.2%.

In 2019, the team had reached the development of solar cells, the efficiency of which reached 47.4%, but when exposed to a very focused light that is different from reality, and therefore modern imm cells are considered the cells that have achieved the highest efficiency so far in operating conditions that simulate reality. The technique used in developing these new cells depends on enabling the cells to absorb different wavelengths of light. The cell contains three layers like what we mentioned earlier, and each layer specializes in absorbing different wavelengths of light.

The other technique that contributed to increasing the efficiency of these cells is a technique called (quantum well unit), and this is done in the middle layer of cells, and this technology enhances the ability of cells to absorb light and thus increase the efficiency of the cell. Where the silicon cells available in the market absorb visible light only.

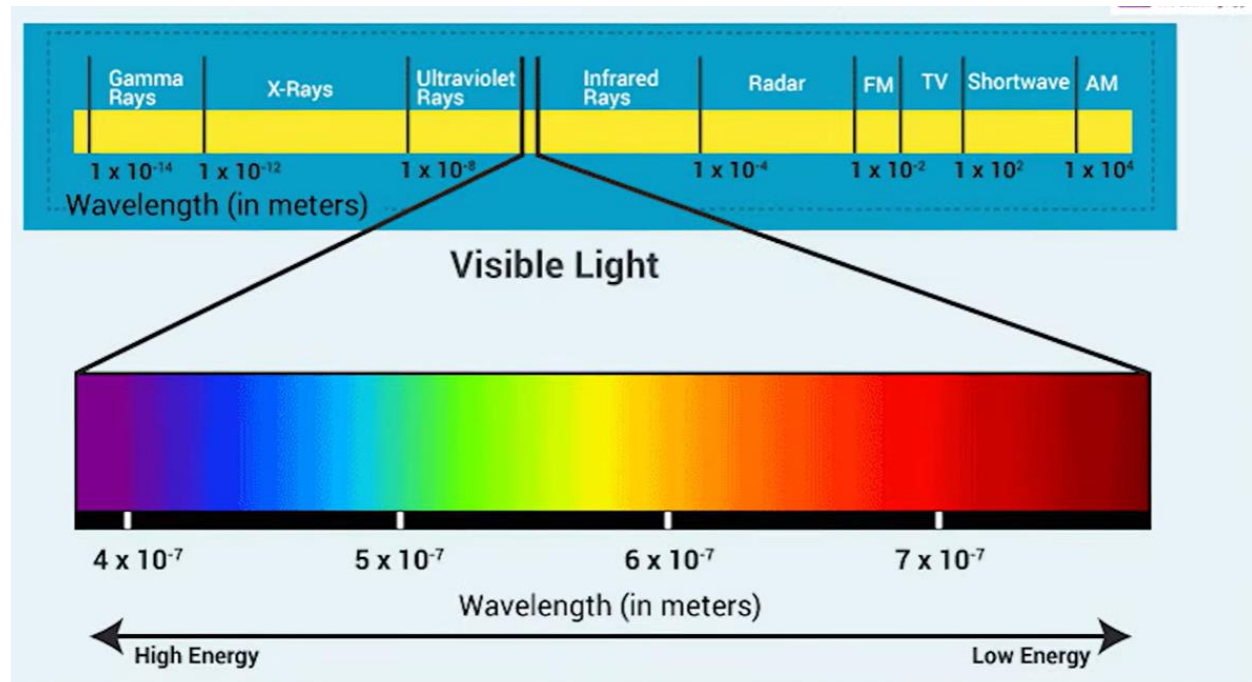

- The light spectrum is divided into two spectrums:
 - 1- First, the visible spectrum, which constitutes a small percentage of the entire visible spectrum, for example, silicon cells that absorb visible light only and do not benefit from the rest of the light spectrum, and this is what makes their efficiency low for imm cells .

2- The invisible spectrum, for example, IMM cells that absorb light of different wavelengths that fall within the visible and invisible spectrum.

- The achievement in this development is very important in the development of the solar energy sector, but there are still many obstacles, such as the high cost of manufacturing these cells, which makes them lose competition with the cells currently in the market despite the large difference in efficiency, but if a way was found to manufacture these cells This will lead to a quantum leap in the solar cell industry .



- The efficiency of the panels is calculated through the following law

☀ Solar panel efficiency % *

$$\text{Efficiency (\%)} = \frac{P_{\text{max}}}{(\text{Area} \times 1000\text{W/m}^2)} \times 100$$

* at STC = Irradiance 1000W/m²

- P_{max} = Max panel power (W)

- Area = Panel area (m²)

The relationship between the efficiency and the area of the plate is inverse, if the efficiency increases, the area decreases and vice versa. Thus, the installation costs, the required space and the connection costs are reduced, and thus the cost of the project decreases in the event of an increase in the efficiency of solar panels.

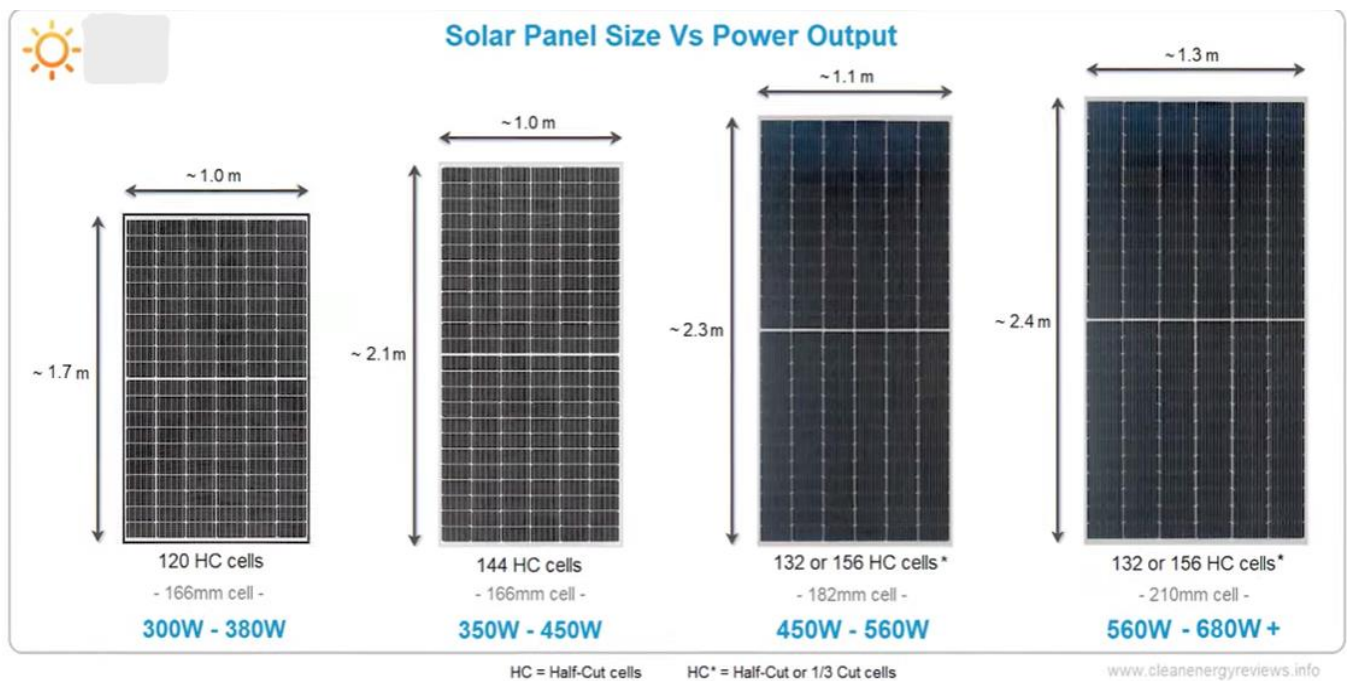

[b- Types of solar cells and their comparison:](#)

There are three main types that are classified according to the solar panel manufacturing process:

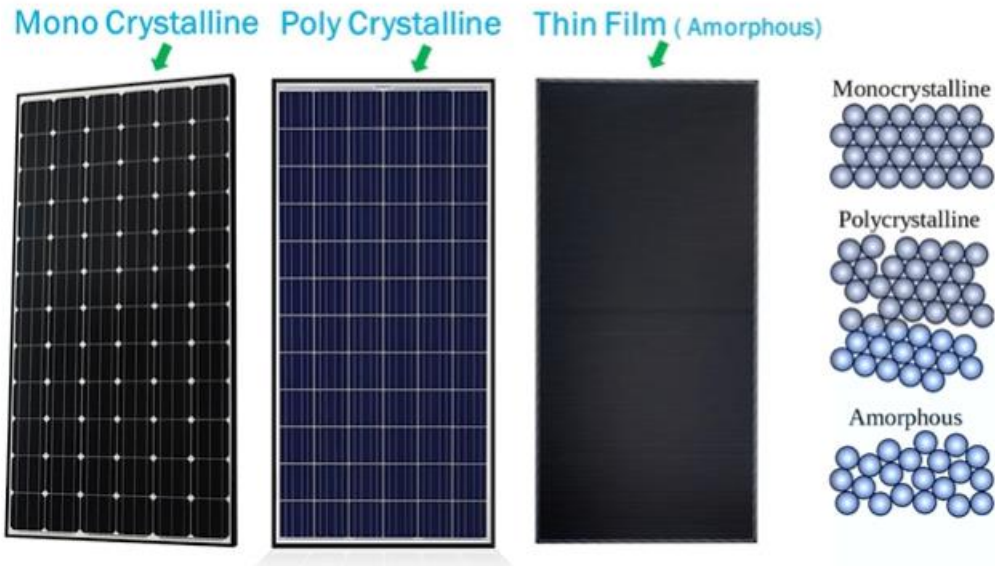

Each type is distinguished from the other in terms of performance and efficiency, in terms of quality, and in terms of its suitability for operating conditions such as high temperatures or not.

1-The first type is called mono crystalline:

This type is manufactured in a complex way and is the most difficult in terms of manufacturing, and it is called monocrystalline i.e. the silicon material from which this board is manufactured is monocrystalline and therefore produces a board that is highly efficient and expensive and we can distinguish this type from the rest of the boards by its shape where the cells in it are in the form of eight , It is also the most available in the market.

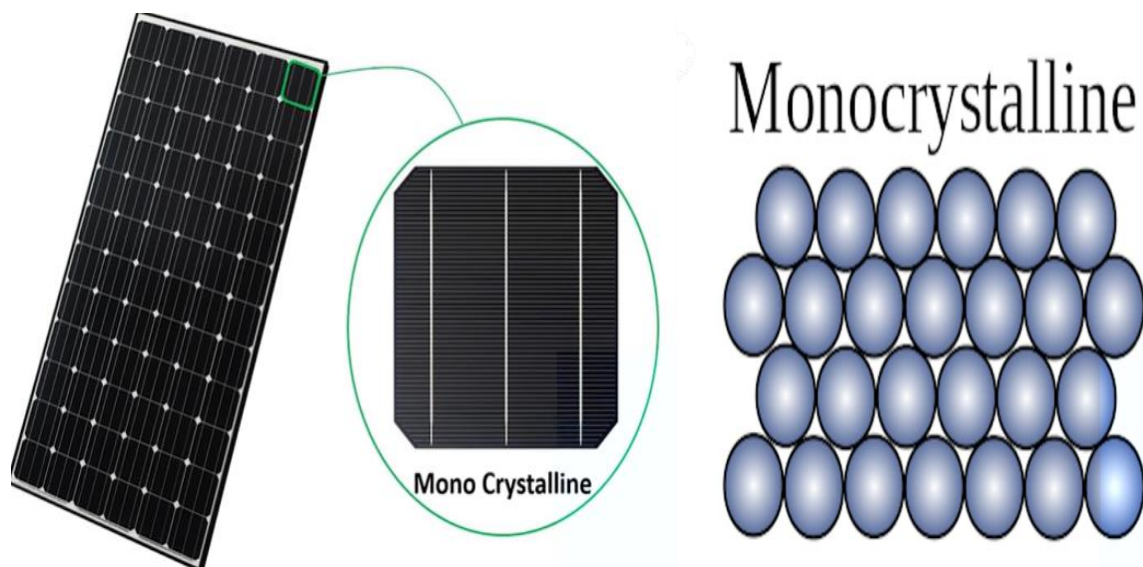

2- The first type is called poly crystalline: In this type the cell is in the form of a rectangle, and this type is made in such a way that it makes the silicon atoms that make up the solar cells be multicrystalline and the way it is manufactured is easier than the first type and its performance is less and its efficiency is less but it is not far from the previous board by much

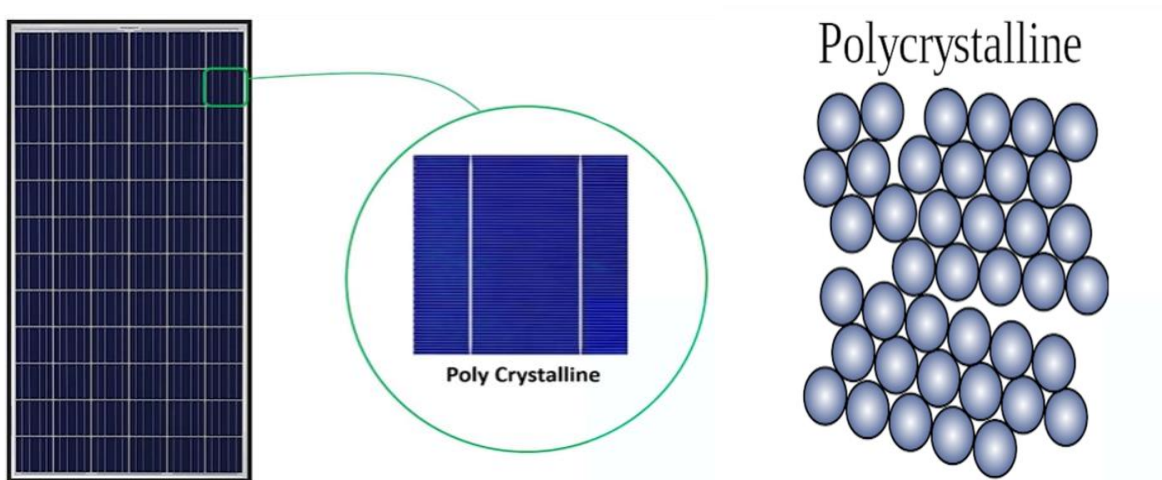

3- The first type is called Thin film :

Or known as Amorphous, this type is considered the easiest in terms of manufacturing and the atoms of silicon material in it are irregular in shape, i.e. amorphous, and also its shape is rectangular and differs from the second type in that it is black, and comes in last place in terms of efficiency and quality. It is the ideal option for those who have a lot of space and are looking for low-cost panels, which are lightweight for those who have a surface that does not withstand high weights. It is also the flexible type that you can form and put on many products. And with many features, it is the least efficient type.

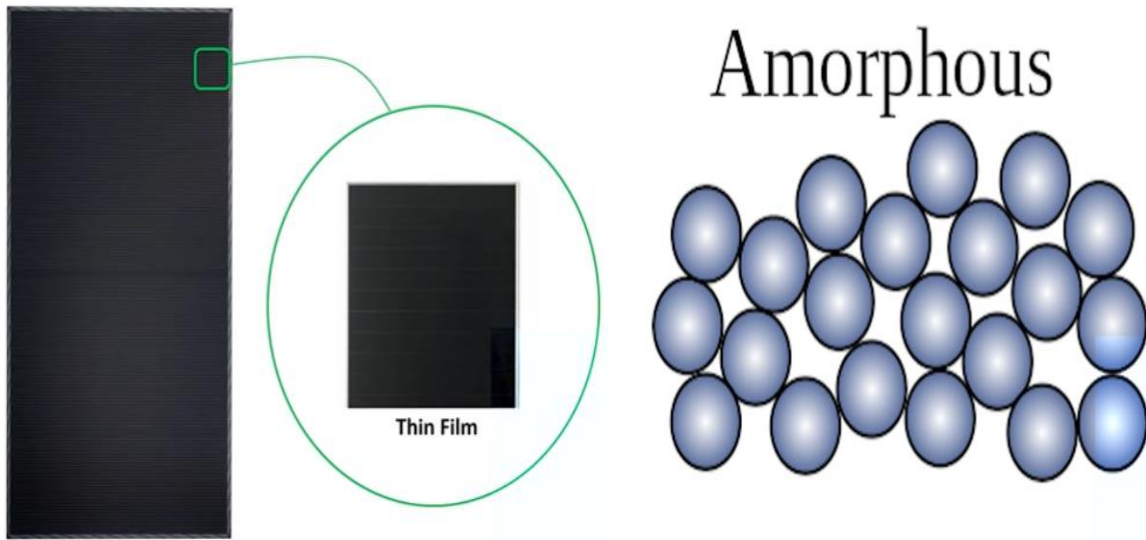

c- Characteristics of solar cells:

- **About solar radiation, the types of solar radiation, and how it falls on solar panels before mentioning the types of solar panels , There are several types of radiation including:**

Direct rays are called direct Sunlight .

And the rays that fall to the ground and reflect on the plates and are called reflected radiation(albedo) . Rays hit clouds, reflect upwards, part of which is reflected down and reaches solar panels. Other rays collide with dust particles or water molecules in the atmosphere and are also reflected upwards and part of them are reflected down and reach the solar panels .

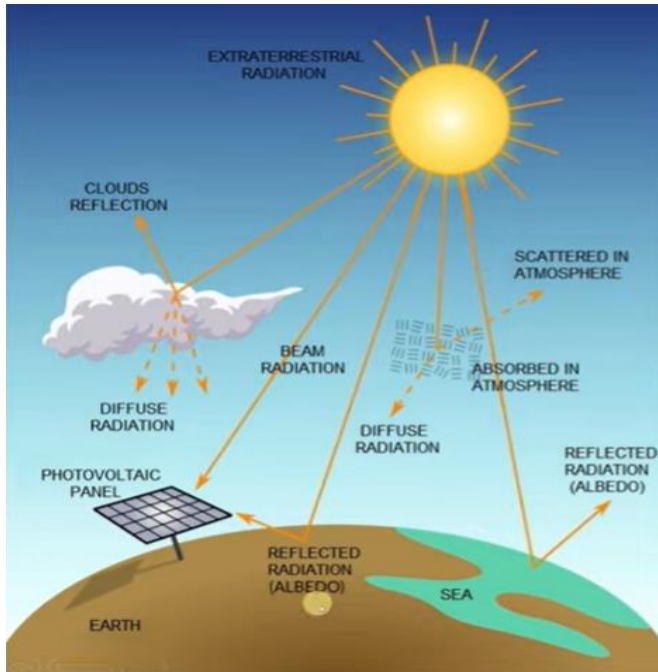

- There are two characteristics or advantages of the types of solar panel :

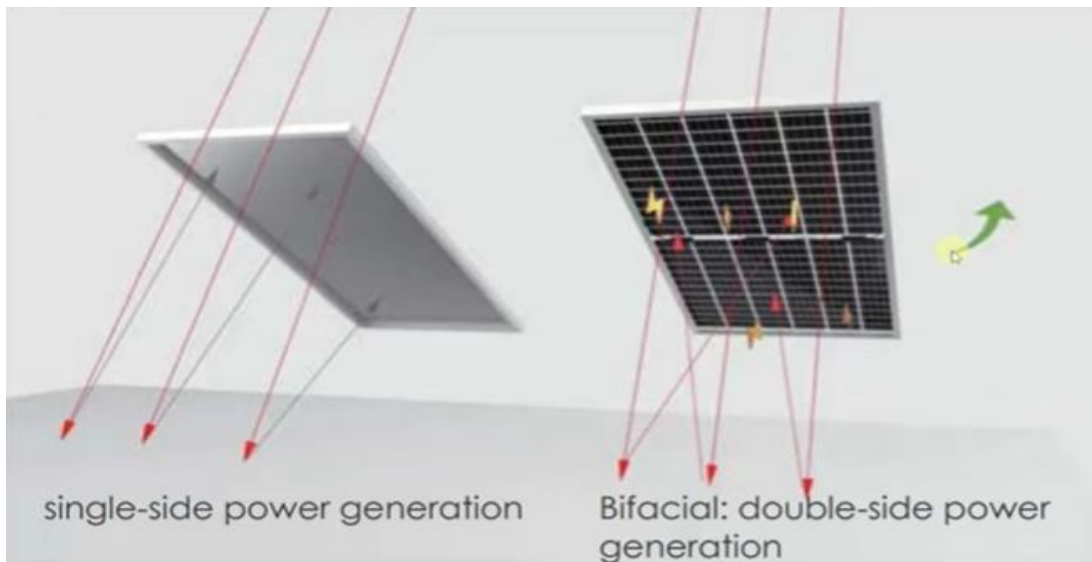

1-The first mono facial(single-side power generation) :

- They are called single-sided panels. The cells inside the solar panels receive the rays that fall directly on them through the front face. Where the back face has a white back plate made of polymer material, and this material is opaque, so the reflected solar rays cannot reach the solar cells from the back end.

Mono-facial

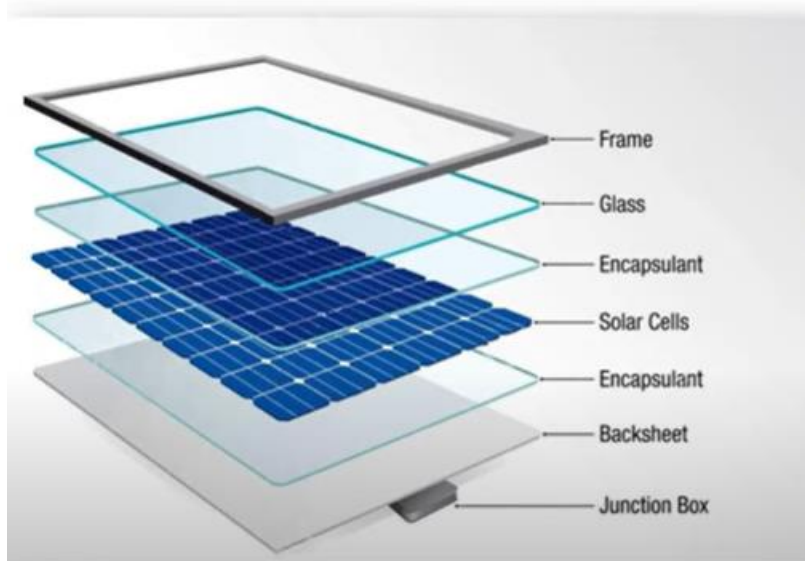

- This type of panel consists of several layers: first the frame is in the upper layer of aluminum so that we can mount and carry the panel as well as protect the panel.

Secondly, under the frame there is a layer of transparent glass where the light can pass comfortably inside this material, and thirdly under the glass layer there is a layer of insulating and transparent material at the same time called a packaging material, and its function is to stick the solar cells to the glass layer, in addition to insulation and protection .

Fourth, the layer of solar cells is under this insulating layer, and also on the opposite side of the solar cells there is a layer of an insulating material called an encapsulant.

Fifthly, under this insulating material there is a layer of polymer backsheet, which is very important for protection and electrical insulation. And sixth, after it, comes the junction box at the back of the panle .

2-The second type type bifacial (double-side power generation):

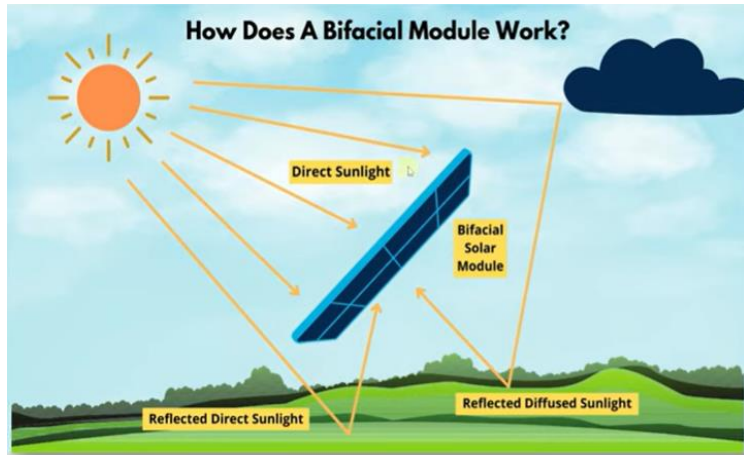

- They are double-sided panels , Different from ordinary single-sided solar panels in that they benefit from reflected rays, where the greater the amount of solar radiation falling on the panels, the greater the productivity of these panels.

Thus, double-sided solar panels receive more solar radiation if they are fixed in certain ways by the reflected rays, including those rays reflected directly from the ground, or those rays that are reflected from clouds, or particles of water and dust or whatever, they are scattered on The earth is then reflected on the solar panels, so its intensity is less and its density is lower, but it reaches the solar cells through the back face of the solar panels; Because the double-sided panel is transparent from the back and therefore the rays can reach the solar cells inside the solar panel and thus increase the productivity of these panels.

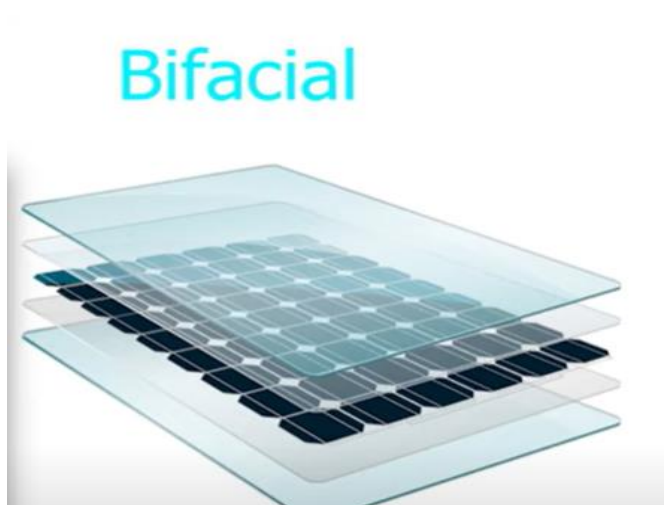

- This type of panels consists of the same components as regular panels,

But it differs from it in that it does not consist of frame material, as some of it comes with frame and some of it is frame less.

Also, the back layer is replaced by a layer of glass, where the panel becomes composed of two layers of glass, a layer at the top and a layer at the bottom.

The panel is transparent on both sides, as there is no frame, so the reflected rays can reach the solar cells from the back with ease.

And because there is a glass layer on the back, this type of panel has a higher weight.





- It can be installed in corridors and on awnings where it gives an aesthetic shape and can be installed in all positions vertically, horizontally and at an angle of 90° .

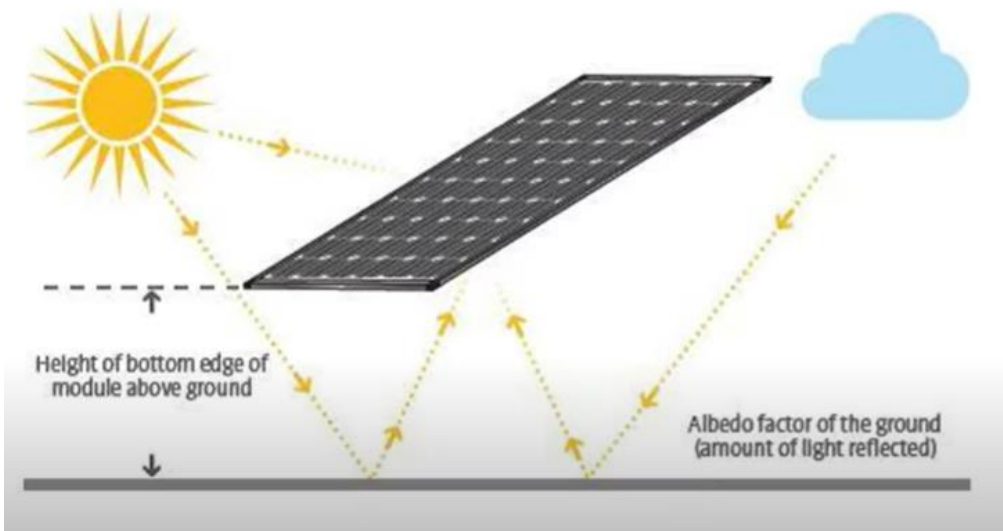

- In order for this type of panels to produce more energy, it must receive more radiation. Therefore, the panels must be installed at a height of from 120 cm to 150 cm. The higher it is, the more radiation can reach the cells from behind the panel and thus give greater energy productivity , This installation method adds additional costs .
- Double-sided panels are the ones that benefit from the reflected rays, but the nature of the surface on which the solar radiation falls and is reflected from it plays a big role. Where the amount of reflected rays depends on the type and color of the surface.

This table shows the percentage of radiation that reaches the panels according to the nature and color of the surface:

Sample Albedos of Earth

<u>Surface</u>	<u>Typical albedo</u>
Fresh asphalt	0.04
Open ocean	0.06
Worn asphalt	0.12
Conifer forest (Summer)	0.08, 0.09 to 0.15
Deciduous trees	0.15 to 0.18
Bare soil	0.17
Green grass	0.25
Desert sand	0.4
New concrete	0.55
Ocean ice	0.5–0.7
Fresh snow	0.80–0.90

Advantages :

- 1 - Efficiency is higher than ordinary boards (single-sided)
- 2 - Its durability and hardness are higher due to the presence of a glass layer that protects it from the back .
- 3 - Aesthetic shape, which gives more aesthetics when it is installed on umbrellas as well as on open corridors .
- 4 - Better performance in cloudy weather, where cloudy weather has scattered rays, there is no direct rays, only scattered rays , Ordinary single-sided panels can only benefit from direct rays .
- 5 - lower backtracking level (degradation).

Disadvantages :

- 1 - Higher cost of purchase
- 2 - Higher cost when installing, in terms of installation rules or Mounting instruction .
- 3 - special conditions required for installation, Regular installation instructions do not fit these panels because they do not have a frame so that you can install them in the usual way .

- The solar panel is a group of solar cells, and the solar cells are made of silicon. The number of electrons for silicon is 14 electrons distributed over three orbits: in the first orbit 2 electrons, in the second orbit 8 electrons, and in the last orbital of silicon 4 electrons

How many valence electrons does Silicon have

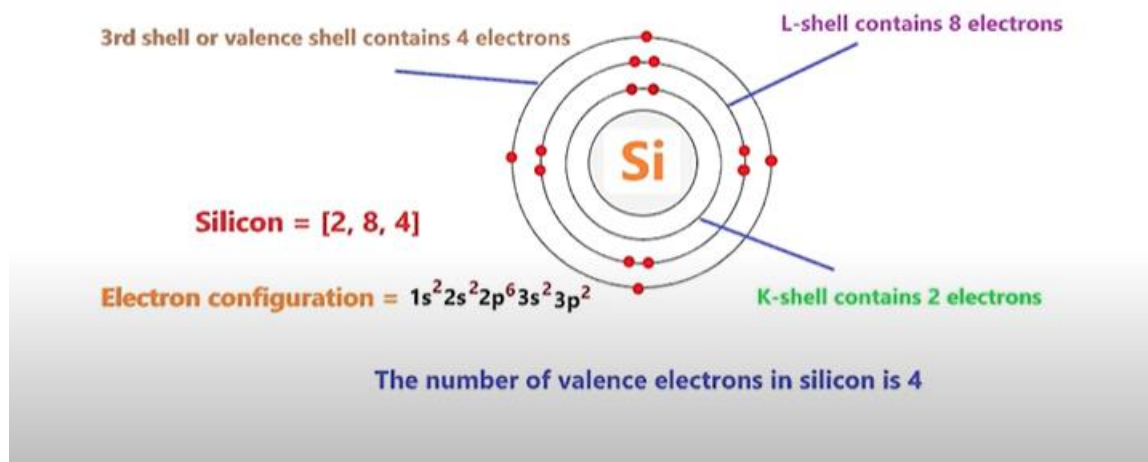

Solar cells manufactured from silicon contain a double junction consisting of two layers, the n type and the p type

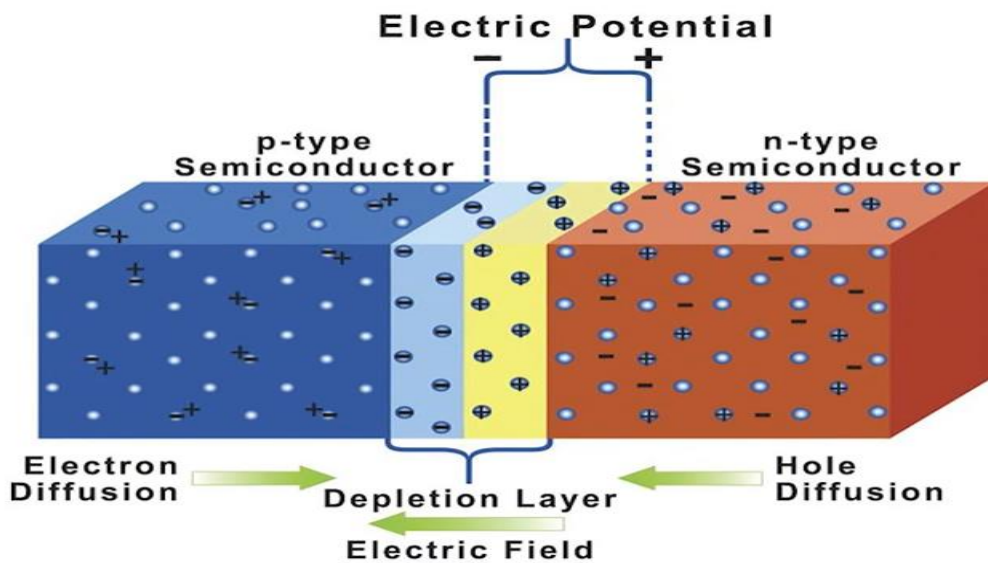

There are two most common types of solar cells:

1- cells called (p-type) : called an abbreviation for a positive type and the name comes from the fact that the bond between boron and silicon or gallium and silicon results in gaps, and these gaps are a result of the fact that boron only has three electrons in the last orbit, and four electrons from silicon are associated with it, so there remains a gap and its positive charge .

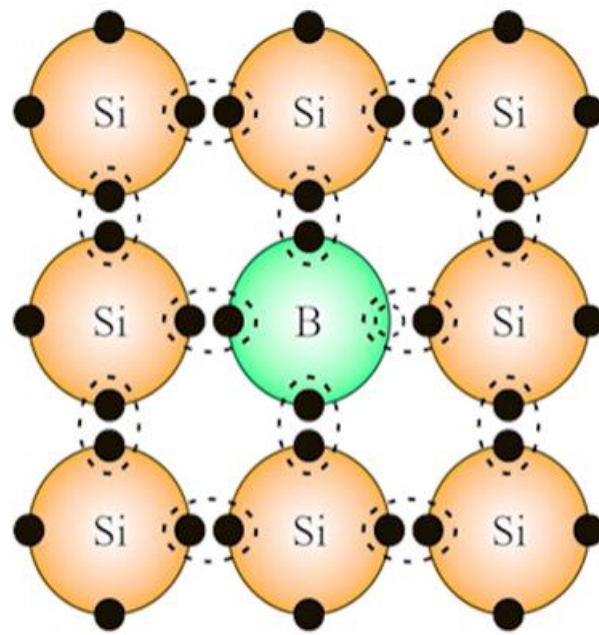
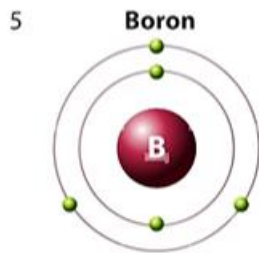
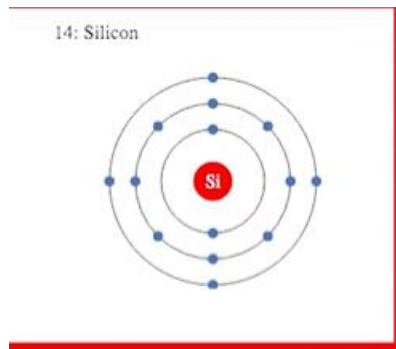

p-type

2- cells called (n-type): called abbreviation for negative type, and the name comes from the fact that the link between phosphorous and silicon results in a free electron with a negative charge as a result, because phosphorous has five electrons, and silicon electrons are associated with it, which has four electrons in the last orbit, and this

connection results in a free electron. This free electron can gain energy from light photons when the sun falls on the silicon cell, and it can move to the other p-type layer, and from here an electric current flows, and this is the basis for the work and generation of electricity in solar cells.

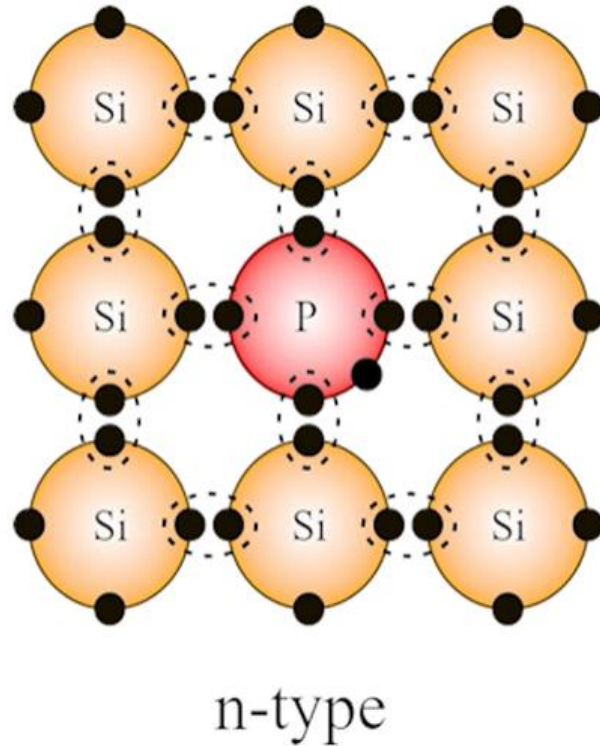
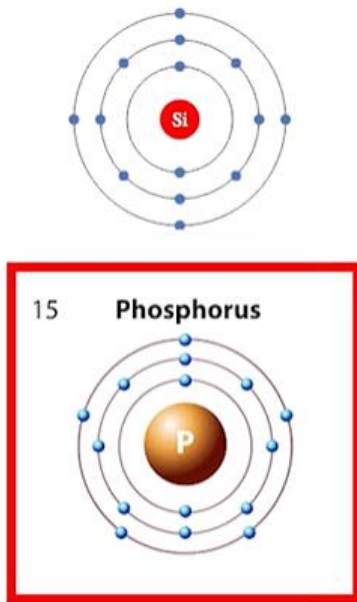

The panels are called n type if the n layer in the solar cell is the most dense and the p layer is the least dense as in the right part of the picture.

The panels are called p-type if the p-layer in the solar cell is the most dense and the n-layer is the least dense, as in the left part of the picture.



Comparison between the two types n type and p type:

	p-type	n-type
Decline in performance over time due to light-induced degradation	A decrease in production by 2% in the first year, then 0.5% annually until 25 years	A decrease in production by 1% in the first year, then 0.4% annually until 30years
Practical Efficiency	The highest efficiency is 21.9%	The highest efficiency is 22.8%
Manufacturing cost	(Standard) because it is the most widespread in the market for decades	Increase in cost due to companies' need for new production lines
Warranty on the product	15 years	20 years
Warranty on production	25 years	30 years
Temperature coefficient	0.34	0.30

Bifacial factor	Its productivity is less than the n type	Its productivity is higher than the p type
------------------------	---	---

We used p-type cells, due to their common availability in our country and n-type cells not being available, since the cell systems we studied are small and do not need a large number of plates, and therefore we do not feel much difference between them in small projects.

- Panel manufacturing techniques to mitigate the impact of shade on solar panels

There are two technologies for manufacturing panels and how they affect the efficiency of the panels to mitigate the effect of shade on solar panels:

The first: Normal manufacturing technique:

It is the first technology for cells, where a diode is placed at the bottom or top of the board, which works to isolate the string of cells (strings) that may be affected by the shadow from the rest of the strings in the panel .

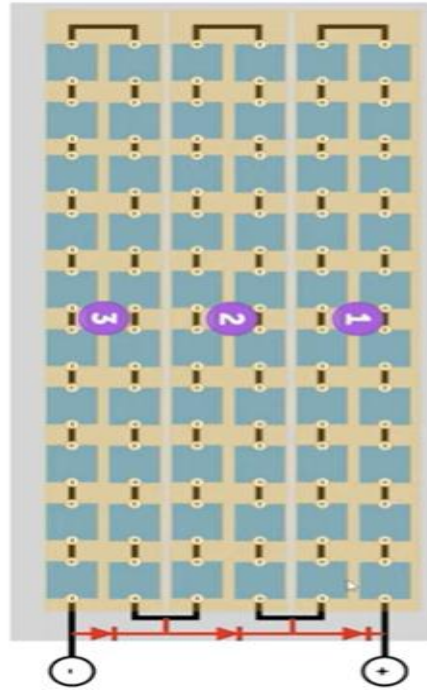

The second: Half-cut manufacturing technology:

the same as the normal method, but the cells are cut in half, and the number of cells becomes twice the number of cells in regular panels; The reason for this process is to reduce the resistance to the passage of current in each cell, and in this way we reduce the loss of power loss and raise the efficiency of the solar panels.

This technique helps to mitigate the effect of the shadow, where in the middle of the board is placed a bypass diode, which works in order to isolate the cell chain (strings) that may be affected by the shadow from the rest of the strings in the board.

The cells are connected at the top of the board in parallel with the cells at the bottom of the board, where there are two times the strings in the regular boards, where if a shadow falls on one of the cells, the diode will separate the connected string consisting of cells affected by the shadow only, and the rest of the strings will produce energy.

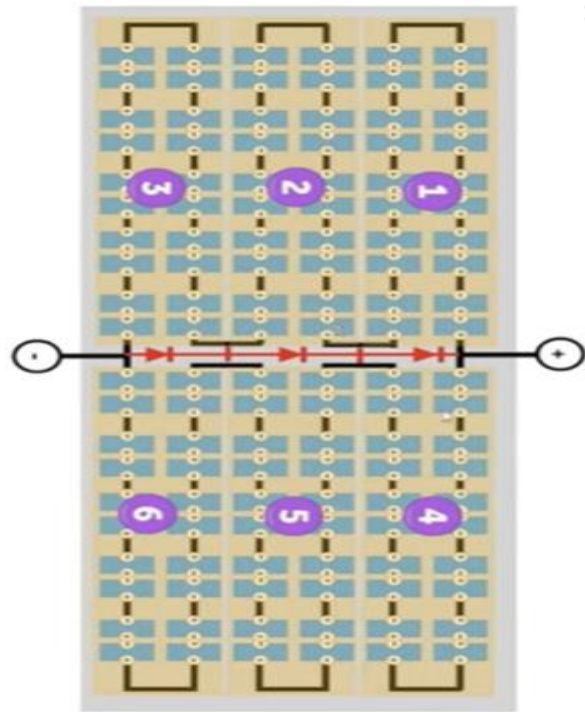
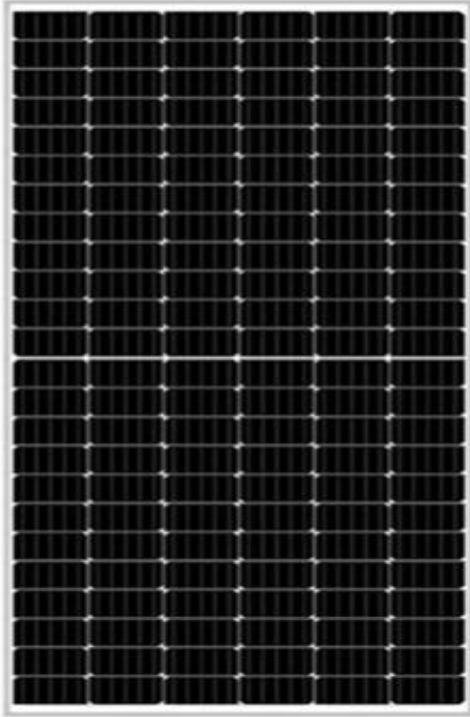

- In our project, we will make sure to use panels that have the following specifications
 - 1- Monocrystalline
 - 2- Half-cut
 - 3- TopCon
 - 4- P-Type

Chapter 4 : Characteristics of converter and charge control and batteries :

Part 1: Definition of the dc to AC inverter and ways to connect it with the rest of the system

The definition of the Dc to Ac inverter and ways to connect it with the system.

-
why do you need an inverter for solar panels.

An inverter is one of the most important pieces of equipment in a solar energy system. It's a device that converts direct current (DC) electricity, which is what a solar panel generates, to alternating current (AC) electricity, which the electrical grid uses.

When people think about solar power, the first thing they think about is the large panels fitted to the roof. However, the large sheets are not the only thing you need to convert the sun's energy into power. For your household to use the power of the sun. It must go through an important component of the solar system – the solar panel inverter.

An inverter is an absolute must for a solar system. It's responsible for the conversion of power collected by the panels into a current that is safe to use. To understand the importance of a solar inverter. You must first understand the entire solar process. How does a solar inverter work?

Collection

- The process begins with the panels. Comprised of a silicon material that converts the sun's energy into electrical power. The panels then collect the energy from the sun.

- The panels collect the power throughout the daylight hours.
- The individual panels then combine the collected power and send the DC to the inverter.

Inverting

- In the form of a small box, some inverters record the efficiency of the panels. This gives you a specific gauge on how much power you collect from the system.
- The inverter, which in the case of a central inverter is often fixed out of the way on the side of a business or home.
- The vast majority of home appliances such as TVs, fridges and lights run off of alternating current (AC). So, the solar power inverter's role is to transform the DC into the necessary AC for everyday use in the home.
- Some systems use micro-inverters rather than a single central inverter, which attach to the underside of each panel. These collect and transform DC and convert this power to an alternating current. However, these options are more expensive.

Function

- Once the inverter creates the correct power input, it sends it to the fuse box and to the building.
- When the switchboard receives the AC, the home receives it to power all of the appliances as required.
- From the fusebox, excess power is either sent to a battery storage system or back into the grid, depending on your usage and system set-up, this will vary.

The inverter is crucial for the conversion of the energy collected from the panels to a power source. The solar inverter system works as a middleman, and without it, the power collected by the panels would be worthless.

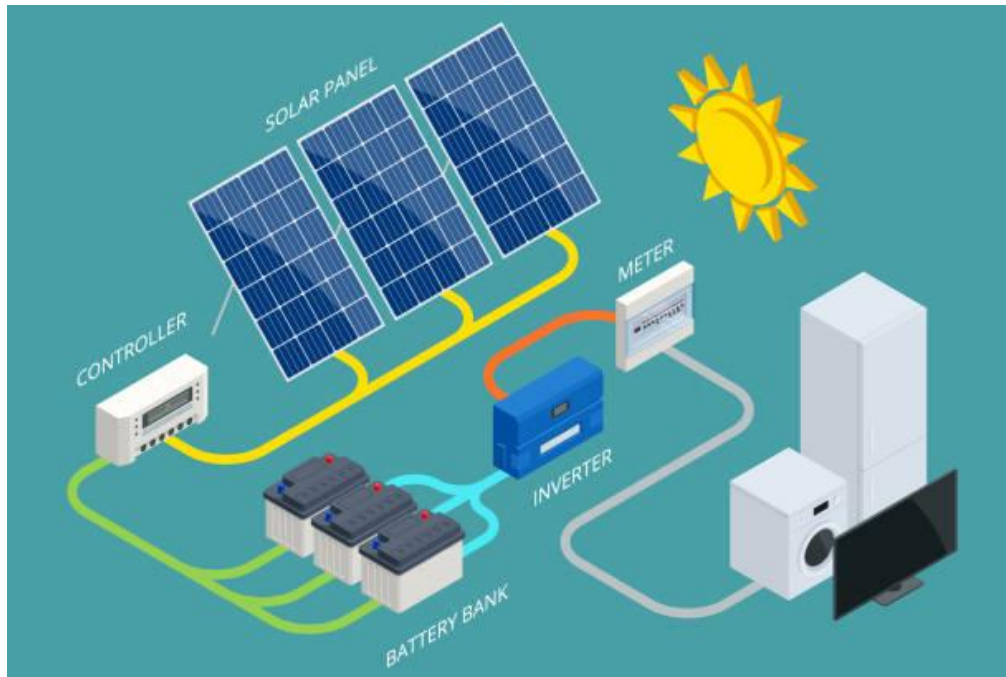

Why Do Solar Cells Need An Inverter?

Solar cells require an inverter because their DC output needs to be transformed into AC. The main reason for this is that most of our home appliances need electricity in AC form to function correctly.

So, the inverter does the conversion job. It receives DC electrical energy from solar cells. Then, the inverter uses various electrical and electronic components to make the DC input oscillate at a frequency of 50 or 60 Hertz. The inverter's output is an electrical current with a sinusoidal

waveform called AC. When the solar cell's DC electricity transforms into AC, our home devices can then use it to operate appropriately.

Why Do Solar Cells Produce DC Only?

When the sunlight hits the surface of a solar cell, it stimulates the electrons to flow, which creates the current. Now, these electrons will flow in one direction only.

The unidirectional electron flow produces the DC or direct current. Therefore, a solar cell can generate DC electricity only and not AC. Otherwise, there will no longer be a need for an inverter in this case.

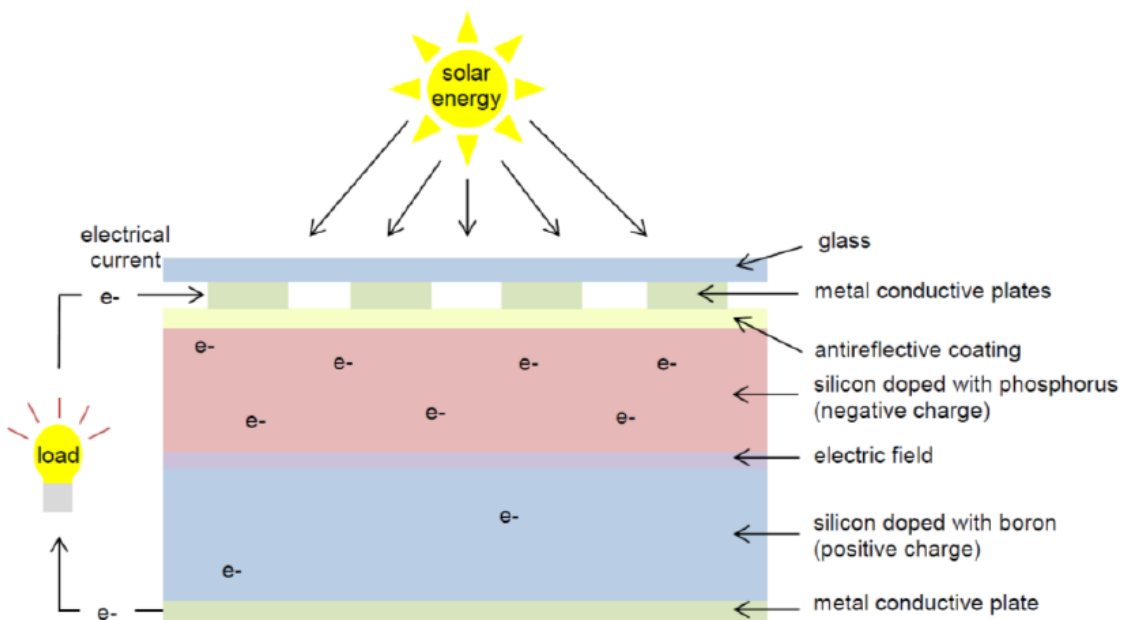

WHAT IS A SOLAR INVERTER AND HOW DOES IT WORK?

A solar inverter is the component in your solar panel system which changes the direct current (DC) electricity captured by the solar panels, into alternating current (AC). AC current is the standard flow of electricity required to power your home appliances and connect to the National Grid. It is usually equal to either 120 volts or 240 volts depending on the country. Simply without a solar inverter in your system, you would be unable to power your home safely from your solar energy.

As a solar panel system is only as efficient as its weakest part, a high quality inverter is an essential part of your panel set up. Capable of maximising the available energy being generated by your Solar Panels. The importance of inverters are often overlooked during the design stage, but not here at Deege Solar.

WHAT DOES A SOLAR INVERTER DO?

PV inverters are considered the brains of any Solar PV system. Their essential features include:

- The ability to convert direct current to alternating current.
- Maximising power output.
- Communicating with the National Grid.
- Giving feedback information about power production.
- Ensuring that your solar PV system is operating safely.

THE DIFFERENT TYPES OF SOLAR INVERTERS

There are four main types of solar inverters. String inverters, micro-inverters, hybrid inverters and power optimisers. In this blog we will explore the key characteristics of each kind of solar panel inverter. So that choosing the right solar inverter for your system couldn't be simpler.

- STRING INVERTERS



A 'string' is a chain of solar panels that are arranged into groups or rows, connected in series. In order for a string inverter to work efficiently all the panels in a string must be at the same pitch and orientation. Multiple strings can be connected to a single inverter, in fact many string inverters have 2 or even 3 MPPTs (Maximum Power Point Tracking). This means that you can have a different string of solar panels on each MPPT. This is ideal for an east/west set up, where the two strings of panels will have an unmatched solar generation.

- MICRO INVERTERS



Micro inverters are a relatively new technology, becoming a popular choice amongst home solar PV systems. Whereas as solar panel system on a string inverter is impacted by a fault or shading on a single panel, a micro inverter system solves this problem. This is because in a micro inverter system each individual solar panel has an inverter to itself, therefore isolating any issues. As a result, micro inverters are often considered as the way to install more solar panels onto a roof. As shaded areas are no longer a no go or the need for mixing orientations no longer becomes an issue. Despite being generally more expensive than your classic string inverter, a micro inverter system is set to increase your solar energy generation and therefore return on investment.

- HYBRID SOLAR INVERTERS



If you are installing a new Solar PV system with storage, then a hybrid inverter is well worth considering. As solar panels generate DC electricity, we know that an inverter must convert the energy into AC electricity in order to power your home's appliances. However, solar batteries store electricity in DC form.

A hybrid solar inverter is capable of converting the incoming DC into AC, while also sending any surplus DC power to store in a solar battery, or to be sold to the grid. When your stored energy is in demand, the electricity can then be inverted to AC to be used in your household.

Brands which manufacturer hybrid solar inverters, include GivEnergy, Solis, Growatt and Fox-Ess.

- POWER INVERTERS

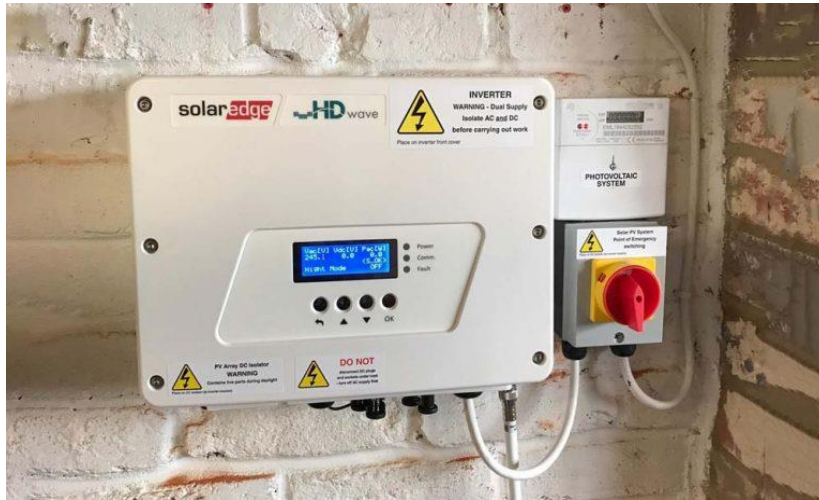

Offering many of the same benefits as micro-inverters, power inverters are also located on each individual panel. Also known as DC power optimisers, power inverters offer panel-level optimisation and performance monitoring. Unlike a micro-inverter system, instead of directly converting DC to AC at roof level, the optimiser moves the DC power through to a string inverter. Which is likely fitted next to your battery storage system. As they are at module-level they are often a cheaper alternative to micro-inverters.

SolarEdge is the market leader in power optimisers. Capable of increasing generation, identifying issues and offering arc fault detection. As a result, when you choose a SolarEdge PV System, you are choosing to generate more green power!

SO WHICH SOLAR INVERTER IS RIGHT FOR YOUR PROJECT?

Every home and commercial property requires different solar needs. It is important to choose the right solar inverter for your project. Hence why the team here at Deege Solar offer free consultations to design you with a bespoke solar panel system As MCS certified Solar Panel

Installers, with over 12 year of experience, when you choose Deege Solar you know you are in safe hands.

How to connect solar panels to the inverter?

When you have solar panels, your primary concern is to make the best use of them. As we all know, solar energy generated by the PV panels is better to not use directly but to go through the solar power inverter. So, it's important to make the correct connection between solar panels and the solar inverter. This page will help you solve the question of how do I connect the solar panels to the inverter.

1. Which wiring connection is better?

As we know, the ways of solar panels connection are in series and in parallel. But which connection is better for solar panel systems?

With the way of connection in series, the most outstanding feature is that it can increase the voltages of the whole solar system and keep the same current, while no need bigger cable to the grid. But when one of the panels gets wrong, the solar panel system will collapse unless you fix it or update a panel. However solar panel wiring in parallel connection can keep the voltage contain and increase the current. And when one of the panels works badly, the solar panel system can still go properly function but just the power will go down. The disadvantage of parallel wiring is to need multiple wires when connecting into the grid. In fact, to balance voltage and amperage for your solar array to perform at the best, many electrical applications use solar panel wiring not just in series or in parallel, but a hybrid of both in series and in parallel connection. The number of series panels depends on the voltage of the load, and the number of parallel panels depends on the power of the load. But also need to meet the solar power inverter's condition of normal operation at the same time.

2. Can I connect the solar panel directly to the inverter?

Yes, solar panels can be directly connected to the inverter instead of the charge controller. A proper and good quality solar power inverter is an essential part of your photovoltaic arrays. It's an important bridge of solar panel connection to the battery and to the grid.

The solar power inverter has four special functions:1) It can average the voltage fluctuations of the solar panels and output a steady charging voltage2) It can prevent battery overcharging and prevent backflow.3) It can convert the DC current from the solar panels into AC current to support domestic appliances and export to the grid.4) It has the function of monitoring the photovoltaic panels, the battery, the grid, and your loads with maximum power point tracking and anti-islanding protection.The solar system connection diagram is below.

3. How to connect the solar panel to the solar power inverter?

About the solar panel connection to inverter wiring steps, let me show you the luxpower hybrid inverter because the PV connection of luxpower hybrid inverter is the same as a traditional on-grid solar inverter(string inverter).

*** When connected solar panels to the inverter, take notice that:**

1) Before connecting the PV, please use the multi-meter to measure the PV array voltage to verify if the PV array is working normally, if not, please fix the PV array to normally working states before connection.

2) Inspect the PV+ and PV- output of the PV string, make sure the positive and negative poles of PV and inverter will be correctly connected.

3) When your PV panel's ambient temperature could possibly be lower than 0°, then please check the PV array voltage up the ceiling, and if you are not sure please ask your system or panel provider for further assistance.

As when the temperature is extremely low the PV panel voltage will increase by a certain percentage.

*** Solar panel wiring steps:**

Step 1: Turn off or disconnect the PV switch(DC switch). Then keep this switch always open during the connection.

Step 2: Assemble the PV connector1) Strip 6-8 mm insulation from the cable end.

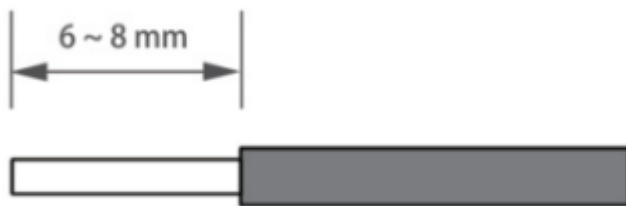

2) Assemble the cable ends to crimp contacts.

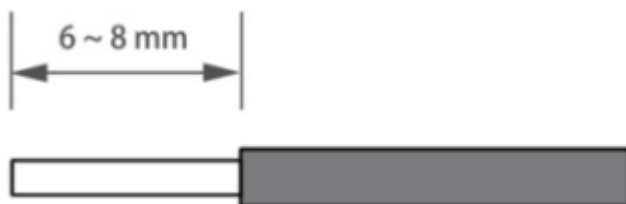

3) Lead the cable through the cable gland, then insert it into the corresponding insulator until it snaps into place, then tighten the cable gland.

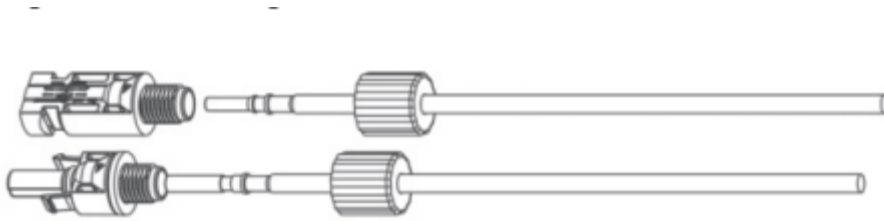

Step 3: Install the PV connector

When verified the PV connector is tight, align the 2 half connectors and mate them together by hands until 'click' is felt or heard.

How to Connect Solar Panel to Battery and Inverter

If you want to save on the labor costs of installing a solar system. It's important to understand how solar panels are wired. A proper wiring process will directly affect the performance of the inverter in the future. Avoid future system failures due to incorrect wiring. If a failure occurs because of this, we may have to pay expensive repair bills.

Series vs. parallel connection difference?

The charge controller is the most important component in solar panel wiring. Charge controllers with maximum power point tracking (MPPT) are used with solar panels in series. A pulse width modulated (PWM) charge controller is employed for parallel-linked solar panels. The solar panels in series work the same way that the electronics connected in series do. If one of the panels connected in series fails, the complete circuit will fail. Furthermore, a faulty panel or a loose wire in the parallel circuit will not affect the remaining solar panels. The type of solar panel inverter for home used today determines how solar panels are wired. We will discuss the difference between parallel and solar panels in series connections.

Hybrid Parallel Model Installation Guidance

Single Phase Parallel System Wiring

Installing a solar panel inverter for home that enables "parallel connection" allows you to link numerous inverters together. You can acquire a bigger backup power supply this way. Tell your

dealer if you require a parallel unit because the parallel model differs from the conventional model. Then we'll look at how to create a parallel system.

Step1. Single unit installation

Make sure the distance between each inverter satisfies the user manual's criteria before installing it.

Step2. Parallel system wiring

If you're paralleling your system as a single-phase system, double-check that each unit's L and N wires (AC port and EPS port) are connected correctly. Please use a multimeter to double-check that each device's L wires are connected. Make sure that the L wire of one inverter does not link to the N wire of another solar panel inverter for home.

Wiring suggestions for parallel systems are as follows for safety and cost: In this illustration, three single-phase inverters are linked in parallel. Note that just one CT clamp is required for the CT clamp in a single-phase parallel system. Any solar panel inverter for home in the system can be connected to the CT clamp RJ45 terminal.

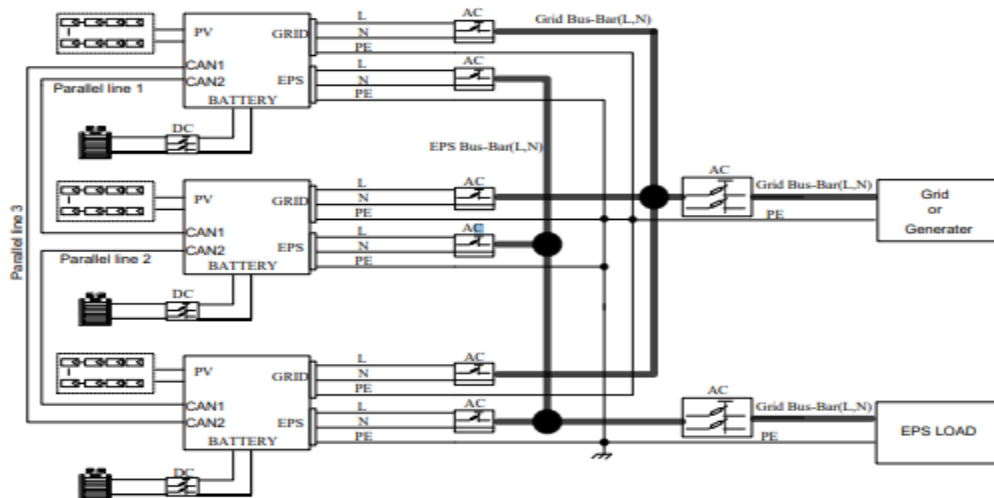

The suggested wiring:

Tips: Copper wire 1 mm² safe current carrying capacity is 5 amps (within 20 meters distance)The PE line can chosen between 6~10 mm²

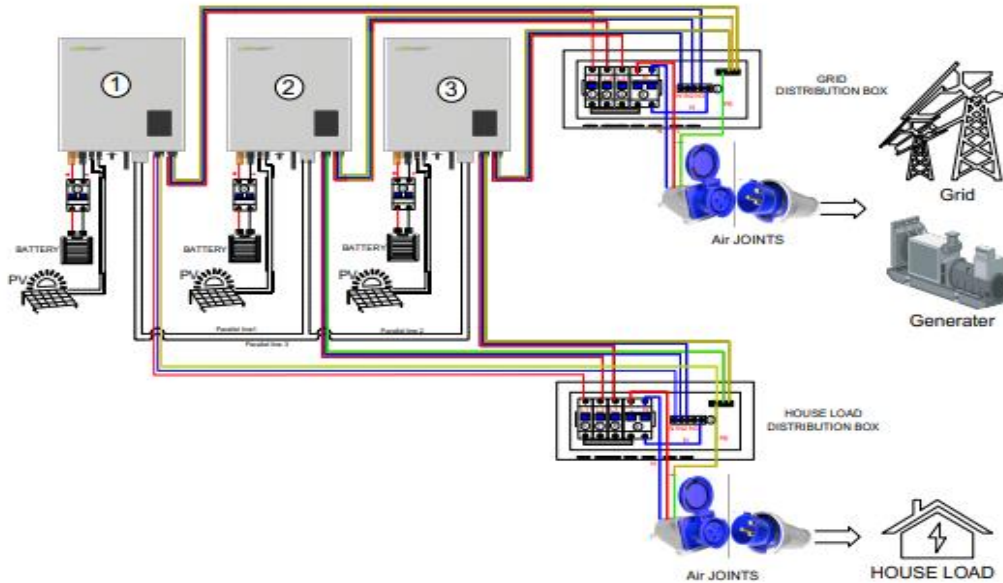

Chapter 5:batteries :

a- Types of batteries, definition, characteristics, advantages, disadvantages and comparison

There are many factors that must be taken into account when determining the appropriate battery for the system used, including the type of battery, the number of discharge cycles for it, its capacity, its price, and several features and specifications of the batteries, where we mentioned the common types used for solar energy systems and compared them in terms of the best according to their need

There are several types of batteries Used for solar energy systems, of which three types are commonly used and they are:

- Flooded lead-acid batteries
- Valve regulated lead-acid batteries
- Lithium-ion batteries

1- Flooded lead-acid batteries

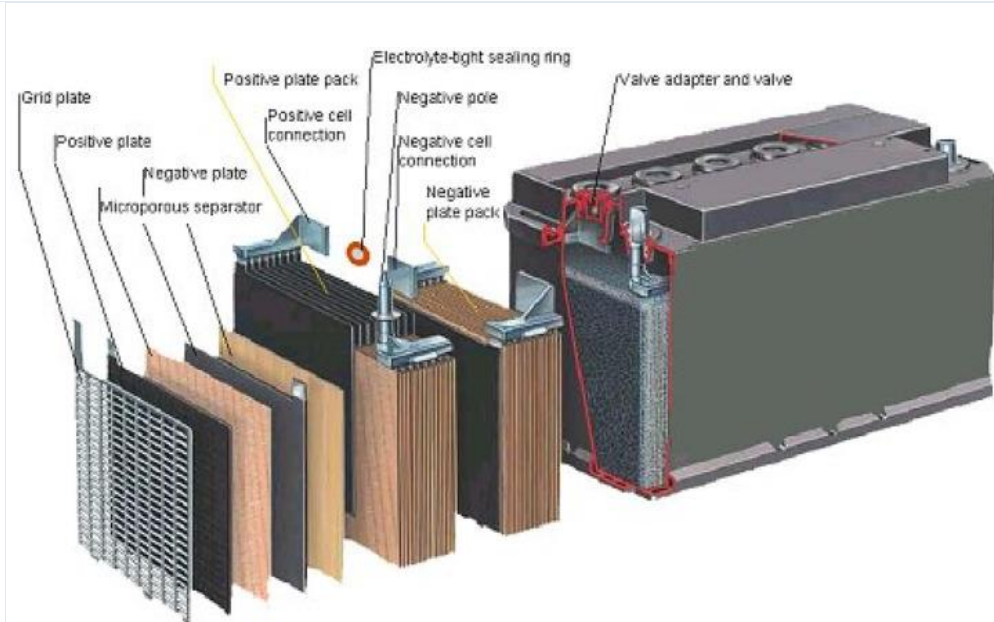

It is the oldest type of battery, and it consists of strips of lead material, and between these strips is a liquid that can ionize the electric current, and that is why it was named by this name. This type requires periodic maintenance and ventilation, so that the water level inside the battery is increased by adding distilled water every once in a while. Because of the charging and discharging process, the liquid evaporates, and the water level inside the battery decreases.

Also, hydrogen gas of this type rises with chemical reactions during the process of charging and discharging. This gas is non-toxic, but it increases in concentration. If it is highly concentrated in the place of the battery, it causes ignition. This means that this gas is flammable in conditions of high concentration and therefore needs necessary ventilation. And it must be placed in a special room or box, and a ventilation method is designed for it in order to drain the hydrogen gas

Advantages:

Lead-acid batteries are the cheapest energy storage options, which makes them more cost-effective. Plus, since the technology has been around for years, they are easily disposable and recyclable.

dis advantages:

Flooded lead-acid batteries require ventilation and regular maintenance to function properly and reduce the chances of ignition, which increases the chances of a battery leak.

This also limits how flooded lead-acid batteries can be installed, because they cannot be placed on their side. They also have a very low depth of discharge (DoD), so they have to be loaded more often.

Having a low drainage depth also means they have a short lifespan - less than 5 years.

2- Valve regulated lead-acid batteries



This type of battery differs from the first type as it does not need maintenance because there is no liquid in it, as the liquid has been treated in a certain way so that it becomes in the form of a jelly. As the issue of maintenance is important because it needs time and effort for periodic maintenance constantly, that is, it needs a person who is able to carry out the maintenance process, and the battery life will be shorter than the supposed life.

There are three types of this type:

1-The first type: it is called wet, as it is used in navigation applications.

2-The second type: called AGM (absorbed glass mat), and this liquid has been treated so that it is absorbed into a mat of glass wool.

3-The third type: It is called Gel, and it is the most famous and used type, especially in the Arab markets. With this type, the electrically ionizing liquid is treated so that it becomes in the form of a gel and thus is no longer liquid. Therefore, this battery becomes without the need for maintenance.

Advantages:

Lead-acid batteries are the largest. Lead-acid batteries are the lowest and most widely used, and China is the world's largest producer of lead-acid batteries. It contains less polluting components and can be recycled.

Disadvantages:

Small specific size and short to average life. That is, under the same capacity, the battery is heavy and bulky. The current lead-acid batteries are mainly developed from floating-type batteries. The floating battery is not suitable for fast charging and high current discharging. Although the technician has put a lot of effort into improving the product, it can be used practically, but its life as an electric vehicle battery is still not very satisfactory.

3- Lithium ion batterie

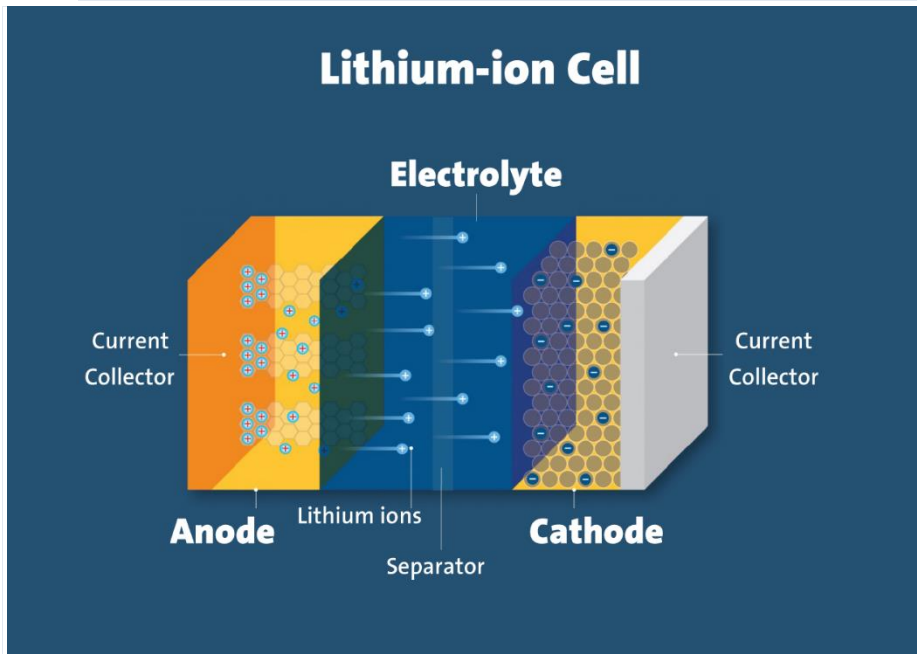

Lithium-ion batteries are the new kids on the energy storage block.

With the increasing popularity of electric vehicles, electric vehicle manufacturers have recognized the potential of lithium ions as an energy storage solution. It is quickly becoming one of the most widely used solar battery banks.

Advantages:

Lithium-ion batteries require almost no regular maintenance.

They also have a higher battery energy density, which means they can hold more power in a smaller space than a lead acid battery.

Lithium-ion batteries also have a longer cycle or life than lithium batteries - most have a guaranteed warranty of at least 15 years. This longer life relates to lithium-ion batteries having a higher depth of discharge, so that you can use more of the energy stored within the battery before recharging it.

Also, due to chemistry, lithium ion storage systems have something called thermal runaway which causes fires and if installed correctly, the chance of a battery catching fire is close to zero.

Best for: Lithium-ion batteries are best for residential solar installations because they can hold more power in a limited space, and allow you to use more of the energy stored inside the battery, which is great for powering a home.

dis advantages:

One of the biggest drawbacks of lithium-ion batteries is that they are more expensive than other energy storage technologies.

Also, if it is not installed properly, it can cause the battery to ignite due to thermal escape.

Battery Type	Flooded lead acid battery	Valve Regulated lead acid battery	Lithium-ion battery
Maintenance	It needs periodic maintenance + ventilation	does not require periodic maintenance	does not require periodic maintenance
discharge depth	less than 80%	reach to 80%	more than 98%
battery life	1000-1500 cycles less than 5 years with daily charge and discharge	1500-2500 cycles 5 -10 years with daily charge and discharge	3000-8000 cycles 15 -25 years with daily charge and discharge
cost	Low	About twice the cost of the first type	4-5 times the cost the first type

b- Factors that help determine the appropriate type of solar battery

What type of solar battery is suitable?

In most cases, the best battery you can get for your home solar installation is a lithium ion battery.

They are able to hold more energy in a small space, dump most of their stored energy, and have high efficiencies. Also, since these are the most common, many solar companies will be able to install a lithium ion solar battery accurately and safely.

If the budget is limited, lead-acid batteries may be the appropriate option in terms of cost, but their life is short and they will need another battery after a period that does not exceed half the life of the lithium battery.

Battery Type	Flooded lead acid battery	Valve Regulated lead acid battery	Lithium-ion battery
Factors that help determine the appropriate battery type	<p>Low cost, the ability to perform regular maintenance.</p> <p>(Desolvation)of the battery every month.</p> <p>Ventilation work for storing batteries.</p>	Batteries bank as a backup source	For an off-grid system planned for a long life, with the need for daily charging and discharging

C-Comparison of the lithium batteries used in our project with the best gel type lead acid batteries common in our country

Battery Type	Valve Regulated lead acid battery of kind (Gel 100Ah , 24v)	Lithium-ion battery of kind (Lifepo4 100Ah , 24V)
Marketing capacity	100 * 24 = 2400Wh	100 * 24 = 2400Wh
The life span	1500-2500 cycles 5 -10 years with daily charge and discharge	4000-8000 cycles 20 -30 years with daily charge and discharge
discharge depth(DOD)	80 %	100%
actual capacity	80Ah *24V =1920Wh	2400Wh
price	1500NIS	2500NIS
price per Wh	0.781NIS	1.04NIS
How many batteries do you need for a system that lasts 20 years	at least two battery	One battery

That is, for a system that lasts 20 years, you need the cost of two gel batteries, as the price of two gel batteries costs 3000 shekels, which is comparable to the price of a lithium battery that costs 2500 shekels.

Chapter 6: Project's Mechanism of work:

part 1: Project location and appropriate design angles for solar panels

- From the global solar atlas website

latitude and longitude : 32.271083°,035.450489°

PVOUT map

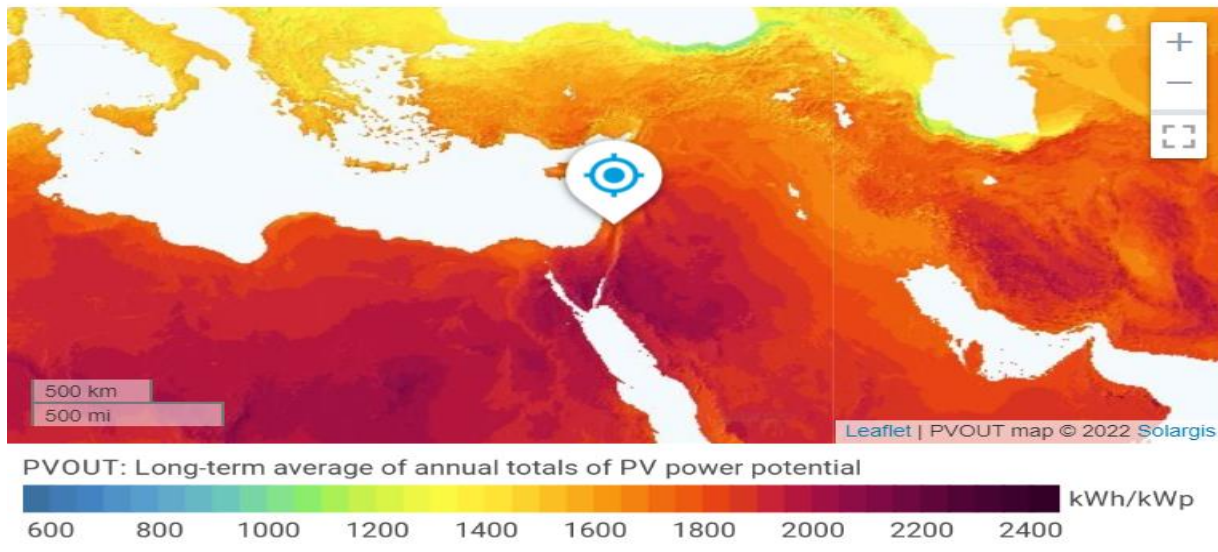

32.271083°,035.450489° ▾
Judea and Samaria, Palestinian Territory
Time zone: UTC+02, Asia/Hebron [EET]



Bookmark



Share



Reports

SITE INFO

Map data

Per day ▾

Direct normal irradiation	DNI	6.036	kWh/m ² per day ▾
Global horizontal irradiation	GHI	5.568	kWh/m ² per day ▾
Diffuse horizontal irradiation	DIF	1.721	kWh/m ² per day ▾
Global tilted irradiation at optimum angle	GTI _{opta}	6.184	kWh/m ² per day ▾
Optimum tilt of PV modules	OPTA	29 / 180	°
Air temperature	TEMP	19.9	°C ▾
Terrain elevation	ELE	103	m ▾

Horizon and sunpath

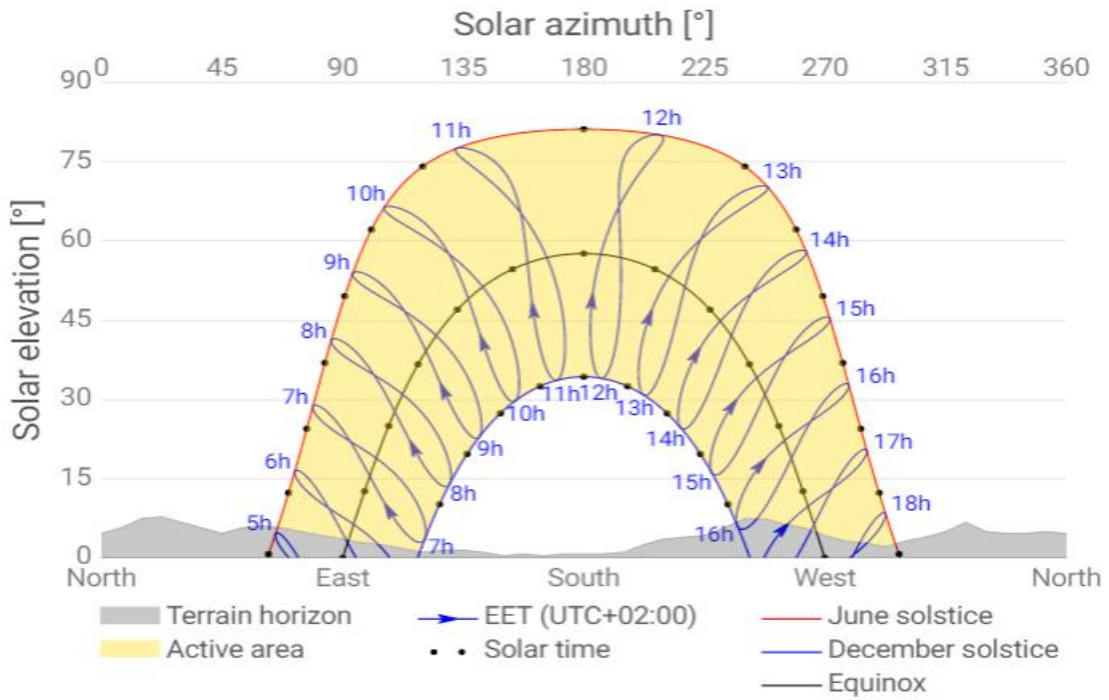

Monthly averages

Total photovoltaic power output

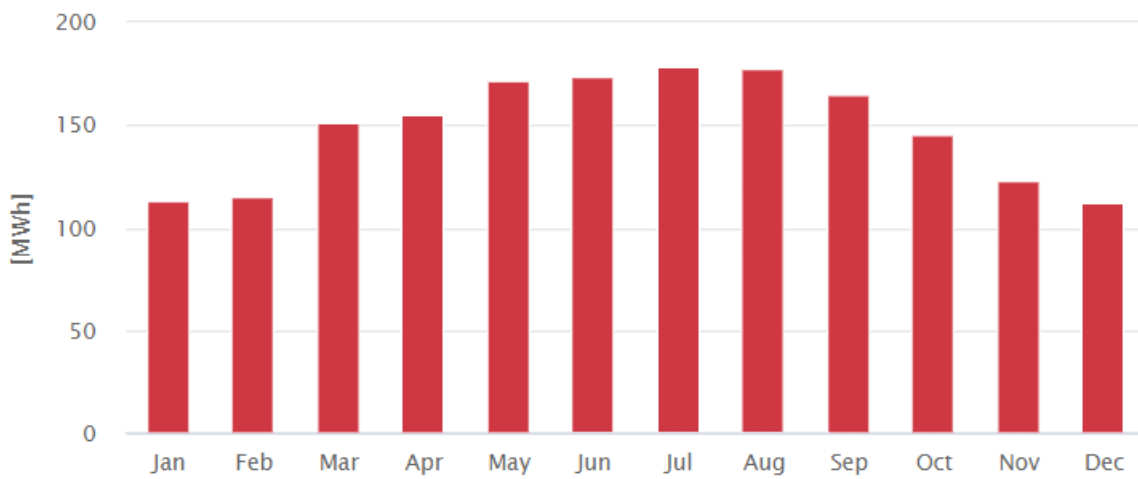

PV system configuration



PV system: **Small residential**
Azimuth of PV panels: **Default** (180°)
Tilt of PV panels: **Default** (29°)
Installed capacity: **1.16 kWp**

[Change PV system](#)

Annual averages

Total photovoltaic power output and Global tilted irradiation

0.005

MWh per day ▾

6.152

kWh/m² per day ▾

Monthly averages

Total photovoltaic power output



Average hourly profiles

Total photovoltaic power output [Wh]



[Show details](#)

UTC+02

Monthly averages

Total photovoltaic power output

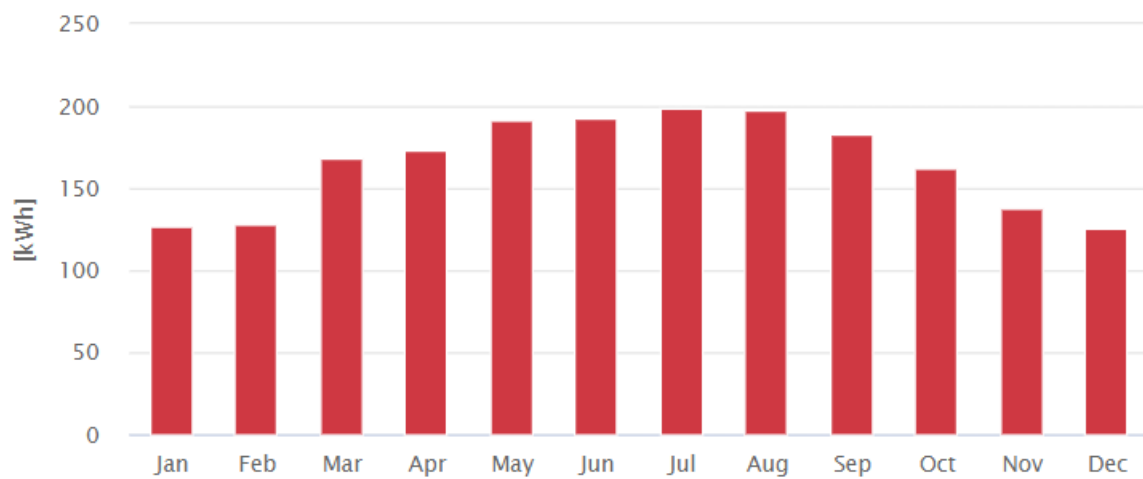

part 2 : Calculation of the electrical energy consumed

Calculate the total consumption for each house :

number	Device type	Power (w)	Quantity (q)	Operating hours during the day(h)	Operating hours at night(h)	The amount of energy required during the day(wh)	The amount of energy required at night(wh)	Total energy during the day and night(wh)	Surge power
1	Neon lighting	18	2	0	8	0	288	288	36
2	Light bulb(LED)	8	3	0	6	0	144	144	24
3	refrigerator	200	1	5	5	1000	1000	2000	600
4	Washing machine	800	1	0.5	0	400	0	400	2400
5	TV	80	1	2	2	160	160	320	80
6	fan	120	1	6	0	720	0	720	120
7	blender	500	1	0.25	0	125	0	125	500
8	laptop	150	1	1	1	150	150	300	150
9	router	20	1	12	12	240	240	480	20
Total		W*q=1930w				2795wh	1982wh	4777wh	3955w

part 3: Calculation of the required solar cell system capacity

We will use Mono crystalline panels from CanadianSolar :

Name panel : Hiku7 Mono PERC (580 W)

Voc=40.5 v Vmp =34.1 v

Isc=18.27 A Imp =17.02 A

We will do the calculations for one house:

Total energy during the day and night(wh)= 4.777 kwh

solar radiation hours= 5.56 kwhp/m²

System efficiency : It is the addition of a percentage to the total depreciation of the loss and it is by (10-30) %, that is, we multiply the total consumption by 130% .

panel capacity = (580 w)

panel energy = (Total energy during the day and night(wh/day) * System efficiency) / (solar radiation hours (kwhp/m²))

panel energy = 4.777 kwh *1.3 / 5.56 = 1116.9w

The number of solar panel = panel energy / panel capacity(w)

The number of solar panel = 1116.9w / (580w) =1.925 ~ 2

Solar System Size = 2 * 580 =1.16kw

The number of solar panels required for the total number of homes = 2 * 12(home) =24 panel

part 4: Calculate the number and capacity of batteries suitable for the system

We will use lithium batteries:

Number of standby days (cloudy: days when there is no electricity production) =1 or 2

We will use the number one .

Depth of Discharge (DOD)= 80 % .

System efficiency : the loss in the process of charging and discharging, as well as in the cables. It is equal to (0.9), but when the system is critical, we multiply by (0.8).

system voltage :12v or 24v or 48v .

The total power of electrical appliances in their number= 1930w .

3000>1930w>1000w If the system is 24 volts .

Battery bank capacity = (energy quantity * Number of standby days)/(DOD * System efficiency * system voltage)

Battery bank capacity = (4777w * 1)/(80% * 0.8 * 24)=311Ah

number of batteries = Battery bank capacity / Single battery capacity

=311 Ah / 100Ah = 3.11 ~ 4

LifePO3 lithium Batteries (four units for each system of 24V\100Ah) to supply daily consumption of 4.77KWH (Total Energy Storage 9.6KWH)

Install and connect four battery units of LifePO3 lithium Batteries

24V\ 100Ah to build battery bank of 24V\400AH.

part 5 : Design the inverters charging control suitable for the system's capacity

OFF Grid Inverter with Built in Solar Charge Controller:

Design and connect an off-grid converter with maximum integrated power point

Solar charge controller (MPPT) and the following specifications:

- inverter capacity = total device capacity * (1-0.3)=1930 *0.7 =1351 ~2kw
Or from system size 1.16 ~2kw
- The voltage of the inverter is 24v because it is the voltage of the battery bank 24v
- Battery bank capacity= 100A
- The maximum charging current of the regulator equal current 20 A
- Surge power = ~4kw
- Frequency= 50 or 60 Hz

charging control :

- Maximum DC operating voltage according to the panel connection. If it is in series, we add the voltage, and if it is parallel, we add the current.
- If the panels are connected in series, then $V_{oc} = 81\text{ v}$ $I_{sc} = 18.27\text{ A}$

Part 6: Implementation of the project by MATLAB software

This is a simple software that lays out the way the components of the system are connected to each other:

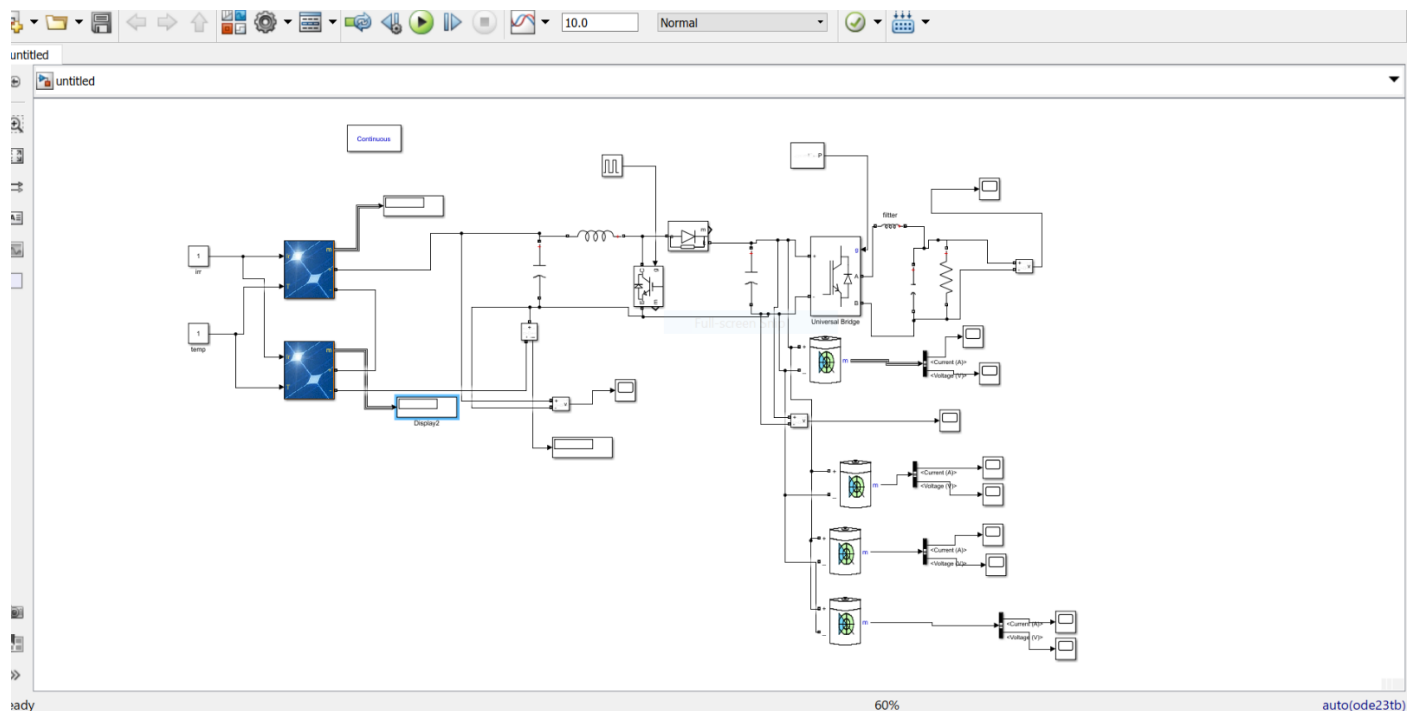

part 7 : Mounting Structure design for each solar system

install hot deep galvanized structure made from 40x40x2mm hot galvanized tube profile with suitable dimensions of the offered PV modules and to maintain an inclination degree 29 degree. The PV modules shall be fitted to the structure using Aluminium rails or hot galvanized tube profile . The galvanized steel base must be fixed to the roof of the house.

Mounting structure must have a certificate from a certified structural for mechanical engineer that the structure peers the load enforced upon it .

part 8: Earthing System design for each solar system:

install and connect Earthing system for each solar unit, which consists of two (16mm² and 1.5M) electrical copper rods (spikes) connected in parallel using inspection manholes. These rods must be buried vertically in the ground, the distance between these rods must be at least 2.5 meters, the rods must be connected together with 16mm² cable, and then the cable must be connected to the main grounding bus bar. All of the installed electrical equipment and the electrical cabinet must be grounded and using all necessary material and accessories to achieve resistivity of less than two Ohm.

part 9: Electricity Cabinet design for each solar system:

install galvanized steel 1.5 mm thickness, thermal painted battery cabinet. This cabinet will be sized to hold batteries, controller, inverter and protection switches. The cabinet consists of two parts, one for battery bank and the other for solar equipment and should have ventilation openings. All cables in the cabinet must be hidden. The battery cabinet must be fixed on galvanized steel base.

Location of the cabinet should be inside the existing structure and must be locked with key to maintain security and safety issues.

The cabinet shall be supplied with AC fan with temperature sensor. Side ventilation openings shall be made to both sides of the cabinet.

part 10 : Main distribution box design for each solar system and home distribution box :

Installing one or two plastic cabinets suitable for each solar unit inside the main electricity cabinet:

- mc4 to connect the wires to each other.
- dc isolator switch to isolate the panels from the inverter

$I(\text{dc isolator}) > I_{sc} = 18.27A$, $I(\text{dc isolator}) = 25A$

$V(\text{dc isolator}) > \text{pv voltage} = 81V$, $V(\text{dc isolator}) > 100$

- 25A DC breaker to protect the DC wires between the panels and the inverter.

$(I_{sc} = 18.27A) * (1.25 \text{ is safety factor}) = 22.83$

$I_{cb} > 22.83A$

$I_{cb} = 25A$

- And the surge protection device, and its abbreviation spd.
- Fuse Anl 110A is used to protect the cable between the battery bank and the inverter because it responds very quickly, so it is preferable to use it instead of a DC breaker.

Fuse capacity = (inverter capacity / battery bank voltage) * 1.25

$= (2000W / 24V) * 1.25 = 83.33 * 1.25 = 104.16 \sim 110A \text{ or } 125A$

- battery disconnect switch to isolate the battery bank from the inverter. 50A DC CB for Battery

$I(\text{disconnect}) > I_{\text{fuse}} = 110A$, $I(\text{disconnect}) = 150A$

V (disconnect) > battery bank voltage =24 , V (disconnect)=32

- busbar of copper for grounding and AC Earth leakage 40A\0.03mA.
- AC main circuit breaker with 16A installed at the inverter output.

$I_L = \text{power} / 230$

$= 2000\text{w} / 230 = 8.69\text{A}$

$I_{cb} > I_L * 1.25 = 10.86\text{A}$

$I_{cb} = 16\text{A}$

part 11 : Calculate the required cable capacity for each system

- 10 mm² cable for earth with suitable length to cover the earth requirements in previous sections
- DC cable of cross section of 35 mm² cable "Black" Battery connection.
- DC cable of cross section of 35 mm² cable "Red" Battery connection.

TYPE PVC

$I_{CABLE} > I_{FUSE} = 110\text{A}$

$I_{CABLE} = 137\text{A}$, area =35mm²

- Solar cable of 4mm² or with suitable capacity as per location of combiner box.

TYPE XLPE

$I_{cable} > I_{cb} = 25\text{A}$

$I_{cable} = 42\text{A}$, area =4mm²

- AC cables of capacity (3x2.5mm²) isolated cable to be installed between outputs of inverter to AC CB in Electricity cabinet.

I_{cable} > I_{cb}=16A

- Using (3/4 inch) or (1 Inch) UV-resistant Conduits for electrical cables between PV modules and the electrical cabinet. (For each solar system) and home distribution box.

part 12 : Economic feasibility of the project

Install 1.16Kwp complete off- grid PV system (the city Tubas , the village of Atuof ,the Actual area).

(Budgetary prices)

No.	the Requirements	Qty for each solar system	Qty for all solar systems	U. P/ NIS for each solar system	Total for all solar systems
1	2 units of PV Modules 580Wp	1	12	1400	16800
2	Off Grid Inverter with built in solar charge controller	1	12	4000	48000
3	4 units of LifePO3 lithium Batteries 24V\100Ah	1	12	10000	120000
4	Hot deep Galvanized Structure	1	12	600	7200
5	Electricity Cabinet	1	12	2300	27600
6	Earth System	1	12	500	6000
7	Accessories for installing the system such DC,AC protection, Slive,,,ect	1	12	300	3600

8	DC and AC cables to install the unit.	1	12	300	3600
9	Main Distribution Board .	1	12	200	2400
10	Installation cost including labor work and cost of any needed materials for installation non mention above .	1	12	200	2400
Total price				19800	237600

Note : The price for each one project for 1.16 kw = 19800 Nis

Note : Consumption of diesel generators:

The cost of diesel generators producing 1 kilo of electricity is equivalent to the price of 2.5 Nis.

- daily consumption= $(4.777w) * (2.5 \text{ Nis}) = 11.9425 \text{ Nis}$
- monthly consumption= daily consumption * (30 days)
 $= 11.9425 * 30 = 358.275 \text{ Nis}$
- Annual consumption= $11.94 * (365 \text{ days}) = 4359 \text{ Nis}$
- Capital recovery period=

$(\text{Total project costs} = 19800 \text{ Nis}) / (\text{cost of daily consumption} = 11.94 \text{ Nis}) = 1658.29$
 $\sim (1659 \text{ days})$

The payback period is 4.54 years

- Also, the project will last for at least 20 years if it is monitored and maintained periodically, as during within 4 and a half years cost of the project will be recovered, and for the rest of the period, homeowners will get free electricity, free of environmental damage and technical problems of generators.

part 13: Implementation of the project by pv syst

We use the program PV-syst to simulate an independent system in the city of Tubas near the Atuf area.

Part I : Autonomous System Status and Steering

We choose a place near al-Ras al-Ahmar, the al-Tuwal area. The appropriate annual inclination angle in Tubas ranges from 27 to 32 degrees.

- We choose the direction

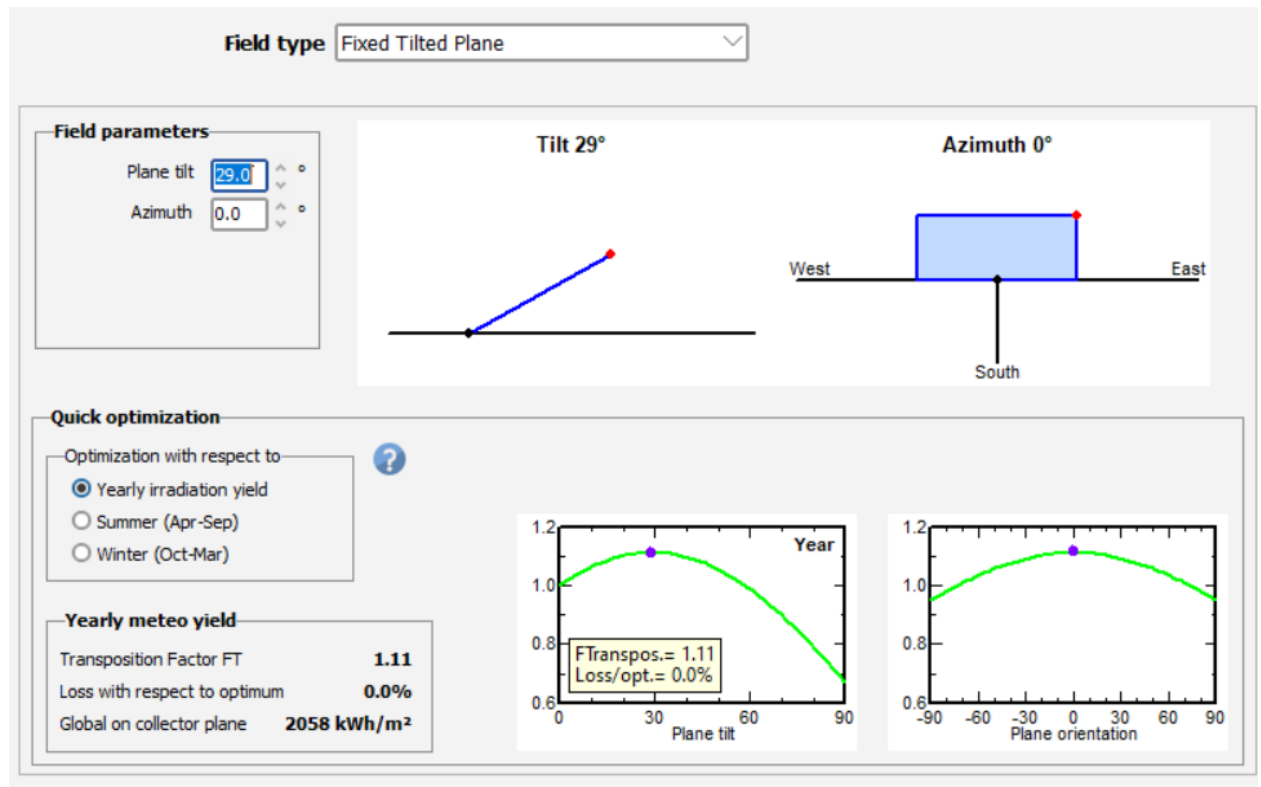

Part 2 : The electrical load of the house

- We choose the following electrical loads for each house:

Definition of daily household consumptions for the year.

Consumption
Hourly distribution

Daily consumptions

Number	Appliance	Power	Daily use	Hourly distrib.	Daily energy
<input type="text" value="2"/>	<input type="text" value="neon lighting"/>	<input type="text" value="18"/> W/lamp	<input type="text" value="8.0"/> h/day	Specify hours	288 Wh
<input type="text" value="3"/>	<input type="text" value="Lamps (LED)"/>	<input type="text" value="8"/> W/app	<input type="text" value="6.0"/> h/day	Specify hours	144 Wh
<input type="text" value="1"/>	<input type="text" value="Washing machine and blender"/>	<input type="text" value="1050"/> W/app	<input type="text" value="0.5"/> h/day	Specify hours	525 Wh
<input type="text" value="1"/>	<input type="text" value="router"/>	<input type="text" value="0.02"/> kWh/day	<input type="text" value="24.0"/>	OK	480 Wh
<input type="text" value="1"/>	<input type="text" value="refrigerator"/>	<input type="text" value="200.0"/> W aver.	<input type="text" value="10.0"/> h/day	Adjust hours	2000 Wh
<input type="text" value="1"/>	<input type="text" value="tv and laptop"/>	<input type="text" value="155"/> W/app	<input type="text" value="4.0"/> h/day	Specify hours	620 Wh
<input type="text" value="1"/>	<input type="text" value="fan"/>	<input type="text" value="120"/> W/app	<input type="text" value="6.0"/> h/day	Specify hours	720 Wh
Stand-by consumers		<input type="text" value="0"/> W tot	<input type="text" value="24"/> h/day		0 Wh
Appliances info ?					
Total daily energy					4777 Wh/day
Monthly energy					143.3 kWh/mth

Consumption definition by

Years ?

Seasons

Months

Week-end or Weekly use

Use only during

days in a week

- We choose the distribution period for the hours in which the loads are used:
The hours distribution period is to determine the working hours of loads per day within 24 hours

Definition of daily household consumptions for the year.

Consumption **Hourly distribution**

neon lighting

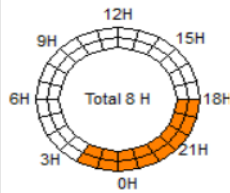

Lamps (LED)

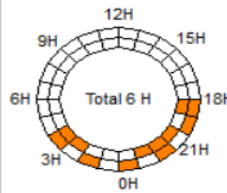

Washing machine and bl

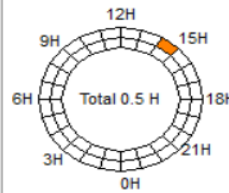

router

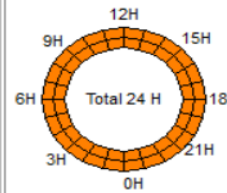

Appliances defined

Show others

refrigerator

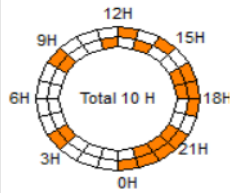

Daily global consumption

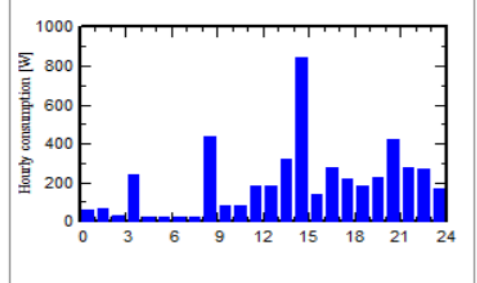

Definition of daily household consumptions for the year.

Consumption **Hourly distribution**

Lamps (LED)

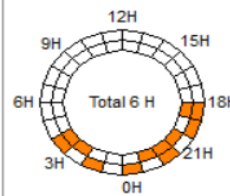

Washing machine and bl

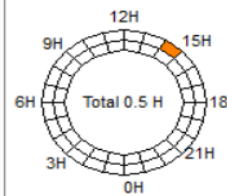

router

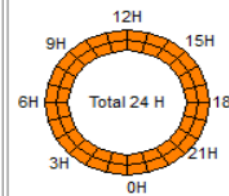

refrigerator

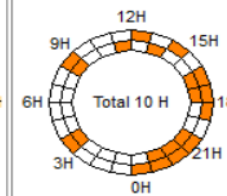

Appliances defined

Show others

tv and laptop

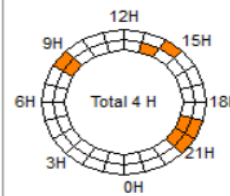

Daily global consumption

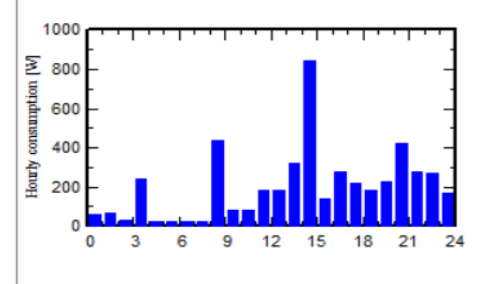

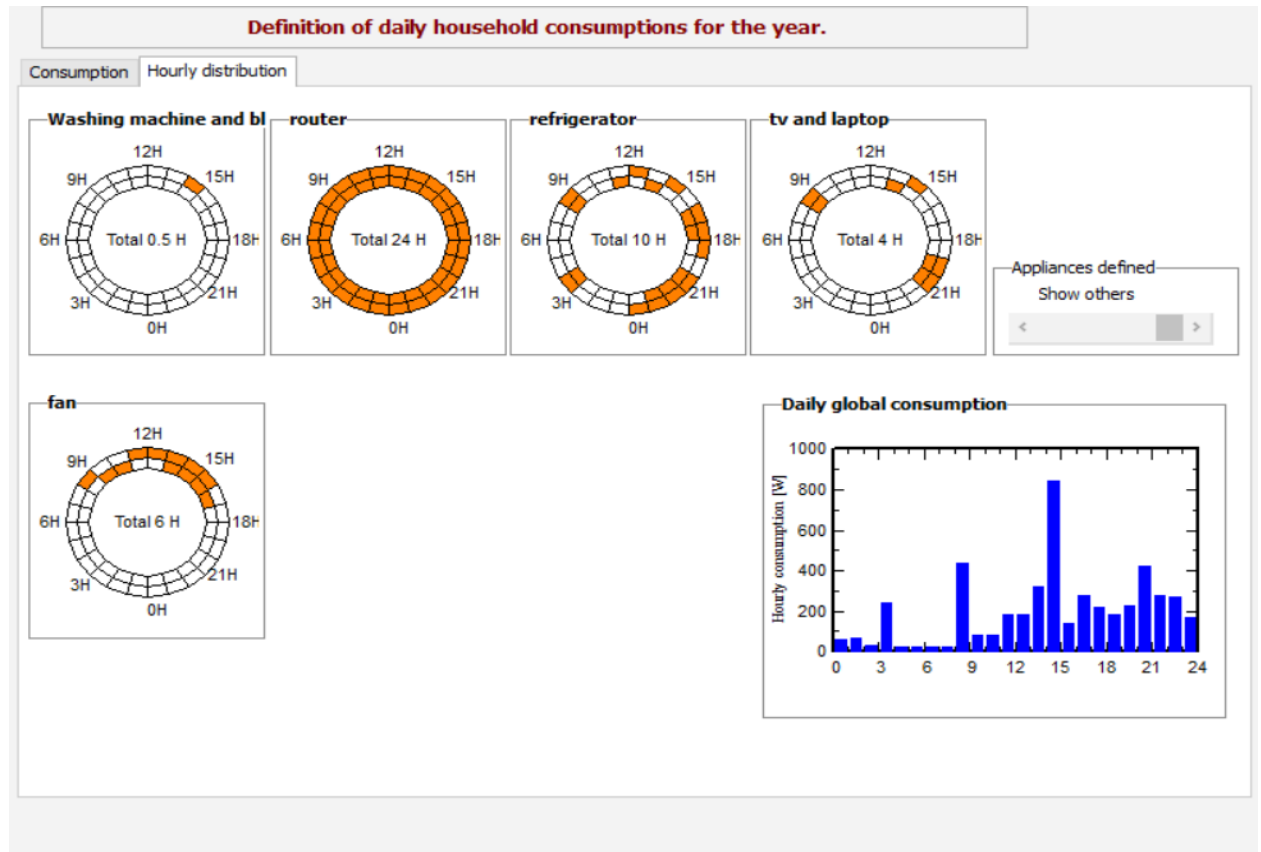

Part 3: PV energy system

- We choose the type and energy of the solar cell

Storage | PV Array | Back-Up | Simplified sketch

Sub-array name and Orientation

Name:

Tilt:

Orient: **Fixed Tilted Plane** Azimuth:

Pre-sizing Help

No sizing

Enter planned power: kWp

... or available area: m²

Select the PV module

All modules

Sort modules: Power Technology

- Determine the phase number of solar cells in series, parallel and area Photovoltaic units

PV Array design

Number of modules and strings		Operating conditions:	
Mod. in series	2 <input type="checkbox"/> should be: between 1 and 2	Vmpp (60°C)	79 V
Nb. strings	1 <input type="checkbox"/> between 1 and 1	Vmpp (20°C)	92 V
Overload loss	0.0%	Voc (-10°C)	120 V
Pnom ratio	0.97	Plane irradiance	1000 W/m ²
Nb. modules	2 Area 6 m ²	Imp (60°C)	12.9 A
		Isc (60°C)	13.7 A
		Isc (at STC)	13.7 A
		Max. operating power (at max. irradi and 50°C)	1.06 kW
		Array nom. Power (STC)	1.16 kWp

- We choose the type and size of the battery, and the program determines the number of batteries needed, and how to connect them in series and parallel, as we choose one day without sunlight, so we need 4 batteries to feed the load for one day without sun

Specify the Battery set

Sort batteries by voltage capacity manufacturer

BYD

Lithium-ion

1 <input type="checkbox"/> cells in series	Number of cells	4	Battery pack voltage	24 V
4 <input type="checkbox"/> cells in parallel	Number of elements	16	Global capacity	400 Ah
100.0 % Initial State of Wear (nb. of cycles)			Stored energy (80% DOD)	8.6 kWh
100.0 % Initial State of Wear (static)			Total weight	136 kg
			Nb. cycles at 80% DOD	7500
			Total stored energy during the battery life	58 MWh

- The average daily need 4.777kwh/day and the battery voltage

Av. daily needs	Enter accepted PLOL	5.0 %	Battery (user) voltage	24 V
4.8 kWh/day	Requested autonomy	2.0 day(s)	Suggested capacity	468 Ah
			Suggested PV power	1397 Wp (nom.)

- The summary of the design

User's needs	Household	Aver. power	199 W
	Night ratio	49.6%	Daily energy
Battery pack	4 in parallel, 24 V	Capacity	400 Ah
	Autonomy	1.8 day	Stored energy
PV Array	1 str. of 2 modules	Nom. Power	1160 Wp
	PV/PLoad	5.8	Av. daily energy
Controller	MPPT converter	Nom. Power	1200 W
	PV/PConv	0.97	Thresholds

- The program displays the design of the independent system

Typical layout of a stand-alone system

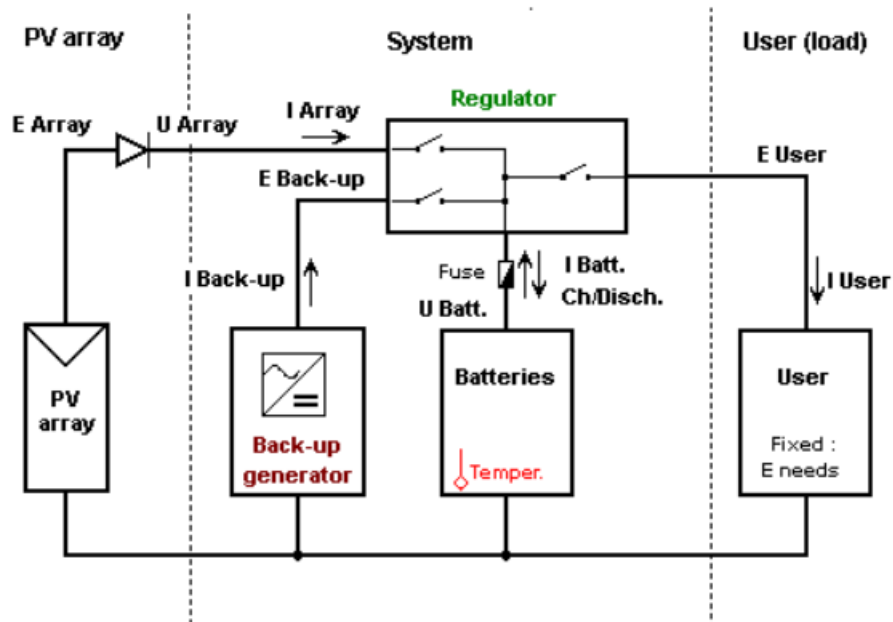

Part 4: The results

- Project specifications for one house

Project summary			
Geographical Site Khirbat 'Aṭūf Palestine, State Of	Situation		
	Latitude	32.27 °N	Project settings Albedo 0.20
	Longitude	35.45 °E	
	Altitude	103 m	
Time zone	UTC+2		
Meteo data Khirbat 'Aṭūf Meteonorm 8.1 (2006-2011), Sat=100% - Synthetic			

System summary			
Standalone system		Standalone system with batteries	
PV Field Orientation Fixed plane Tilt/Azimuth 29 / 0 °		User's needs Daily household consumers Constant over the year Average 4.8 kWh/Day	
System information			
PV Array		Battery pack	
Nb. of modules	2 units	Technology	Lithium-ion, LFP
Pnom total	1160 Wp	Nb. of units	4 units
		Voltage	24 V
		Capacity	400 Ah

- The daily consumptions

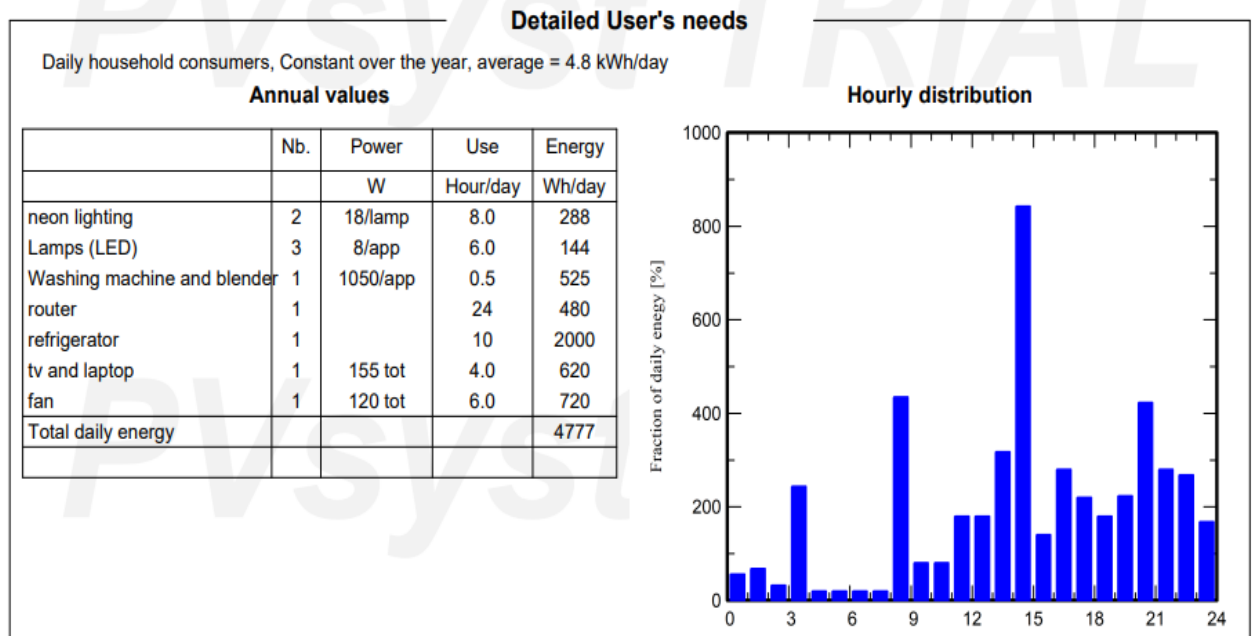

- Main simulation results

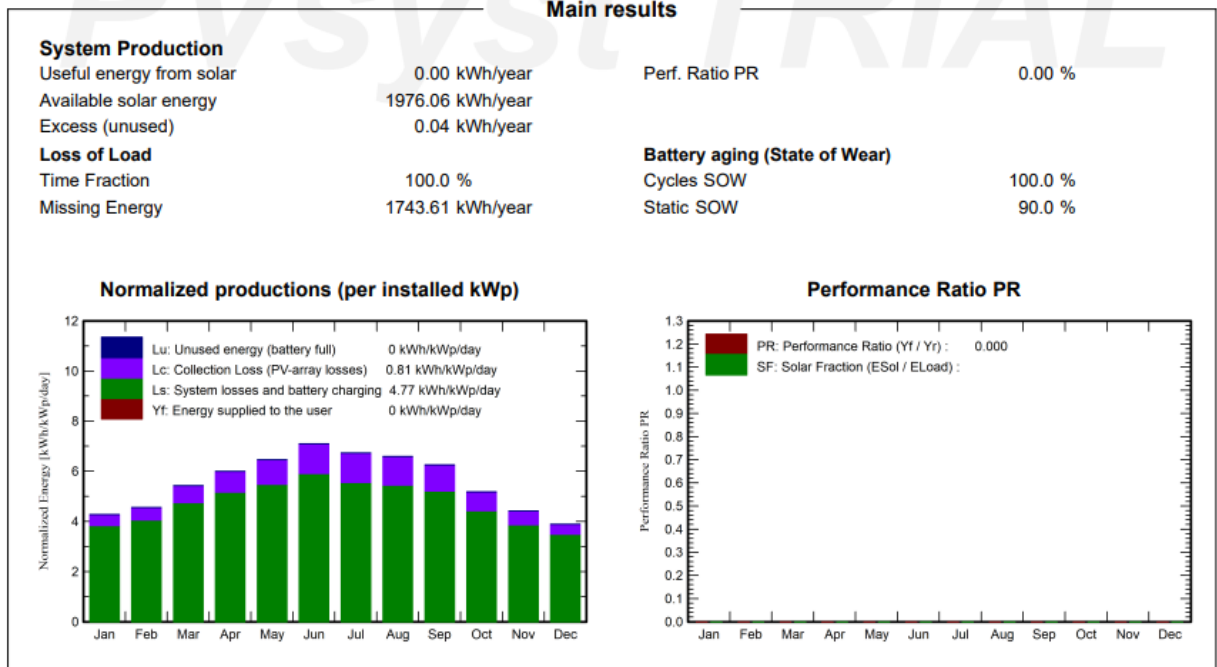

Chapter 7: Project's Mechanism of work for 12 houses together in one network

part 1 : Designing a complete system for all 12 houses, and calculating the devices needed for the system

<u>house number</u>	<u>Total power consumption during the 24 hours</u>	<u>Solar panels energy</u>	<u>Number of panels</u>			<u>Solar System Size</u>
			<u>Capacity 580w</u>	<u>Capacit 590w</u>	<u>Capacity 610w</u>	
<u>12</u>	<u>4.777kwh *12</u> <u>=57324kwh</u>	<u>57.324kwh</u> <u>*1.3 / 5.56</u> <u>= 13.403kw</u>	<u>13.403kw</u> <u>/580 = 23.1</u> <u>~ 24</u>	<u>13.403kw</u> <u>/590 =</u> <u>22.7</u> <u>~ 23</u>	<u>13.403kw</u> <u>/610 =</u> <u>21.97</u> <u>~ 22</u>	<u>22*610w =</u> <u>13.42kw</u>

<u>system voltage</u>	<u>Battery bank capacity = (energy quantity * Number of standby days)/(DOD * System efficiency * system voltage)</u> <u>= (57324kw * 1)/(80% * 0.8 * system voltage)=</u>	<u>number of batteries</u> <u>= Battery bank capacity / Single battery capacity</u> <u>= Battery bank capacity / 100Ah =</u>	<u>number of batteries = Battery bank capacity / Single battery capacity</u> <u>= Battery bank capacity / 200Ah =</u>
<u>24v</u>	<u>3732.03Ah</u>	<u>37.32 ~ 38</u>	<u>18.66 ~ 19</u>
<u>48v</u>	<u>1866.015Ah</u>	<u>18.66 ~ 19</u>	<u>9.33 ~ 10</u>

Inverter design to control charge in proportion to system capacity

OFF Grid Inverter with Built in Solar Charge Controller:

The household load capacity of 12 houses is 23.16 kw.

So we will use a 20kw inverter; because household loads do not work at the same time,

And there is a feature of the inverter that it can accommodate above its capacity a quarter of the basic capacity for a period of time, which means that the 20 kw inverter can operate at a capacity of 25 kw for a short period of time.

The voltage of the inverter is 48v because it is the voltage of the battery bank 48v ,

And Battery bank capacity= 100A .

charging control :

Maximum DC operating voltage according to the panel connection. If it is in series, we add the voltage, and if it is parallel, we add the current.

The panels are connected in two groups in parallel, and each group consists of 11 panels in a row , Panels effort for each group $V_{oc} = 41.7 * 11 \text{panel} = 458.7 \text{ v}$ $I_{sc} = 18.57 \text{ A}$

The total effort of the two groups will be $V_{oc} = 458.7 * 2 = 917.4 \text{ v}$ $I_{sc} = 18.57 * 2 = 37.14 \text{ A}$

part 2: Economic feasibility of a system designed to supply the electricity needs of 12 homes

Install 13.42Kwp complete off- grid PV system (the city Tubas , the village of Atuof ,the Altual area) .

(Budgetary prices)

No.	the Requirements	quantity for the entire solar system	U.P/NIS per unit	Total for all solar system
1	units of PV Modules 610Wp	22	740	16280
2	Off Grid Inverter with built in solar charge controller	1	33000	33000
3	units of LifePO3 lithium Batteries 48V\100Ah	19	5000	95000
4	Hot deep Galvanized Structure	2	2800	5600
5	Electrical cabinet for batteries	2	2500	5000
6	Electrical cabinet for system	2	3000	6000
7	Dispensar meter	1	2000	2000
8	Dispensar meter	1	4000	4000
9	Energy meter to determine the energy needed for each house	12	450	5400
10	Earth System	12	500	6000
11	Main Distribution Board .	12	200	2400
12	Accessories for installing the system such DC,AC protection, Slive,,,ect	1	3000	3000
13	DC and AC cables to install the unit.	1	3000	3000
14	Installation cost including labor work and cost of any needed materials for installation non mention above .	1	1000	1000
	Total price			187680

Note : The cost for all project for 13.42 kw =187680 Nis

Note : The cost per home

The cost of the complete system for 12 houses / the number of 12 houses

$$187680 \text{ Nis} / 12 \text{ houses} = 15640 \text{ Nis}$$

Note : Consumption of diesel generators:

The cost of diesel generators producing 1 kilo of electricity is equivalent to the price of 2.5 Nis.

- daily consumption= (57.324)* (2.5 Nis)= 143.31 Nis
- monthly consumption= daily consumption * (30 days)
=143.31*30=4299.3 Nis
- Annual consumption=(143.31)* (365 days)=52308.15 Nis
- Capital recovery period=

$$\text{(Total project costs=187680 Nis) / (cost of daily consumption 143.31 Nis) = 1309.60} \\ \sim \text{(1310 days)}$$

The payback period is 3.589 years .

Note : Where the cost of the project will be recovered within 3 years and 7 months, and homeowners will get free electricity during the remaining period , free of environmental damage and technical problems of generators.

part 3 : A comparison between installing a system for each home and installing a complete system for all homes

No.	the Requirements	System cost for one house	Total Costs of Solar Power Systems for 12 Homes	Total Cost of Solar Power System Designed for 12 Homes
1	units of PV	1400	16800	16280
2	Off Grid Inverter with built in solar charge controller	4000	48000	33000
3	units of LifePO3 lithium Batteries	10000	120000	95000
4	Hot deep Galvanized Structure	600	7200	5600
5	Electrical cabinet for batteries	----	----	5000
6	Electrical cabinet for system	2300	27600	6000
7	Dispensar meter	---	---	2000
8	Dispensar meter	----	----	4000
9	Energy meter to determine the energy needed for each house	----	----	5400
10	Earth System	500	6000	6000
11	Main Distribution Board .	200	2400	2400
12	Accessories for installing the system such DC,AC protection, Slive,,,ect	300	3600	3000
13	DC and AC cables to install the unit.	300	3600	3000
14	Installation cost including labor work and cost of any needed materials for installation non mention above .	200	2400	1000
	Total price	19800 Nis	237600 Nis	187680 Nis

The final comparison between the cost of designing a system for one house, and the cost of a house from a system designed for 12 houses :

	System cost for one house	The total cost per house of a solar power system designed for 12 homes
cost	19800 Nis	$187680/12=15640$ Nis
Payback period	4.54 years	3.589 years
maintenance costs over the years	lower	higher

So designing a complete system for 12 houses is better than many things, including the costs, as the difference in the total costs of the project for one house is 4160 shekels, and also the recovery period for the project's capital is earlier than designing a system for one house.

Chapter 7 : System component specifications

Part 1: solar panels



HiKu7 Mono PERC

580 W ~ 610 W
CS7L-580 | 585 | 590 | 595 | 600 | 605 | 610MS

MORE POWER

- Module power up to 610 W
Module efficiency up to 21.6 %
- Up to 3.5 % lower LCOE
Up to 5.7 % lower system cost
- Comprehensive LID / LeTID mitigation technology, up to 50% lower degradation
- Better shading tolerance

MORE RELIABLE

- 40 °C lower hot spot temperature, greatly reduce module failure rate
- Minimizes micro-crack impacts
- Heavy snow load up to 5400 Pa, wind load up to 2400 Pa*

Enhanced Product Warranty on Materials and Workmanship*

Linear Power Performance Warranty*

**1st year power degradation no more than 2%
Subsequent annual power degradation no more than 0.55%**

*According to the applicable Canadian Solar Limited Warranty Statement.

MANAGEMENT SYSTEM CERTIFICATES*

ISO 9001:2015 / Quality management system
ISO 14001:2015 / Standards for environmental management system
ISO 45001: 2018 / International standards for occupational health & safety

PRODUCT CERTIFICATES*

IEC 61215 / IEC 61730 / CE / INMETRO / MCS / UKCA
UL 61730 / IEC 61701 / IEC 62716 / IEC 60068-2-68
UNI 9177 Reaction to Fire: Class 1 / Take-e-way



* The specific certificates applicable to different module types and markets will vary, and therefore not all of the certifications listed herein will simultaneously apply to the products you order or use. Please contact your local Canadian Solar sales representative to confirm the specific certificates available for your Product and applicable in the regions in which the products will be used.

CSI Solar Co., Ltd. is committed to providing high quality solar products, solar system solutions and services to customers around the world. Canadian Solar was recognized as the No. 1 module supplier for quality and performance/price ratio in the IHS Module Customer Insight Survey, and is a leading PV project developer and manufacturer of solar modules, with over 55 GW deployed around the world since 2001.

* For detailed information, please refer to the Installation Manual.

CSI Solar Co., Ltd.
199 Lushan Road, SND, Suzhou, Jiangsu, China, 215129, www.csisolar.com, support@csisolar.com

ENGINEERING DRAWING (mm)

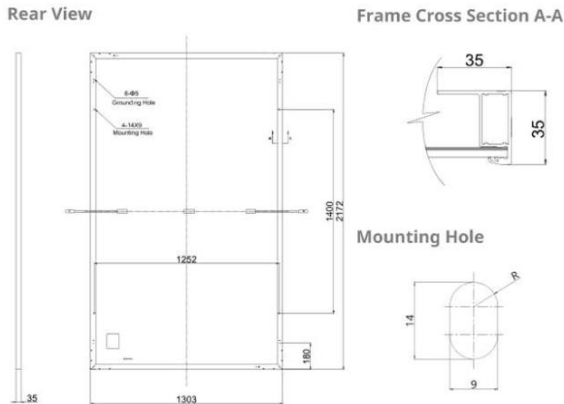

CS7L-590MS / I-V CURVES

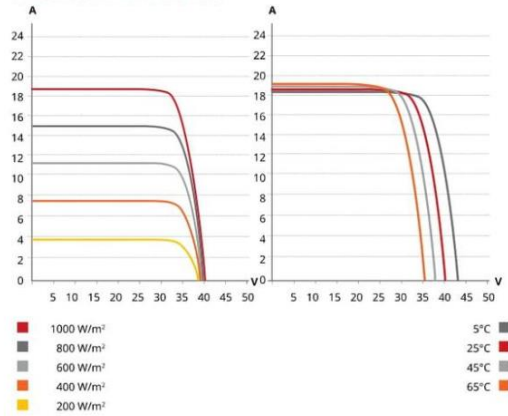

ELECTRICAL DATA | STC*

CS7L	580MS	585MS	590MS	595MS	600MS	605MS	610MS
Nominal Max. Power (Pmax)	580 W	585 W	590 W	595 W	600 W	605 W	610 W
Opt. Operating Voltage (Vmp)	34.1 V	34.3 V	34.5 V	34.7 V	34.9 V	35.1 V	35.3 V
Opt. Operating Current (Imp)	17.02 A	17.06 A	17.11 A	17.15 A	17.20 A	17.25 A	17.29 A
Open Circuit Voltage (Voc)	40.5 V	40.7 V	40.9 V	41.1 V	41.3 V	41.5 V	41.7 V
Short Circuit Current (Isc)	18.27 A	18.32 A	18.37 A	18.42 A	18.47 A	18.52 A	18.57 A
Module Efficiency	20.5%	20.7%	20.8%	21.0%	21.2%	21.4%	21.6%
Operating Temperature	-40°C ~ +85°C						
Max. System Voltage	1500V (IEC/UL) or 1000V (IEC/UL)						
Module Fire Performance	TYPE 1 (UL 61730 1500V) or TYPE 2 (UL 61730 1000V) or CLASS C (IEC 61730)						
Max. Series Fuse Rating	30 A						
Application Classification	Class A						
Power Tolerance	0 ~ + 10 W						

* Under Standard Test Conditions (STC) of irradiance of 1000 W/m², spectrum AM 1.5 and cell temperature of 25°C.

MECHANICAL DATA

Specification	Data
Cell Type	Mono-crystalline
Cell Arrangement	120 [2 x (10 x 6)]
Dimensions	2172 x 1303 x 35 mm (85.5 x 51.3 x 1.38 in)
Weight	31.0 kg (68.3 lbs)
Front Cover	3.2 mm tempered glass
Frame	Anodized aluminium alloy
J-Box	IP68, 3 bypass diodes
Cable	4 mm ² (IEC), 10 AWG (UL)
Connector	T4 series or MC4-EVO2
Cable Length (Including Connector)	460 mm (18.1 in) (+) / 340 mm (13.4 in) (-) (supply additional jumper cable: 2 lines / Pallet) or customized length*
Per Pallet	31 pieces
Per Container (40' HQ)	527 pieces

* For detailed information, please contact your local Canadian Solar sales and technical representatives.

ELECTRICAL DATA | NMOT*

CS7L	580MS	585MS	590MS	595MS	600MS	605MS	610MS
Nominal Max. Power (Pmax)	435 W	439 W	442 W	446 W	450 W	454 W	457 W
Opt. Operating Voltage (Vmp)	32.0 V	32.2 V	32.3 V	32.5 V	32.7 V	32.9 V	33.1 V
Opt. Operating Current (Imp)	13.60 A	13.64 A	13.70 A	13.73 A	13.77 A	13.80 A	13.83 A
Open Circuit Voltage (Voc)	38.3 V	38.5 V	38.7 V	38.8 V	39.0 V	39.2 V	39.4 V
Short Circuit Current (Isc)	14.73 A	14.77 A	14.80 A	14.85 A	14.89 A	14.93 A	14.97 A

* Under Nominal Module Operating Temperature (NMOT), irradiance of 800 W/m²-spectrum AM 1.5, ambient temperature 20°C, wind speed 1 m/s.

TEMPERATURE CHARACTERISTICS

Specification	Data
Temperature Coefficient (Pmax)	-0.34 % / °C
Temperature Coefficient (Voc)	-0.26 % / °C
Temperature Coefficient (Isc)	0.05 % / °C
Nominal Module Operating Temperature	41 ± 3°C

PARTNER SECTION



* The specifications and key features contained in this datasheet may deviate slightly from our actual products due to the on-going innovation and product enhancement. CSI Solar Co., Ltd. reserves the right to make necessary adjustment to the information described herein at any time without further notice. Please be kindly advised that PV modules should be handled and installed by qualified people who have professional skills and please carefully read the safety and installation instructions before using our PV modules.

Part 2: batteries

Ampere Time

LIFE & DISCOVERY

Ampere Time is part of the Li Time Group

- More Powerful R&D Technologies
- Technical and R&D Team with over 19 Years of Industry Experience
- Fully Qualified Assembly Factory Under Strict Control
- Strong and Stable Supply Chain
- The Best Delivery and Customer Service Team

LiFePO4 Batteries
Visit the Store

LiFePO4 Batteries
Visit the Store

Ampere Time LiFePO4 VS Lead Acid Battery

Ampere Time LiFePO4	Lead Acid Battery
Life Time 10 Years	3 Years
Cycles >4000 Times	200-500 Times
Load Power 2560W	600W
Weight 47.4lbs	3 Times the Weight

Ampere Time LiFePO4 battery has 3.2x greater benefits & comprehensive performance than lead acid battery.





24V 100Ah

LITHIUM IRON PHOSPHATE BATTERY

- 100% SOC (State of Charge)
- 100% DOD (Depth of Discharge)
- 4000~8000 times & 10 Yrs Service Life
- IP65 Level Water Proof
- Maintenance Free
- Vibration-Resistance
- Weighting 48 lb (Only 1/3 the Weight of Same Capacity Lead Acid Battery)
- Voltage Hold at Around 25.6V~27.6V (Provide >80% Capacity)

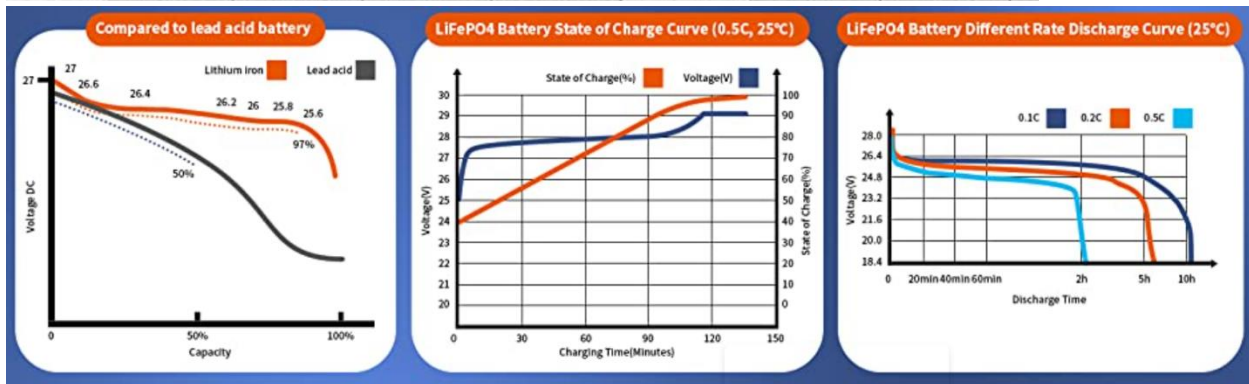

Battery Specifications

Rated Capacity: 100Ah

Nominal Voltage: 25.6V

Voltage Range: 20~29.2V

Maximum Continuous Charging / Discharge Current: 100A

Maximum Permanent Discharging Current: 280A 5Sec.

Dimensions: L20.5*W9.37*H8.54inch

Weight: Approx. 47.4lb / 21.5kg

Terminal Type: M8

Operating Temperature: Charge: 0°C to 50°C;

Discharge: -20°C to 60°C



- Providing 4000~8000 cycles, 10 times longer than lead acid battery with only 200~500 cycles



12V 50Ah PLUS 12V 100Ah 12V 200Ah 12V 200Ah PLUS 12V 300Ah 24V 100Ah

Nominal Voltage	12.8V	12.8V	12.8V	12.8V	12.8V	25.6V
Charge Voltage	14.6V	14.6V	14.6V	14.6V	14.6V	29.2V
Energy	640Wh	1280Wh	2560Wh	2560Wh	3840Wh	2560Wh
BMS Board	50A	100A	100A	200A	200A	100A
Maximum Continuous Charging / Discharge Current	50A	100A	100A	200A	200A	100A
Weight	14.3lb / 6.5kg	25.35 lbs / 11.5kg	46.07 lbs / 20.9kg	52.25lb / 23.7kg	62.83lb / 28.5kg	47.4lb / 21.5kg
Dimension	L7.79*W6.53*H6.6 9inch	L13*W6.82*H8.48 inch	L20.5*W9.37*H8.5 4inch	L20.5*W9.37*H8.5 4inch	L20.5*W9.37*H8.5 4inch	L20.5*W9.37*H8.54 inch
Max. Load / Inverter Power	640W	1280W	1280W	2560W	2560W	2560W
Recommend Solar Panel Configuration (Fully charges with effective sunshine 4.5h/day)day)	150W	300W	600W	600W	900W	600W
Wire(s) for Series & Parallel Connection / Loading	10 AWG	6 AWG	6 AWG	2* 6 AWG	2* 6 AWG	6 AWG

Part 3: inverters

1- the first part :

Inverter specifications for one house:

- Pure Sine wave solar inverter
- Power factor is 1
- LCD display indicates the voltage, Ampere and charging\ discharging status
- DC Input voltage 24 volts.
- Output voltage 230 VAC.
- Output frequency 50 Hz.
- Rated power is 2000VA.
- Overload and short circuit protection.
- Surge power of at least 4000 VA.
- Inverter efficiency minimum 96%.

- Suitable to use with refrigerators and motors.
- Certifications: UL, CE, IEC or equivalents.
- The inverter must have a minimum of (15years) warranty.
- The inverter should be made in Europe or USA .

Built in Solar Charge Controller Specifications:

- DC Voltage 81volt. Which is between range 50v -200v
- Rated current 18.27 A. Which is 20A max current
- Optional Data logger.
- Current and voltage ratings must be compatible with the PV array mentioned before.
- LCD display (volt, Ampere, and charging status).
- Certifications CE, or equivalent.
- The controller must have a minimum of (15 years) warranty.
- The Charge Controller should be made in Europe or USA.

2- The second part :

Inverter specifications for 12 houses together in one network

- Pure Sine wave solar inverter
- Power factor is 1
- LCD display indicates the voltage, Ampere and charging\ discharging status
- DC Input voltage 48 volts.
- Output voltage 400VAC.
- Output frequency 50 Hz.
- Rated power is 20kVA.
- Overload and short circuit protection.
- Surge power of at least 40k VA.
- Inverter efficiency minimum 96%.
- Suitable to use with refrigerators and motors.
- Certifications: UL, CE, IEC or equivalents.
- The inverter must have a minimum of (15years) warranty.
- The inverter should be made in Europe or USA .

Built in Solar Charge Controller Specifications:

- DC Voltage 917.4 volt. Which is between range 800v -1200v
- Rated current 37.14A. Which is 40 A max current
- Optional Data logger.
- Current and voltage ratings must be compatible with the PV array mentioned before.
- LCD display (volt, Ampere, and charging status).
- Certifications CE, or equivalent.
- The controller must have a minimum of (15 years) warranty.
- The Charge Controller should be made in Europe or USA.

Chapter 8 : Conclusion , References .

conclusion :

- Using the off-grid solar energy system, we were able to build a complete system for generating electricity in our approved area (Atouf village) consisting of 12 houses. Depending on the solar radiation, and this is the advantage of this system, it works under all conditions, day or night, summer or winter. There are standards that have been adopted in our calculations that are suitable for all conditions.. The method used to install the system has also been clarified, and the components of the system have been clarified, which are represented by 1) panels, their types, and a method Its approved connection to our project . 2) inverter type and related calculations .3) Battery, its type and number, and how it is connected to the system.
- We conducted several calculations showing the daily consumption of each house, and the result for the night and day periods was that the consumption of the house was equivalent to 4.777 kwh. Based on this number and the radiation rate of 5.56 kw/hp/m², we calculated the number of solar panels for each house. We made several calculations showing the daily consumption of each house, and the result for the night and day periods was that the house's consumption was equivalent to 4.777 kWh. Based on this number and the radiation rate of 5.56 kWh/m², we calculated the number of solar panels per house.
But if we come to the batteries, we used lithium batteries, and we explained the reasons for the choice ... We also made the calculations for their required number,

depending on the information we studied in the previous courses, and then we made the necessary calculations for the appropriate cable and circuit breakers and fuses.

- We conducted a complete feasibility study for the two systems:
The first is a system designed for one house, and the second is a system designed for 12 houses together.
Comparing the results of the two systems with the results of consuming diesel transformers currently used in villages, and then comparing the two systems with each other in terms of the aspects of preference for either of them.
Where the cost of the first system designed for one house was 19800 shekels, and the cost of one house was 15640 shekels of the second system designed for 12 houses together, and through calculations we concluded that the recovery period for the two systems was 4 and a half years for the first system and 3 years and 7 months for the second system..
- So designing a complete system for 12 houses is better than many things, including the costs, as the difference in the total costs of the project for one house is 4160 shekels, and also the recovery period for the project's capital is earlier than designing a system for one house.
Where the cost of the project will be recovered within 3 years and 7 months, and homeowners will get free electricity during the remaining period , free of environmental damage and technical problems of generators.
- By adopting the system, it is valid for at least 15-20 years.
Through these results, we were able to prove the benefit of this system to the people of the village .

References:

1-Massader Company

(www.massader.ps)

2-Hybrid Company for Solar Energy and Electrical Works

(<https://www.facebook.com/hybrid.ps.energy?mibextid=LQQJ4d>)

3-Yaseen Solar Company

(<https://m.facebook.com/Yaseen.Mechanics/?mibextid=LQQJ4d>)

4-Solar Solutions Company

(<https://www.facebook.com/profile.php?id=100076100296230&mibextid=LQQJ4d>)

5-Al-Akhras Company

(<https://www.facebook.com/ALLESCOco/?mibextid=LQQJ4d>)

6- Al-Carmel Energy Solutions

(<https://www.facebook.com/carmelenergysolutions/?mibextid=LQQJ4d>)

7- books :

Book Off Grid Solar Power Simplified By Will Smart

Book Electrical installations and designs book by Mahmoud Gilani

8- canadiansolar.com & jinkosolar.com

<http://www.electronicshub.org/lead-acid-battery-charger-circuit/>

http://www.progressivedyn.com/battery_basics.htm

-<https://academic.oup.com/ce/article/3/1/47/5308048>

<https://books-library.online/free-8020417-download> }